



Indian and Northern
Affairs Canada

Affaires indiennes
et du Nord Canada

DEPARTMENT OF INDIAN AFFAIRS
AND NORTHERN DEVELOPMENT

**DESIGN GUIDELINES
FOR WASTEWATER SYSTEMS
BRITISH COLUMBIA REGION
THIRD EDITION**

NOVEMBER, 2008

A vertical decorative bar on the right side of the cover, composed of several overlapping, semi-transparent, curved shapes in various shades of blue and white. At the bottom of this bar, there is a small rectangular section with a red background and a yellow curved shape.

Canada 

**Design Guidelines
for Wastewater Systems
British Columbia Region
Third Edition**

Published under the authority of the
Minister of Indian Affairs and Northern
Development and Federal Interlocutor for
Métis and Non-Status Indians
Ottawa, 2008
www.ainc-inac.gc.ca
1-800-567-9604
TTY only 1-866-553-0554

QS-B047-000-EE-A1
Catalogue No.R3-87/2008E-PDF
ISBN 978-1-100-11524-5

© *Minister of Public Works and Government
Services Canada*

ACKNOWLEDGEMENTS

The 1987 edition of the Guidelines was prepared by:

- Greg Bull, P.Eng., Department of Indian and Northern Affairs Canada, BC Region
- D. L. S. Ellis, P.Eng., Environment Canada, Pacific Region
- J. S. Wishart, P.Eng., Health Canada, Pacific Region.

The 1991 Draft edition was prepared by:

- Phil Wong, M. A.Sc., P.Eng., Public Works Canada, DIAND Technical Services, Pacific Region
- Rob Radloff, P.Eng. Public Works Canada, DIAND Technical Services, Pacific Region.

The 2008 edition was prepared by a technical committee consisted of the following members:

- Jian (Jane) Guo, B.Eng., M.A.Sc., P.Eng., Department of Indian and Northern Affairs Canada, BC Region
- Dr. Allan Gibb, P.Eng., Dayton and Knight Ltd., Consulting Engineers
- Roger Warren, M.Eng., P.Eng., Dayton & Knight Ltd., Consulting Engineers
- Dr. O. (Sam) Turk, P.Eng., NovaTec Consultants Inc.

Preparation of these Guidelines would not have been possible without the outstanding collective contributions of the above people. We also owe special thanks to Mr. Gerry Grunau, P.Eng., Manager of Community and Infrastructure Services of INAC for providing direction and technical support on the revision of these guidelines. We also like to thank Health Canada, Environment Canada, and the Province of British Columbia Ministry of Environment for providing regulatory information.

The sources for part of these guidelines adopted herein, include the B.C. Municipal Sewage Regulation, (1999); the B.C. Sewerage System Regulation (2005); and Environment Canada's Proposed Regulatory Framework for Wastewater and the CCME Draft Canada Wide Strategy for the Management of Municipal Wastewater Effluent, September, 2007.

Gary Gee, P.Eng.,
Director, Professional and Technical Services
INAC, BC Region

INSTRUCTIONS FOR USE OF THESE GUIDELINES

These guidelines are intended to serve as a guide in the design and preparation of plans and specifications for domestic wastewater systems for First Nations Communities in British Columbia Region. These guidelines suggest limiting values for items by which the plans and specifications can be evaluated, and by which, as far as practicable, uniformity of practice can be established. These guidelines are intended to complement and enhance applicable Federal and Provincial legislation, standards and guidelines.

The terms "shall" and "must" are used where practice is sufficiently standardized to permit specific delineation of requirements or where safeguarding of the public health justifies such definite action. Other terms, such as "should", "recommended", and "preferred", indicate desirable procedures or methods, with deviations subject to individual consideration.

These guidelines are intended to be used by individuals who, by virtue of their education, training, and experience, are qualified to exercise the professional judgment necessary to select and design wastewater facilities. All collective, individual non-residential and complex individual residential wastewater systems shall be investigated and designed by a Qualified Professional who is certified by the Association of Professional Engineers and Geoscientists of BC and specialized in the wastewater discipline. Simple single residential septic tank ground disposal systems may be designed by a Registered Onsite Wastewater Practitioner who is registered by the Applied Science Technologists and Technicians of BC and has training through the West Coast Onsite Wastewater Training Centre.

The latest version of INAC's Practical Guide for Capital Projects shall be followed for development of capital projects for First Nations. Any conflict between these two guidelines shall be brought to the attention of the INAC Wastewater Engineer prior to proceeding.

Users shall be cognizant of the existing and any future updates of applicable Federal and Provincial legislations, standards and guidelines, including the Federal standards for municipal wastewater discharges developed by the Canadian Council of Ministers of the Environment (CCME).

These guidelines apply to the design of the following First Nations wastewater systems in B.C.:

- Individual systems designed to serve residents with less than five house connections or non-residential facilities with a design flow of less than 9,100 L/d; and
- Collective systems serving five or more house connections or non-residential facilities with design flows of 9,100 L/d and greater.

The Policy Statements described on the following pages apply to the design of wastewater systems for First Nations Communities in British Columbia Region. It is essential that users of these guidelines carefully review the Policy Statements prior to initiating the preparation of project submissions and design of the systems.

DESIGN GUIDELINES FOR WASTEWATER SYSTEMS IN B.C. REGION

TABLE OF CONTENTS

	<u>PAGE</u>
ACKNOWLEDGEMENTS	i
INSTRUCTIONS FOR THE USE OF THESE GUIDELINES	ii
TABLE OF CONTENTS	iii
POLICY STATEMENTS	xiii
Policy Statement #1: Health and Safety	P-1
Policy Statement #2: Developing Options for Wastewater Collection, Treatment and Disposal or Reuse.....	P-2
Policy Statement #3: Discharges to Ground Disposal Systems.....	P-3
Policy Statement #4: Effluent Quality for Discharges to Surface Waters	P-4
Policy Statement #5: Monitoring Frequency for Discharges to Surface Water and to Ground Disposal Systems.....	P-5
Policy Statement #6: Registering Discharges under the British Columbia Municipal Sewage Regulation	P-6
Policy Statement #7: Wastewater Overflows and Bypasses	P-7a
Policy Statement #8: Management of Wastewater Sludge and Biosolids.....	P-8
Policy Statement #9: General.....	P-9

PART 1 – PROJECT SUBMISSIONS

1.1 GENERAL	1-1
1.1.1 Document Submissions	1-1
1.1.2 Design Period	1-2
1.1.3 Option Analyses	1-2
1.1.4 Operation and Maintenance Documents.....	1-2
1.1.5 Units.....	1-2
1.1.6 Compliance with INAC and Regulatory Requirements.....	1-2
1.1.7 Sustainability	1-3
1.2 FEASIBILITY REPORT	1-3
1.2.1 Title	1-5
1.2.2 Title Page.....	1-5
1.2.3 Table of Contents	1-5
1.2.4 Summary	1-5
1.2.5 Introduction.....	1-5
1.2.6 Existing Wastewater Facilities	1-5

1.2.7	Land Use and Development	1-6
1.2.8	Regulatory and Environmental Issues.....	1-6
1.2.9	Concept Alternatives for Wastewater System	1-6
1.2.10	Analysis of Alternatives	1-7
1.2.11	Environmental Assessment Scoping Report.....	1-7
1.2.12	Regulatory Issues.....	1-7
1.2.13	Land Encumbrance Check	1-7
1.2.14	Timber Permit Assessment	1-7
1.2.15	Conclusions and Recommendations	1-8
1.3	PRE-DESIGN REPORT	1-8
1.3.1	Title	1-9
1.3.2	Title Page.....	1-9
1.3.3	Table of Contents	1-9
1.3.4	Summary	1-9
1.3.5	Introduction	1-9
1.3.6	Existing Conditions and Projections	1-9
1.3.7	Existing Facilities Evaluation (with appropriate drawings).....	1-11
1.3.8	Proposed Project Development.....	1-11
1.3.9	Appendices: Technical Information and Design Criteria	1-14
1.4	DESIGN REPORT	1-16
1.4.1	General.....	1-16
1.4.2	Collection.....	1-16
1.4.3	Treatment	1-17
1.4.4	Disposal/Reuse	1-17
1.4.5	Cost Estimates	1-17
1.4.6	Draft Operation and Maintenance Documents.....	1-17
1.4.7	Facility Classification and Operator Training Plan.....	1-17
1.4.8	Commissioning Plan.....	1-18
1.4.9	Performance Monitoring Plan.....	1-18
1.4.10	Environmental Assessment Study Report.....	1-18
1.5	DETAILED DESIGN DRAWINGS.....	1-18
1.5.1	General.....	1-18
1.5.2	Location Plan.....	1-19
1.5.3	General Layout Drawings	1-19
1.5.4	Detailed Drawings	1-20
1.6	SPECIFICATIONS.....	1-22
1.7	REVISIONS TO PLANS	1-22
1.8	ADDITIONAL INFORMATION	1-22

1.9	OPERATION AND MAINTENANCE INFORMATION AND CONSIDERATIONS	1-23
1.9.1	Scope.....	1-23
1.9.2	Operation and Maintenance Manual	1-23
1.9.3	Operation and Maintenance Plan	1-27
1.9.4	Emergency Response Plan	1-29

PART 2 – SEWERS

2.1	DESIGN CAPACITY.....	2-1
2.1.1	Average Dry Weather Per Capita Flow (a).....	2-1
2.1.2	Peaking Factor (f)	2-1
2.1.3	Peak Wet Weather Infiltration and Inflow (I).....	2-2
2.1.4	Peak Institutional, Commercial and Industrial Flow (C).....	2-2
2.2	COMBINED SEWERS.....	2-4
2.3	DETAILS OF DESIGN AND CONSTRUCTION.....	2-4
2.3.1	Minimum Size	2-4
2.3.2	Slope.....	2-5
2.3.3	Alignment.....	2-6
2.3.4	Changes in Pipe Size	2-6
2.3.5	Materials	2-6
2.3.6	Trenching, Bedding and Installation	2-8
2.3.7	Joints, Infiltration and Leakage.....	2-9
2.4	MANHOLES	2-9
2.4.1	Location	2-9
2.4.2	Drop Type.....	2-10
2.4.3	Flow Channel.....	2-12
2.4.4	Diameter	2-12
2.4.5	Manhole Stubs.....	2-12
2.4.6	Watertightness.....	2-12
2.4.7	Prevention of Gravel and Grit Ingress	2-12
2.5	INVERTED SIPHONS	2-13
2.6	SEWERS CROSSING OR ADJACENT TO STREAMS	2-13
2.6.1	Location of Sewers on Streams.....	2-13
2.6.2	Construction	2-14
2.7	AERIAL CROSSINGS.....	2-15

2.8	PROTECTION OF WATER SUPPLIES	2-15
2.8.1	Water Supply Interconnections.....	2-15
2.8.2	Relation to Water Works Structure	2-15
2.8.3	Separation of Watermains, Sanitary Sewers, and Storm Sewers.....	2-15
2.9	SERVICE CONNECTIONS	2-16
2.9.1	Definitions	2-16

PART 3 – WASTEWATER PUMPING STATIONS

3.1	INTRODUCTION	3-1
3.2	LOCATION AND LAYOUT	3-3
3.2.1	Service Area	3-3
3.2.2	Gravity Flow.....	3-3
3.2.3	Excavation	3-3
3.2.4	Aesthetics	3-3
3.2.5	Dewatering.....	3-3
3.2.6	Flood Elevations	3-3
3.2.7	Access	3-4
3.2.8	Security.....	3-4
3.2.9	Utilities	3-4
3.2.10	Site Power	3-4
3.2.11	Standby Power	3-4
3.2.12	Soil Investigations.....	3-4
3.2.13	Features.....	3-4
3.2.14	Safety.....	3-4
3.2.15	Costs.....	3-5
3.3	INFLUENT STRUCTURES AND FORCEMAIN.....	3-5
3.3.1	Influent Pipe.....	3-5
3.3.2	Influent Manhole	3-5
3.3.3	Influent Velocity	3-5
3.3.4	Air Entrapment.....	3-5
3.3.5	Flow Patterns.....	3-5
3.3.6	Debris Management	3-5
3.3.7	Valves	3-6
3.3.8	Couplings.....	3-6
3.3.9	Forcemains	3-6
3.3.10	Alarms.....	3-6

3.4	SUBMERSIBLE PUMPS AND STATIONS.....	3-6
3.4.1	General.....	3-8
3.4.2	Pumps.....	3-9
3.4.3	Wet Wells.....	3-10
3.4.4	Pipes and Valves.....	3-12
3.4.5	Lifting Device.....	3-12
3.5	METHODS OF OVERFLOW PREVENTION	3-14
3.5.1	Storage.....	3-14
3.5.2	Infiltration Basin.....	3-14
3.5.3	Standby Pump.....	3-14
3.5.4	Engine Driven Generators.....	3-14
3.6	ELECTRICAL DESIGN	3-15
3.6.1	Equipment.....	3-15
3.6.2	Design.....	3-15
3.6.3	Wiring.....	3-15
3.6.4	Kiosk.....	3-15
3.6.5	Ventilation.....	3-18
3.6.6	Lighting.....	3-18
3.6.7	Circuit Breakers.....	3-19
3.6.8	Nameplates.....	3-19
3.6.9	Transformers.....	3-19
3.6.10	Level Regulators and Controls.....	3-19
3.6.11	Junction Boxes.....	3-19
3.6.12	Power Quality Monitors.....	3-20
3.7	HEATING AND VENTILATING.....	3-20
3.7.1	Air Supply Fan.....	3-20
3.7.2	Exhaust Vent.....	3-20
3.7.3	Heating.....	3-20
3.7.4	Insulation.....	3-20
3.7.5	Kiosk.....	3-20
3.8	INSTRUMENTATION AND CONTROLS.....	3-21
3.8.1	Level Controls.....	3-21
3.8.2	Programmable Logic Controller (PLC).....	3-21
3.8.3	Hour Meters.....	3-21
3.8.4	Alarms.....	3-21
3.8.5	Surge Control.....	3-22
3.8.6	Engine Driven Generators.....	3-22
3.8.7	Flow Measurement.....	3-22
3.8.8	Power Surge Protection.....	3-22
3.9	OPERATION INSTRUCTIONS, SPECIAL TOOLS AND SPARE PARTS.....	3-22

3.10	FORCEMAINS	3-22
3.10.1	Velocity	3-22
3.10.2	Air Relief and Combination Air-Vacuum Relief Valves.....	3-22
3.10.3	Termination.....	3-23
3.10.4	Design Pressure	3-23
3.10.5	Swabbing.....	3-23
3.10.6	Special Construction.....	3-23
3.10.7	Design Friction Losses	3-23
3.10.8	System Curves	3-23
3.10.9	Separation From Watermains.....	3-24
3.10.10	Identification	3-24

PART 4 – WASTEWATER TREATMENT

4.1	GENERAL	4-1
4.1.1	Effluent Quality Requirement.....	4-1
4.1.2	Effluent Reclamation and Reuse	4-1
4.1.3	Advanced Treatment	4-1
4.1.4	Disinfection	4-1
4.1.5	Equipment and Process Reliability	4-2
4.2	DESIGN FLOWS AND LOADS	4-2
4.2.1	Hydraulic Design	4-2
4.2.2	Treatment Process Design	4-2
4.3	SEPTIC TANKS	4-3
4.3.1	Influent.....	4-3
4.3.2	Location	4-3
4.3.3	Typical configuration.....	4-3
4.3.4	Materials and Construction.....	4-4
4.3.5	Tank Capacity.....	4-5
4.3.6	Tank Dimensions and Liquid Depth	4-5
4.3.7	Inlets	4-5
4.3.8	Outlets	4-5
4.3.9	Effluent Filter	4-6
4.3.10	Scum Storage and Venting.....	4-6
4.3.11	Multiple Compartments.....	4-6
4.3.12	Access and Inspection.....	4-6
4.3.13	Collective Septic Tanks	4-7
4.3.14	Twinning	4-7
4.3.15	Maintenance	4-7
4.3.16	Septage Treatment.....	4-8

4.4	FACULTATIVE STABILIZATION LAGOONS	4-9
4.4.1	General Requirements	4-10
4.4.2	Anaerobic Cells	4-11
4.4.3	Facultative Cells	4-11
4.4.4	Facultative Storage Cell(s)	4-12
4.4.5	Controlled Seasonal Discharge	4-12
4.5	PARTIAL MIX AERATED LAGOON SYSTEMS	4-13
4.5.1	General Requirements	4-14
4.5.2	Number of Cells	4-14
4.5.3	Sizing of Treatment Cells	4-14
4.5.4	Design Depth	4-15
4.5.5	Polishing Cell	4-16
4.5.6	Aeration Requirement.....	4-16
4.5.7	Diffused Air System	4-18
4.5.8	Mechanical Aeration	4-19
4.6	DESIGN CONSIDERATION FOR LAGOON SYSTEMS	4-20
4.6.1	Seepage	4-20
4.6.2	Water Mass Balance	4-20
4.6.3	Setback Distances	4-21
4.6.4	Physical Site Constraints.....	4-21
4.6.5	Prevailing Winds	4-21
4.6.6	Geotechnical Information.....	4-22
4.6.7	Hydrogeology	4-22
4.6.8	Groundwater Monitoring	4-22
4.6.9	Surface Run-off Diversion	4-23
4.6.10	Natural In Situ Liners	4-23
4.6.11	Compacted Clay Liners	4-23
4.6.12	Bentonite and Sand Admix Liners	4-24
4.6.13	Asphalt Liners	4-24
4.6.14	Flexible Polymeric Membrane Liners	4-24
4.6.15	Access	4-24
4.6.16	Fencing	4-24
4.6.17	Warning Signs	4-25
4.6.18	Winter Protection	4-25
4.6.19	Piping and Channels	4-25
4.6.20	Flow Distribution Structures.....	4-26
4.6.21	Inlet/Outlet Structures.....	4-26
4.6.22	Drain Structures.....	4-27
4.6.23	Overflows.....	4-27
4.6.24	Flow Measurement	4-27
4.6.25	Shape	4-28
4.6.26	Berms	4-29
4.6.27	Surface Treatment.....	4-30

4.6.28	Servicing.....	4-30
4.6.29	Maintenance Facilities.....	4-30
4.7	MECHANICAL SECONDARY TREATMENT PLANTS.....	4-30
4.8	WETLANDS AND AQUATIC SYSTEMS.....	4-31
4.8.1	Constructed Wetlands.....	4-31
4.8.2	Natural Wetlands.....	4-32
4.9	SOLIDS HANDLING, TREATMENT, AND DISPOSAL OR BENEFICIAL USE.....	4-33

PART 5 – COLLECTIVE GROUND DISPOSAL SYSTEMS

5.1	GENERAL.....	5-1
5.2	SITE EVALUATION and SEPARATION DISTANCES.....	5-1
5.2.1	Evaluation of Soil and Hydrogeological Factors.....	5-1
5.2.2	Soil Profile and Site Investigations.....	5-1
5.2.3	Effluent Quality Classification.....	5-3
5.2.4	Horizontal Separation.....	5-4
5.2.5	Vertical Separation For Ground Disposal Systems.....	5-6
5.3	ABSORPTION TRENCHES.....	5-7
5.3.1	General.....	5-7
5.3.2	Slope.....	5-9
5.3.3	Lot Sizes.....	5-9
5.3.4	Material.....	5-9
5.3.5	Drainage Pipe Length.....	5-10
5.3.6	Construction.....	5-11
5.4	DOSING.....	5-12
5.4.1	General.....	5-12
5.4.2	Dosing Frequency and Volume.....	5-12
5.4.3	Methods of Effluent Dosing.....	5-13
5.4.4	Pump Dosing.....	5-13
5.4.5	Siphon Dosing.....	5-14
5.5	DEEP ABSORPTION TRENCHES.....	5-14
5.6	BUILT-UP MOUNDS.....	5-14
5.6.1	Design of Mound Systems.....	5-14
5.6.2	Location.....	5-15

5.7	GRAVELLESS AGGREGATE EFFLUENT DISPERSAL SYSTEMS	5-16
5.8	RAPID INFILTRATION BASINS	5-16
5.9	SITE PROTECTION	5-17
5.10	DISPOSAL FIELD PROTECTION	5-17

PART 6 – OUTFALLS

6.1	GENERAL	6-1
6.1.1	Effluent and Environmental Monitoring	6-1
6.1.2	Structural and Operational Integrity	6-2
6.1.3	Location and Depth	6-2
6.1.4	Initial Dilution Zone: Water Bodies	6-2
6.2	FEASIBILITY REPORT	6-2
6.3	PRE-DESIGN REPORT	6-7
6.3.1	Previous Studies	6-7
6.3.2	Field Work	6-7
6.3.3	Design Criteria	6-7
6.3.4	Environmental Assessment Study	6-8
6.3.5	Environmental Monitoring	6-10
6.3.6	Reporting	6-11
6.4	DETAILED DESIGN	6-11
6.4.1	General	6-11
6.4.2	Design Drawings	6-11
6.4.3	Horizontal Controls	6-11
6.4.4	Routing	6-11
6.4.5	Diffuser Design	6-12
6.4.6	Hydraulics	6-12
6.4.7	Materials	6-12
6.4.8	Joints	6-14
6.4.9	Depth of Cover	6-14
6.4.10	Protection	6-14
6.4.11	Weighting	6-15
6.4.12	Construction Considerations	6-15
6.5	SURVEYS AND APPROVALS	6-16
6.5.1	Surveys	6-16
6.5.2	Approvals	6-16

6.6	POST DISCHARGE MONITORING.....	6-17
6.6.1	General.....	6-17
6.6.2	Outfall Performance Assessment.....	6-17
6.6.3	Long Term Maintenance Monitoring and Visual Inspections.....	6-18
6.7	OPERATION AND MAINTENANCE OF OUTFALLS.....	6-19

APPENDICES

Appendix I	INAC Guidance Documents for Environmental Assessments
Appendix II	Classes of Cost Estimates
Appendix III	Wastewater Facility Classification and Operator Certification
Appendix IV	Initial Dilution Models
Appendix V	Metals and Alloys for Marine Service
Appendix VI	Government Agencies to be Contacted Prior to Design of Wastewater Facilities
Appendix VII	First Nations Wastewater Emergency Response Plan Guide
Appendix VIII	Checklist for Feasibility Report
Appendix IX	Checklist for Pre-design Report
Appendix X	Checklist for Design Brief and Final Design Drawings
Appendix XI	Operation and Maintenance Manual and Operation and Maintenance Plan for Wastewater Systems – Checklist
Appendix XII	Terms of Reference for Performance Monitoring Plan for Wastewater Treatment Facilities
Appendix XIII	Glossary and Abbreviations
Appendix XIV	References

POLICY STATEMENT #1 HEALTH AND SAFETY

- 1) All facilities shall be designed to eliminate or minimize the need for confined space entry.
- 2) If confined spaces are created, repaired or modified as part of the capital project, the following documents must be prepared by a qualified person and in accordance with the most recent version of the WorkSafeBC Occupational Health and Safety Regulation:
 - a) A list of confined spaces;
 - b) A written hazard assessed for each confined space or each group of confined spaces presenting similar hazards; and,
 - c) Written entry procedures for each confined space or each group of confined spaces presenting similar hazards.

The above documents must be acceptable to the applicable health and safety regulatory agencies and must be included in the O & M Manual.

- 3) All facilities shall be designed to conform to all Federal, Provincial and other relevant legislations and guidelines for worker safety, fire protection, ventilation, etc.

POLICY STATEMENT #2

DEVELOPING OPTIONS FOR WASTEWATER COLLECTION, TREATMENT AND DISPOSAL OR REUSE

- 1) In general, options that incorporate facilities and processes that are robust, simple to operate and have minimal maintenance requirements shall be given priority.
- 2) Existing ground disposal systems shall be retained where feasible. In developing options for treatment and disposal of wastewater, first priority shall be given to the improvement or expansion of any existing individual on-site or collective ground disposal systems.
- 3) If individual on-site ground disposal is considered unfeasible, first priority should be given to connecting to any existing wastewater treatment/disposal facility owned by any adjacent First Nations community or Municipality and operated under a Municipal Type Service Agreement (MTSA). A most economical and sustainable option should be considered.
- 4) If the MTSA approach is unfeasible, collective ground disposal systems shall be implemented where this is determined to be technically feasible.
- 5) If ground disposal is not feasible, then discharge to surface water will be considered.
- 6) For collective systems, priority shall be given to the use of lagoon treatment systems rather than mechanical treatment systems.
- 7) Option analysis for wastewater treatment systems (including septic tanks, stabilization lagoons and mechanical treatment plants) shall include long-term management of solids residuals (sludge, septage, biosolids, etc.).
- 8) Notwithstanding the above, analysis of options for wastewater collection, treatment and disposal or reuse shall include consideration of capital cost, operation and maintenance cost, and life cycle cost. A most cost effective option shall be considered.
- 9) Notwithstanding the above, any selected options for wastewater treatment and disposal shall be supported by an environmental assessment.
- 10) When the average wastewater flow and/or load contributing service population to the collective treatment facilities reaches 90% of the design value(s), a review shall be undertaken to identify expansion needs in light of growth projections. The potential for delaying the need for expansion through activities such as installation of low water use fixtures and reduction of inflow and infiltration shall be considered.

POLICY STATEMENT #3 DISCHARGES TO GROUND DISPOSAL SYSTEMS ON THE FEDERAL LANDS

- 1) For wastewater ground disposal from a collective system (i.e., serving five or more house connections or handling a wastewater flow of 9,100 L/d or greater from non-residential facilities),
 - a) The INAC Design Guidelines for Wastewater Systems in BC shall apply:
 - b) Two separate disposal fields or infiltration basins must be provided, each designed to accept the entire design flow, with a third undeveloped field having suitable soil and hydrogeological conditions being retained as a standby. The standby field must be sized capable of accepting the entire design flow.
- 2) For wastewater ground disposal from an individual system (i.e., serving less than five house connections or handling a wastewater flow of less than 9,100 L/d from a non-residential facility), the requirements of the B.C. Sewerage System Regulation (Ministry of Health) and its related policies and standard practice or any future updates shall apply.
- 3) Ground disposal systems should be absorption trenches unless technically not feasible.
- 4) The following ground disposal systems may also be considered where conventional absorption trenches are not feasible:
 - a) deep absorption trenches;
 - b) built-up mounds;
 - c) gravelless aggregate effluent disposal; or
 - d) rapid infiltration basins (after a minimum of secondary treatment).

POLICY STATEMENT #4

EFFULENT QUALITY FOR DISCHARGES TO SURFACE WATERS

Discharges of wastewater to surface waters shall meet the following standards at a minimum. More stringent effluent quality limits shall be met if recommended by the environmental assessment or required by applicable Federal or Provincial legislations or standards.

- 1) For mechanical wastewater treatment plants discharging to marine or fresh surface waters:
 - a) the maximum concentrations of carbonaceous five-day biochemical oxygen demand (CBOD₅) and total suspended solids (TSS) shall not exceed 45 mg/L; and
 - b) the annual average concentration of carbonaceous five-day biochemical oxygen demand (CBOD₅) and total suspended solids (TSS) shall not exceed 25 mg/L.
- 2) For stabilization lagoons discharging to marine or fresh surface waters:
 - a) the maximum concentration of carbonaceous five-day biochemical oxygen demand (CBOD₅) shall not exceed 45 mg/L; and
 - b) the maximum concentration of total suspended solids (TSS) shall not exceed 60 mg/L.
 - c) the annual average concentration of carbonaceous five-day biochemical oxygen demand (CBOD₅) shall not exceed 25 mg/L.
 - d) the annual average concentration of total suspended solids (TSS) shall not exceed 25 mg/L unless the exceedance is caused by algal growth.
- 3) For both stabilization lagoons and mechanical treatment plants discharging to marine or fresh surface waters, the effluent concentration of total residual chlorine shall not exceed 0.02 mg/L if the effluent is disinfected by chlorination. Disinfection by chlorination is generally discouraged. Where chlorination is practiced, it must be followed by dechlorination.
- 4) For both stabilization lagoons and mechanical treatment plants, the concentration of ammonia nitrogen in the effluent shall be such that Federal water quality guidelines for chronic toxicity (such as unionized ammonia of 0.019 mg/L or less) are met at the edges of the defined mixing (dilution) zone.
- 5) For both stabilization lagoons and mechanical treatment plants discharging to marine or fresh surface waters, additional restrictions may apply if so designated in the environmental assessment as necessary to protect the receiving environment.

POLICY STATEMENT #5
MONITORING FREQUENCY FOR DISCHARGES TO SURFACE WATER
AND TO GROUND DISPOSAL SYSTEMS

- 1) Requirements for monitoring of the receiving environment will be set out in the Environmental Assessment Report that is a component of the Pre-design or Design Report.
- 2) For all discharges to marine or fresh surface waters, the monitoring requirements set out in the applicable Federal or Provincial legislations shall apply.

POLICY STATEMENT #6
REGISTERING DISCHARGES UNDER THE BRITISH COLUMBIA
MUNICIPAL SEWAGE REGULATION (1999)

- 1) All effluent discharges to marine and fresh surface waters shall be in compliance with applicable Federal or Provincial legislations.
- 2) For discharges to ground disposal systems that are located outside federal lands,
 - a) Discharges of 22,700 L/d or greater shall be registered under the Municipal Sewage Regulation.
 - b) Discharges of less than 22,700 L/d shall be registered with the B.C. Ministry of Health in accordance with the B.C. Sewerage System Regulation.

POLICY STATEMENT #7

WASTEWATER OVERFLOWS, BYPASSES AND SPILLS

Wastewater discharges that have not been adequately treated, such as treatment plant bypasses, may be acutely lethal to fish according to the 96-hour LC₅₀ bioassay. The Courts have determined that acutely lethal (and in some cases sub-lethal) discharges constitute deleterious substances and hence, such discharges are in contravention of Section 36(3) of the Fisheries Act. This section of the Act prohibits the deposition of a deleterious substance of any type into water frequented by fish unless the deposition is authorized.

Wastewater also contains several substances, such as suspended solids and organic material that can degrade receiving water quality (e.g. dissolved oxygen depression) and negatively affect fishery resources. While it is recognized that wastewater treatment plant upgrading projects may result in improved treatment and effluent quality in the long term, wastewater bypasses that occur in the absence of an authorization will likely be in violation of the Fisheries Act. Wastewater system owners should be aware that third parties (such as non-government organizations and members of the general public) can lay charges under Canadian environmental legislation including the Fisheries Act.

1) Pumping Station Overflows

- a) Overflows of untreated or partially treated wastewater from pumping stations leading into waters and other sensitive environments are not allowed. Means to prevent overflows may include one or more of temporary storage, emergency power unit, or receptacle for emergency power.
- b) The Operation and Maintenance Manual and the Emergency Response Document must be prepared and address spill and overflow handling procedures. Refer to the emergency procedures outlined in the First Nations Wastewater Emergency Response Plan Guide (Appendix VII or www.inac.gc.ca/extranet).

2) Wastewater Treatment Bypasses

- a) Bypasses of untreated or partially treated wastewater leading into waters and other sensitive environments are not allowed.
- b) Requests to discharge raw, screened or otherwise inadequately treated wastewater into surface waters can arise during wastewater treatment plant construction, alteration or maintenance projects. Proponents of wastewater bypass proposals shall pursue alternatives to discharging into fishery waters. Where bypass discharges to surface waters are unavoidable (e.g., cannot be avoided through proper planning), every effort shall be made to minimize the impact of the discharges on the receiving waters. These efforts should include, but not be limited to, timing the bypass to coincide with periods of maximum dilution and avoiding the sensitive life stages of fish (e.g. juvenile and spawning salmon) and their habitats. The Fisheries and Oceans Canada (DFO) should be contacted for information on timing and fishery resource sensitivities. Expedient construction schedules should be

- c) implemented to minimize the duration of bypasses. Written approval of the Fisheries and Oceans Canada and/or the B.C. Ministry of Environment (depending on who has jurisdiction), must be obtained prior to initiation of any discharges to surface waters.
- d) Appropriate effluent testing and receiving environment monitoring programs shall be designed with early input from DFO or MOE and carried out by Qualified Professionals prior to and during any bypass period to determine if there are adverse effects, and if so, the extent and severity of the impacts. Remedial contingency plans shall be available for immediate implementation where bypass discharges result in an unacceptable degradation of receiving water quality or other unacceptable impact.

POLICY STATEMENT #8 MANAGEMENT OF WASTEWATER SOLIDS RESIDUALS

- 1) Options for wastewater treatment, including septic tanks, stabilization lagoons and mechanical treatment plants, shall include options for long-term treatment and disposal or beneficial use of solids residuals (sludge, septage, biosolids, etc.).
- 2) Disposal of wastewater solids residuals to a water body is strictly prohibited.
- 3) Solids residuals must be sent to an authorized facility such as a municipal wastewater treatment facility that accepts this type of waste.
- 4) Land drying or storage of wastewater solids residuals must be supported by a hydrogeological impact study undertaken by a Qualified Professional.
- 5) Any beneficial use of biosolids must be supported by a Land Application Plan and must comply with the most recent publication of the B.C. Organic Matter Recycling Regulation (see Appendix VI for contact information).

POLICY STATEMENT #9 GENERAL

- 1) Equipment and materials selection shall favour locally available spare parts and service.
- 2) Collective wastewater collection and treatment systems shall be classified during the Design Stage by the Environmental Operators Certification Program of British Columbia.
- 3) Operator training and certification requirements shall be identified and a suitable training plan prepared, at the latest, during the Design Stage.

PART 1 – PROJECT SUBMISSIONS

1.1 GENERAL

This document contains a number of Policy Statements that relate to project submissions and design of wastewater systems. It is essential that users of these guidelines carefully review the Policy Statements prior to initiating the preparation of project submissions and design of systems. In the event that any Policy Statement is in conflict with applicable Federal legislations or standards, the Federal legislation or standards shall apply. It is also essential that INAC's Practical Guide for Capital Projects be followed. Any conflict between these guidelines and Practical Guide for Capital Projects shall be discussed with INAC wastewater engineers.

1.1.1 Document Submissions

Part 1 specifies engineering standards for services to be provided for the Feasibility Study, Pre-design and Design of wastewater systems. These include wastewater collection, pumping, treatment and disposal or reuse systems.

Documents to be submitted to INAC at various stages in the capital project approval process shall include but not be limited to:

- 1) Feasibility Report (see Section 1.2, Feasibility Report);
- 2) Pre-design Report (see Section 1.3, Pre-design Report);
- 3) Summary of the Basis of Design (see Section 1.4, Design Report);
- 4) Environmental Assessment Scoping Report or Environmental Assessment Report (see Appendix I);
- 5) Preliminary Design Drawings;
- 6) Final Design Drawings (see Section 1.5);
- 7) Specifications (see Section 1.6);
- 8) Cost Estimates (see Appendix II) including Life Cycle Cost Analysis;
- 9) Operation and Maintenance Documents, including Operation and Maintenance Manuals and Plans and Emergency Response Plans where applicable (see Section 1.9, Operation and Maintenance Information and Considerations);
- 10) Refer to INAC's most recent publication entitled "Practical Guide for Capital Projects" for details on each stage of the project.

Please refer to Appendes for detailed checklist of documents required at various stages of a project. Permits for construction, wastewater discharges, stream crossings, etc., may be required from Federal, Provincial or local agencies (see Appendix VI for contact information). The Band is responsible for obtaining all necessary approvals and permits from the appropriate regulatory agencies.

1.1.2 **Design Period**

The design period for wastewater systems to serve the community shall be at least 20 years, with provision for expansion to accommodate future growth patterns. Phasing of the project shall be considered. In siting major facilities such as trunk sewers and wastewater treatment facilities, a longer term design horizon up to 40 years should be considered to minimize the risk of future land use conflicts that could dictate the need for relocation or replacement of major works. Equipment that has a life span of less than 20 years (e.g., pumps, UV units, etc.) shall be designed to service the community for at least 10 years, with provision for expansion to accommodate a 20 year design capacity.

1.1.3 **Option Analyses**

Where site conditions permit, the least complex, the easiest to maintain, and the most economical wastewater management systems shall be used (see Policy Statements). Standards for many of the more recently developed methods of wastewater treatment and disposal or reuse are not included in these guidelines. It is expected that these guidelines will be reviewed and revised periodically, and that guidelines for other proven alternative systems will be prepared as more experience and research data become available. Until that time, alternative systems will be considered provided that the system is based on engineering and scientific principle and that the system has been proven elsewhere under similar conditions.

1.1.4 **Operation and Maintenance Documents**

Operation and Maintenance Manual and Plan and Emergency Response Plan (O&M Documents) are to be submitted as described in Section 1.9.

1.1.5 **Units**

Metric (S.I.) units shall be used.

1.1.6 **Compliance with INAC and Regulatory Requirements**

These Guidelines make reference to the technical aspects of Provincial regulations that govern wastewater treatment and disposal. These Provincial legislations have administrative approaches that differ from INAC procedures. It is emphasized that the technical aspects of Provincial legislations referred to in these Guidelines are applicable to the design, construction and operation of INAC facilities, and that it is the responsibility of the Band to ensure that all of the necessary INAC administrative and technical procedures and requirements are met.

1.1.7 **Sustainability**

Designers of wastewater systems should consider sustainability issues during planning, design and construction. Sustainability issues should include minimization of disruption to the natural environment, low energy use and reuse of resources (water and solids) where feasible.

1.2 **FEASIBILITY REPORT**

The Feasibility Report presents a preliminary development and evaluation of alternative concept designs for wastewater collection, treatment and disposal including Class C cost estimates (capital, operating and life cycle costs). The primary purpose of the report is to identify concept designs that can meet the project requirements at reasonable cost, including recommendations for advancing the preferred alternative for more detailed development in the Pre-design Report. The Feasibility Report should include conceptual designs for wastewater collection, treatment, and disposal or reclamation and reuse (if proposed), as well as long term solutions for solids handling, treatment and disposal or beneficial use. The conceptual designs shall also include operation and maintenance considerations. Refer to Policy Statements and Checklist in Appendix VIII.

The Feasibility Report shall include a review of the available information including present and future wastewater flows and loads, site topography, geology, climate, groundwater, and surface water, as well as Environmental Scoping Report such as identification of known fish and wildlife habitat issues (e.g., rare and endangered species, critical habitat areas, and impacts on neighbouring properties). Where discharges to surface waters are proposed, the Feasibility Report shall include the components set out in Section 6.2 and preliminary dilution calculations shall be undertaken to establish approximate dilution ratios (see Part 6.2, Outfalls, Feasibility Report for additional detail). Where discharges to ground are proposed, on-site tests shall be undertaken to establish appropriate soil wastewater loading rates, and a preliminary evaluation of the discharge subsurface travel time, effect on groundwater table, and distance to surfacing shall be included (see Part 5, Ground Disposal Systems for additional detail).

For new wastewater facilities, where appropriate, the Feasibility Report may be divided into two separate phases. Phase 1 shall include identification and evaluation of at least two concept alternatives using the available information (including capital, operating, and life cycle costs). In cases where sufficient information is available in Phase 1 to adequately develop and evaluate the alternatives and to select the preferred alternative, the Phase 1 Feasibility Report shall include recommendations for the preferred alternative to be advanced to Pre-design, and the Phase 2 Feasibility Report will not be required. In this case, the Phase 1 Feasibility Report shall include Class C cost estimates for the recommended alternative (including capital, operating, and life cycle costs). In cases where information is insufficient to develop a Class C cost estimate, the Phase 1 Report may be based on a Class D cost estimate, provided that a Class C estimate is developed as a component of

Phase 2. A project submission flow chart illustrating the phases of the Reports is shown in Figure 1-1.

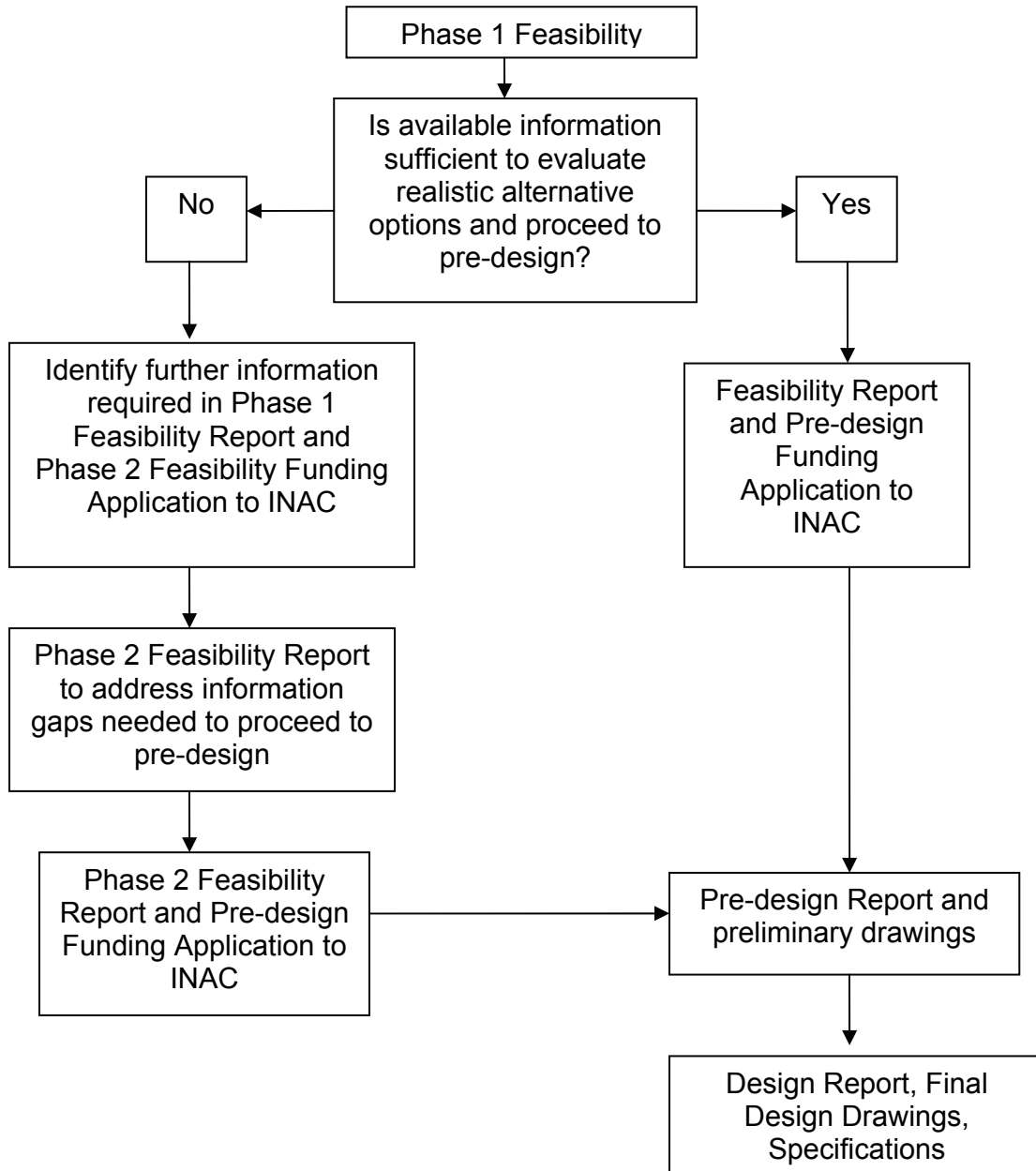

FIGURE 1-1: PROJECT FLOW CHART

The work carried out in the Phase 1 Feasibility Report may identify information gaps that must be addressed before the concept alternatives can be adequately evaluated. In that case, the Phase 1 Feasibility Report shall contain recommendations for the work needed to undertake the Phase 2 Feasibility Report, including identification of specific additional studies that are needed to address information gaps, together with estimated costs for carrying out these studies. The Phase 2 Feasibility Report (where required) shall include the results of any additional studies needed to complete the development and analysis of concept alternatives, as well as recommendations for the preferred alternative to be advanced to Pre-design, and Class C cost estimates for the preferred alternative.

Only projects where there is a need to acquire further information to develop and evaluate realistic options for wastewater treatment and disposal should have the feasibility study split into two phases. For example, projects where the receiving environment is particularly sensitive may require a phased feasibility stage in order to adequately determine the treatment requirements.

The Feasibility Report(s) shall include but not be limited to the following applicable items (relevant sub-consultant reports shall be attached as appendices):

1.2.1 **Title**

1.2.2 **Title Page**

1.2.3 **Table of Contents**

1.2.4 **Summary**

- a) Findings
- b) Conclusions
- c) Recommendations

1.2.5 **Introduction**

- 1) project background, rationale and objectives.
- 2) Scope of project.

1.2.6 **Existing Wastewater Facilities**

- 1) Existing service areas, wastewater collection and treatment facilities, disposal/reuse of treated effluent, management of waste solids, known problems (e.g., odours, age and capacity of facilities).
- 2) Summary of the outcome and recommendations from the most recent facilities assessment report or effluent discharge risk assessment report or other relevant reports, if available, and any works done since the reports.

- 3) Wastewater and sludge quantity and quality – existing and projected wastewater flows (ADWF and PWWF) and contaminant concentrations, mass loadings to treatment facilities, quantity and quality of waste solids, inflow and infiltration to wastewater collection system, potential impact of low water use fixtures on wastewater flows, design criteria for treatment and handling of wastewater and waste solids.

1.2.7 **Land Use and Development**

- 1) Existing and projected development (residential, industrial, commercial and institutional).
- 2) Existing and projected service population.
- 3) Community Physical Development Plan (if any and valid).

1.2.8 **Regulatory and Environmental Issues**

- 1) Applicable Federal, Provincial and local government regulations and guidelines for discharge and beneficial use of wastewater and waste solids.
- 2) Environmentally sensitive areas.
- 3) Known contamination issues.
- 4) Surface and groundwater character and flow regimes.
- 5) Water supply issues.
- 6) Preliminary dilution modeling.
- 7) Soil type and permeability.
- 8) Local drainage.
- 9) Capacity of local receiving environment to accept treated wastewater (surface discharge, ground disposal, spray irrigation, etc.).
- 10) Potential for beneficial use of biosolids.

1.2.9 **Concept Alternatives for Wastewater System**

- 1) Wastewater collection.
- 2) Wastewater treatment.
- 3) Disposal or reuse of treated effluent.
- 4) Long-term management of waste solids (including biosolids and septage).
- 5) Class C cost estimates (capital, 20-year operating and life cycle cost).
- 6) Part 3 of these Guidelines should be followed for wastewater collection, Part 4 should be followed for wastewater treatment alternatives, Part 5 should be followed for ground disposal alternatives, and Part 6 should be followed for outfall disposal alternatives.
- 7) Operation and Maintenance costs for all options, including requirements for facilities classification and operator certification, should be included. For certain projects, the First Nation may have to consider hiring an outside Certified

Contractor to operate the system, and train First Nations members to a certified status. This should be included in the estimate of operation and maintenance costs.

1.2.10 **Analysis of Alternatives**

- 1) Cost comparison (capital, O&M, life cycle).
- 2) Technical issues (reliability).
- 3) Operating complexity.
- 4) Ability to meet project objectives and regulatory needs.
- 5) Expandability.
- 6) Social and environmental factors (odours, visual aesthetics, traffic, archaeology values, habitat issues).
- 7) Land area.

1.2.11 **Environmental Assessment Scoping Report**

This is a stand alone document covering the requirement of CEAA (Canadian Environmental Assessment Act) – refer to documents in INAC’s Practical Guide for Capital Projects titled “A Summary of the Environmental Assessment Screening Process for First Nations Capital Projects” and “INAC General Terms of Reference for Environmental Assessment” – these are attached in Appendix I of these guidelines.

1.2.12 **Regulatory Issues**

Regulatory impacts or permits associated with Federal, Provincial or local government jurisdictions (refer to Appendix VI for further information).

1.2.13 **Land Encumbrance Check**

Required to confirm ownership of any lands that will be impacted by the selected option.

1.2.14 **Timber Permit Assessment**

Document if Permit required.

1.2.15 **Conclusions and Recommendations**

- 1) Identification of preferred alternative based on existing information.
- 2) Identification of additional information needed to adequately develop and analyze alternatives (if any).
- 3) Recommendations for Phase 2 Feasibility Report or for advancing preferred alternative to Pre-design stage.
- 4) Class C cost estimate for preferred alternative.
- 5) List of Federal, Provincial and local government permits and other authorizations needed for implementation of recommended alternative.
- 6) Recommendations for additional studies to be carried out during Pre-design.

1.3 ***PRE-DESIGN REPORT***

The Pre-design Report presents a more detailed analysis of the preferred concept alternative identified in the Feasibility Report, makes recommendations for project implementation, and forms the technical basis for Final Design. The Pre-design Report quantifies and refines the concept alternative that was brought forward from the Feasibility Report, and it includes all of the information needed to proceed to Detailed Design. This may include detailed site investigations (e.g., geotechnical investigations). Refer to Checklist in Appendix IX.

Where discharges to surface waters are proposed, the Pre-design Report shall include the components set out in Section 6.3.

Architectural, structural, mechanical, and electrical designs are usually excluded. Sketches may be desirable to aid in presentation of a project. Outline specifications of process units, special equipment, etc. will be required if warranted by the unusual or complex nature of any component of the proposed system.

Issues that should be addressed at the Pre-design stage include the following:

- odour control;
- noise abatement;
- visual aesthetics;
- setbacks;
- confined space entry;
- cross connection control;
- site security measures;
- public safety;
- communication systems;
- control systems;
- building envelope requirements;
- operator safety;
- chemical handling, storage and disposal;

- fire protection;
- need for washroom facilities;
- need for laboratory facilities;
- classification of wastewater facilities (Environmental Operator Certification Program); and
- identification of candidate operators for wastewater facilities.

The Pre-design Report shall, where pertinent, present the information according to the outline shown below. The Feasibility Report(s) may be referenced and summarized as appropriate in the Pre-design Report. However, the Pre-design Report shall contain sufficient detail to function as a stand-alone document. In general, the information contained in the Feasibility Report will be expanded and developed to a greater level of detail in the Pre-design Report. Design criteria, assumptions used and any additional information which may be required before final design can proceed shall be identified in the appropriate sections of the Pre-design Report.

1.3.1 **Title**

1.3.2 **Title Page**

1.3.3 **Table of Contents**

1.3.4 **Summary**

- 1) Findings
- 2) Conclusions
- 3) Recommendations

1.3.5 **Introduction**

1) **Background**

- Information of necessity for project.

2) **Scope of Project**

- Brief description of the project including major components.

1.3.6 **Existing Conditions and Projections**

1) **Design Period**

- Period for which facilities are designed to serve community.

2) Land Use

- Existing area, expansion, annexation, inter-municipal service, ultimate planning area.
- Current and proposed future (if known) zoning, residential, commercial and industrial land use, population densities, industrial types and concentrations.

3) Demographic and Economic Data

- Past population growth and trends, projections for design life of facility.
- Future economic prospects for the region and its impact on the community population.

4) General Physical Conditions and Climate

- Topography, general geology, hydrogeology, and their effects on the project.
- Meteorology, precipitation, run-off, flooding, etc., and effect on project.

5) Water Use, Wastewater Flows and Waste Loads

- Present and estimated future water consumption including demand due to winter "bleeding" (use metering data if possible).
- The present and estimated future wastewater flows as described later in this Guideline (use flow monitoring data if possible and verify by additional monitoring if necessary).
- Flows shall be broken down into contributions from:
 - Band community residential (i.e., housing from band members);
 - Institutional (school, nursing station, etc.);
 - Economic development, including non-community residential (e.g. leased land/housing, commercial, and campgrounds, mobile home parks, etc.);
 - and
 - Infiltration/inflow.
- Physical, chemical, and biological characteristics of the wastewater and concentrations of contaminant for present and future wastewater flows.

6) Regulations, Agreements, Permits

- Relevant existing by-laws, rules and regulations of the Bands and of neighbouring municipalities with whom the Band has municipal-type service agreements.
- Relevant existing municipal-type service agreements.
- Relevant existing approvals or permits from regulatory agencies.
- Monitoring and/or enforcement provisions including inspection, sampling, detection, penalties, etc.

1.3.7 **Existing Facilities Evaluation (with appropriate drawings)**

1) Existing Collection System

- Inventory of existing sewers.
- Adequacy to meet project needs (age, condition, hydraulic capacity tabulation).
- Gauging and infiltration/inflow (including winter "bleeding", and house roof and perimeter drains) analysis.
- Overflows and required maintenance, repairs, improvements, and methods for control.
- Repair, replacement, and stormwater separation requirements.
- Evaluation of costs for treating infiltration/inflow (including winter "bleeding") versus costs for rehabilitation or operational changes of system.
- Establish renovation priorities, if appropriate.
- Cost estimate for annual operation and maintenance requirements with breakdown including labour, materials, equipment and power.

2) Existing Treatment Works Site

- Area for expansion.
- Terrain and topography.
- Subsurface conditions.
- Isolation and habitation.
- Protection of water supply against contamination.
- Enclosure of units, odour control, landscaping, etc.

3) Existing Treatment and Disposal Facilities

- Capacities and performance of units (wastewater treatment, effluent disposal, sludge processing, and sludge disposal).
- Age and condition.
- Suitability of incorporating into proposed project.
- Facilities to be retained, modified, or demolished.
- Outfall: age, length, depth, condition, acceptability with respect to receiving water quality guidelines or regulations.

1.3.8 **Proposed Project Development**

1) Soil, Foundation, Climate and Groundwater Conditions

- Character of the soil through which sewer mains are to be laid.
- Foundation conditions prevailing at sites of proposed structures.
- One in 200-year flood level and considerations given to mitigate problems.
- Depth of frost and considerations given to mitigate problems.

- Elevation of groundwater in relation to subsurface works (consider seasonal fluctuations) and consideration given to mitigate problems.

2) Options

- Where two or more solutions exist for providing wastewater facilities, each of which is feasible and practicable, summarize the options and refer to the Feasibility Report. Give reasons for selecting the one recommended, including simplicity, effluent quality, sludge generation, environmental implications, planning, future expansion needs, financial considerations, and a comparison of the minimum qualifications of the wastewater system operator(s) required for operation of each alternative facility (see Policy Statements.)
- Include a tabulation of the capital works and costs, operation and maintenance requirements and annual costs, and life cycle cost analysis.

3) Water Systems

- Existing and proposed water systems, with reference to their relationship to existing or proposed wastewater facilities, which could be affected by the wastewater facilities or which may affect the operation of the wastewater system, and/or the quantity of the wastewater. Considerations given to prevent contamination of the water system and potential potable water sources.

4) Proposed Collection System

- Inventory of proposed additions
- Protection of potable water system
- Area of service
- Unusual construction problems
- Utility interruption and traffic interference
- Restoration of pavements, lawns, etc.
- Right-of-ways and easements required through private or public lands
- Basement flooding prevention and overflow considerations during power outage or pump station breakdowns

5) Treatment Plant Site Requirements

- Summarize advantages and disadvantages of alternative sites relative to cost, hydraulic requirements, flood control, accessibility, enclosure of units, odour control, landscaping, etc., and isolation with respect to potential nuisances and protection of water supply facilities (refer to Feasibility Report).

6) Proposed Wastewater Treatment Processes

- Establish the adequacy of proposed processes and unit parameters for the treatment of the wastewater under consideration. Include chemical treatment available for reducing waste handling and disposal problems.
- Necessity for pretreatment of any industrial wastewater.

7) Wastewater Disposal Methods and Requirements

- Final discharge points and treatment requirements and potential impacts. Identify all investigations necessary to determine acceptability of proposed treatment and disposal methods.
- For disposal to receiving waters, include the following and refer to Part 6, Outfalls, for additional checklist:

Lakes, Rivers, Streams, and Wetlands

- Upstream wastewater discharges.
- Receiving water base flow (utilize critical flow).
- Background concentrations of receiving waters parameters.
- Downstream water uses including: potable water uses, recreation, agriculture, industrial, etc. with references to downstream water licenses.
- Impact of proposed discharge on receiving waters and uses.

Marine Discharges

- Resources, or potential resources and water uses in the area impacted by proposed discharge.
- Impact of proposed discharge on receiving water and uses.

8) Solids Residuals and Screenings

- Solids Residuals and screenings from the wastewater treatment facilities, including volume, treatment and method of disposal (including required and available land and equipment).
- Land Application Plan if use of biosolids is proposed.

9) Future Expansion

- Summarize planning for future needs.

10) Cost Estimates

- Breakdown of capital costs for proposed works.
- Detailed estimated annual cost of operation and maintenance. (Operation costs should include estimates for heat, lighting, electricity and chemicals. Maintenance cost information should include cost estimates for labour,

materials, equipment, spare parts, specialized tools and the identification of contract requirements including costs.)

- 20-year life cycle costing analysis.
- Proposed cost sharing method (capital and O&M) between the Band and INAC if wastewater flows from economic development are to be collected and treated.

11) Legal, Regulatory Agencies and Other Considerations

- Recommended changes to existing and/or new by-laws, rules and regulations, agreements, approvals and/or permits.
- Contractual considerations and intercommunity cooperation.
- Public information and education.
- See Appendix VI for partial list of agencies to be contacted.

12) Facility Classification and Operator Training

- Probable facility classification according to B.C. Environmental Operator Certification Program.
- Identification of at least two candidate operators for wastewater facilities in consultation with Band.
- Operator training plan, including cost estimates.

1.3.9 **Appendices: Technical Information and Design Criteria**

1) Collection System

- Design tabulations: design flow, capacity, size, velocities, etc.
- Pump station calculations, including energy requirements
- Special appurtenances
- Stream crossings
- System map (fold out report size) showing design flows and capacities of collectors and pumps

2) Process Facilities

- Criteria selection and basis
- Hydraulic and organic loadings - minimum, average, maximum, and effect on wastewater and sludge processes
- Unit dimensions
- List of major equipment
- Rates and velocities
- Detentions
- Concentrations
- Recycle
- Chemical additive control
- Physical control and flow metering

- Removals, effluent concentrations, etc.
- Energy requirements
- Flexibility

- 3) Disposal and/or Reuse Facilities (for effluent and waste solids/septage)
- 4) Process Diagrams and Hydraulic Profile
- 5) Draft Operation and Maintenance Documents

These shall be stand alone documents and shall be finalized once construction is completed. The finalized document will be frequently used by the operator(s).

Provide draft Operation and Maintenance documents including Operation and Maintenance Manual, System Operation and Maintenance Plan and Emergency Response Plan. Refer to Section 1.9 (Operation and Maintenance Information and Considerations).

- 6) Support Data

- Outline unusual specifications, construction materials, and construction methods
- Maps, photographs, diagrams

- 7) Environmental Assessment Study Report

Provide a stand alone document covering the requirements of CEAA (Canadian Environmental Assessment Act) – refer to documents in INAC’s Practical Guide to Capital Projects titled “A Summary of the Environmental Assessment Process for First Nations Projects” and “General Terms of Reference for Environmental Assessments” (these are attached in Appendix I of these guidelines – in addition, specific efforts should focus on the following:

- Results of investigations carried out as part of the project, including environmental impact of long-term ongoing discharge of wastewater effluent to the receiving environment, and how this information has been used to minimize environmental impacts.
- Detailed descriptions of all activities to be carried out during the life-cycle of the project, how these activities might impact the environment, and how the impacts will be mitigated.
- Design implementation information.
- Environmental monitoring plan to document environmental compliance, and to assess the impacts of the discharge on the receiving environment. Refer to the Environmental Assessment Scoping Report (Section 1.2.12).

1.4 DESIGN REPORT

A summary of the rationale and complete design criteria and calculations shall be submitted, along with the final design drawings (Section 1.5) and specifications (Section 1.6) for the proposed project. An Environmental Assessment Report as described in the INAC Practical Guide for Capital Projects titled “General Terms of Reference for Environmental Assessments” and “A Summary of the Environmental Assessments Screening Process for First Nations Capital Projects” shall be appended to the Design Report (see Section 1.3.10(7) if not yet completed at the Pre-design Phase.

The Design Brief shall include the following elements at a minimum (also refer to Checklist in Appendix X):

1.4.1 General

- 1) Population served (present and future).
- 2) Area served (present and future) in hectares.
- 3) Per capita wastewater flows (average daily, peak hourly, seasonal minimum and maximum).
- 4) Flows due to winter household "bleeding".
- 5) Design flows used for the various components of the wastewater system.
- 6) Method of handling power outages or equipment failure.
- 7) Monitoring requirements, facilities and equipment.
- 8) Hydraulic profile of the collection, treatment, and disposal facilities.
- 9) Permits for construction, wastewater discharges or disposal, stream crossings, construction in navigable waters etc.
- 10) Right-of-ways and easements.
- 11) Considerations given to preventing contamination of existing and proposed potable water systems and potential sources of potable water, both surface water and groundwater and both on and off Indian lands, which could be within the zone of influence of the wastewater facilities. Include a report size drawing showing the relative locations of the foregoing.
- 12) Where discharges to surface waters are proposed, the Design Report and the Design Drawings (Section 1.5) shall include the components set out in Section 6.4.

1.4.2 Collection

- 1) Design flow, capacity and velocity of each sewer line segment.
- 2) Capacity of pumps, complete with pump(s) and system curve(s) for high water and low water levels in wet well.

- 3) Pump station operating details (controls, alarms, emergency overflows and the impact of overflows, etc.).

1.4.3 **Treatment**

- 1) Substantiation for proposed treatment facilities.
- 2) Raw wastewater characteristics and final effluent characteristics (compared to acceptable environmental standards and regulations or requirements by agencies).
- 3) Waste loadings on treatment systems.
- 4) Efficiencies of treatment works.
- 5) Reserve capacity available for future requirements and proposed method of accommodating future requirements.
- 6) Design life of components.
- 7) Description of each significant unit process.
- 8) Proposed method and pertinent details of final sludge (waste solids) disposal or beneficial use.
- 9) Identification and characteristics of receiving waters.
- 10) CSA certification documentation for septic tanks (if applicable).

1.4.4 **Disposal/Reuse**

- 1) Details of outfall design, including location, structural details, dilution analyses as outlined in Part 6, Outfalls, to substantiate design.
- 2) Details of parameters for wastewater effluent disposal to ground, as outlined in Part 5, Ground Disposal, to substantiate design.
- 3) Details of water reclamation and reuse systems (if included).
- 4) Design life of disposal or reuse system.

1.4.5 **Cost Estimates**

Class A estimate as defined in Appendix II.

1.4.6 **Draft Operation and Maintenance Documents**

These stand alone documents shall be drafted if not done during the Pre-design Phase. Refer to Section 1.9 (Operation and Maintenance Information and Considerations).

1.4.7 **Facility Classification and Operator Training Plan**

Wastewater facilities shall be classified according to the B.C. Environmental Operators Certification Program.

The Operator Training Plan that was developed during the Pre-design Phase (Section 1.3.8(12)) should be implemented so that operator training and certification is completed before commissioning of facilities. The Operator Training Plan should include participation of the operators during detailed design, construction and commissioning of facilities, so that the operators are familiar with facility layout, equipment location and requirements, the Operation and Maintenance Manual, design drawings, etc. See also Section 1.9.2(3) and Appendix III.

1.4.8 **Commissioning Plan**

Provide a written description of procedures that should be conducted for start-up and commissioning of the wastewater facilities, with special attention to wastewater treatment facilities and pumping stations. Provide detailed descriptions of tests that should be done prior to start-up to demonstrate that the facilities are capable of meeting the design flows, and other performance criteria. Refer to INAC's Commissioning Guideline for Water Works for general guidance or any future updates. The commissioning plan shall be submitted to INAC with the design stage deliverables.

1.4.9 **Performance Monitoring Plan**

Provide a written description of procedures that should be followed within one year after completion of Construction and Commissioning. Refer to Appendix XII for Terms of Reference for performance monitoring plan. The performance monitoring plan shall be submitted with the design stage deliverables.

1.4.10 **Environmental Assessment Study Report**

A stand alone Environmental Assessment Study Report should be included unless this was completed and submitted as a component of the Pre-design Phase.

1.5 DETAILED DESIGN DRAWINGS

All design drawings shall be sealed and signed by a Professional Engineer (or Limited License Engineer where appropriate) registered in British Columbia who is qualified in the appropriate design discipline.

1.5.1 **General**

The drawings shall be clear and legible. They shall be drawn to a scale which will permit all necessary information to be legible and clearly shown. Electronic version such as in PDF shall be submitted.

Where pertinent, the following shall apply to drawings for proposed wastewater systems (refer also to Checklist in Appendix X):

- 1) Suitable title
- 2) The name of the Reserve, Community, Band, and/or Tribal Council
- 3) Bar Scale in metric units
- 4) Datum used
- 5) North point
- 6) Date
- 7) Name and address of the Qualified Professional
- 8) Imprint of Engineer's registration seal with the Engineer's signature and date of signature
- 9) Locations, elevations, and logs of test borings

1.5.2 **Location Plan**

A drawing showing the general vicinity of proposed works. A site plan shall also be included in the top right corner. A drawing index and legend can also be included on this drawing.

1.5.3 **General Layout Drawings**

Comprehensive drawings of existing and proposed wastewater facilities shall be submitted for projects involving new wastewater systems and substantial additions to existing systems. The drawing(s) shall show the following:

1) **Location and Flow Diagrams**

- a) Location and extent of the tributary area feeding the pump stations and treatment works.
- b) Ground elevations (including contours where appropriate).
- c) Size and direction of flow of all existing and proposed sanitary sewers, pumping stations, forcemains, treatment and disposal facilities.
- d) Dimensions and relative elevations of structures.
- e) Outline form of equipment.
- f) Water levels.
- g) Location of facilities with respect to known references such as property lines, right-of-ways, roads and section lines.

2) **Geographical Features**

- a) Topography and elevations of existing or proposed streets, streams or water surfaces, pumping station sites, and treatment facilities sites shall be clearly shown - contour lines at suitable intervals should be included.

- b) Streams - The direction of flow in all streams, and high and low water elevations of all water surfaces at sewer outlets and overflows shall be shown.
- c) Boundaries - The boundary lines of the community and the service area shall be shown.

1.54 **Detailed Drawings**

Detailed drawings shall consist of: plan views, elevations, sections and supplementary details which, together with the specifications and general layout drawings, provide sufficient information for construction of the proposed works. The drawings shall also include:

1) **Plan and Profile of Sewers and Forcemains**

- a) Profiles shall have a horizontal scale of not more than 1:1000 for rural density and 1:500 for municipal density, and vertical scale of not more than 1:100, with both scales clearly indicated.
- b) Plan views shall be drawn to a corresponding horizontal scale and shall be shown on the same sheet as the vertical profile.
- c) Location of streets and sewers.
- d) Line of ground surface; size, material and type of pipe; length between manholes; invert and surface elevation at each manhole; and grade of sewer between manholes (all manholes shall be numbered on the profile).
- e) Where there is any question of the sewer being sufficiently deep to serve any residence, the elevation and location of the basement floor shall be plotted on the profile of the sewer which is to serve the house in question – the engineer shall state that all sewers are sufficiently deep to serve adjacent basements except where otherwise noted on the drawings.
- f) Locations of all special features such as inverted siphons, concrete encasements, elevated sewers, etc.
- g) All known existing structures and utilities, both above and below ground, which might interfere with the proposed construction, particularly watermains, gas mains, storm drains, and telephone and power conduits.

2) **Sewer and Forcemain Details**

- a) All stream crossing and sewer outlets, with elevations of the stream bed and of normal and extreme high and low water levels.
- b) All special sewer joints and cross-sections.
- c) All sewer appurtenances such as manholes, lampholes, inspection chambers, cleanouts, inverted siphons, regulators, tide gates, elevated sewers, etc.

3) Wastewater Pumping Stations

- a) Proposed pumping stations, including provisions for future pumps.
- b) Size and location of structures.
- c) Schematic flow diagram(s) showing the flow through various plant units, and showing utility systems serving the plant processes.
- d) Piping, including any arrangements for by-passing individual units (materials handled and direction of flow through pipes should be shown).
- e) Hydraulic profiles showing the flow of wastewater, effluent, and/or sludge.
- f) Test boring and groundwater elevations.
- g) Elevation of high water at the site, and maximum elevation of wastewater in the collection system upon power failure
- h) Maximum hydraulic gradient in downstream gravity sewers when all installed pumps are in operation.
- i) Systems and pump curves.
- j) Location and details of electrical works, fencing, site improvements and any other works related to the pumping stations.

4) Wastewater Treatment Facilities & Disposal Facilities

- a) Location, dimensions, and elevations of all existing and proposed plant facilities.
- b) Topography with contour intervals not greater than 1.0 metre.
- c) Elevations of high and low water levels of receiving waters.
- d) Elevations of the highest known flood level, 1 in 200 year flood level, floor of any structure, outside surrounding grade, important adjacent features such as lake and river water levels.
- e) Size, length, and identity of sewers, drains, and watermains, and their locations relative to plant structures.
- f) Schematic flow diagrams and hydraulic profiles showing the flow through various units at minimum, average and maximum flow.
- g) Type, size, and operating capacity of all pumps.
- h) Outfall structural, weighting and protection details.
- i) Piping in sufficient detail to show flow through the plant, including sludge and chemical lines.
- j) Locations of all chemical storage areas, feeding equipment and points of chemical application.
- k) Locations of all sampling taps and monitoring facilities.
- l) Locations and details of structures, electrical works, fencing, site improvements and any other works related to the treatment and disposal facilities.

1.6 SPECIFICATIONS

Complete technical specifications for the construction of sewers, forcemains, wastewater pumping stations, wastewater treatment plants, outfalls, other disposal facilities, and all other appurtenances, shall accompany the detailed design drawings.

The specifications accompanying construction drawings shall include, but not be limited to, all information not shown on the drawings which is necessary to inform the contractor in detail of the requirements for the quality of materials, workmanship and fabrication of the project. The specifications shall also detail miscellaneous appurtenances, chemicals used, instructions for testing materials and equipment as necessary to meet design standards, and performance tests for the completed works. Commissioning Plan requirements shall be incorporated into the specifications.

A program for keeping existing services in operation during construction shall also be included in the specifications. Should it be necessary to interrupt any service, a shutdown schedule (which will keep inconvenience to all affected parties and pollution effects to an absolute minimum) shall be prepared and strictly followed.

The Canadian National Master Construction Specification (NMCS), published by the Government of Canada, shall be used to the fullest extent possible, subject to the Qualified Professionals' discretion with respect to their professional responsibility for the contents of the project specifications.

1.7 REVISIONS TO PLANS

Revised drawings and/or specifications shall be submitted in time to permit the funding application review by INAC and accepted before any construction work affected by such changes is started.

1.8 ADDITIONAL INFORMATION

Additional information which is not part of the construction drawings, such as headloss calculations, proprietary technical data, copies of deeds, copies of contracts, etc. may be required.

1.9 OPERATION AND MAINTENANCE INFORMATION AND CONSIDERATIONS

1.9.1 Scope

Thorough consideration of the operation and maintenance aspects and of reducing the complexity of operation and maintenance requirements for the proposed and existing facilities must be given during the Pre-design and Design stages of the project.

This section describes the desired format and content of Operation and Maintenance Documents (herein referred to as the O&M documents). The O&M documents prepared by the Qualified Professional shall include the following three separately bound documents:

- Operation and Maintenance Manual (O & M Manual);
- System Operation and Maintenance Plan (O & M Plan); and
- Emergency Response Plan (ERP).

The draft O&M documents must be prepared during the design stage and submitted with the design package. The documentation to be provided by the Manufacturer/Contractor (see Section 1.9.2 (5)) shall be submitted to the Qualified Professional for review prior to commissioning; this requirement shall be clearly stated in the tender documents. All the O & M documents shall be supplied to INAC in two hard copies and one electronic copy.

All material shall be bound in a booklet that will allow for removal of pages with originals on white bond paper, and drawings and charts folded to fit within the booklet. The general format shall follow a typical outline including:

- Letter of Transmittal
- Index
- Introduction
- Contents
- Appendices

1.9.2 Operation and Maintenance Manual

The O & M Manual, where pertinent, shall present the information and be in the format shown below. Note that certain items such as documents supplied by manufacturers/contractors, drawings, etc. will only be available after the construction of the works.

1) System Description

a) Overview

Description of the general operation of the system as a whole. Include a schematic plan or flow chart, clearly identifying all components of the system.

b) Confined Spaces

Provide the following documents prepared by a qualified person and in accordance with the most recent version of the WorkSafeBC Occupational Health and Safety Regulation:

- A list of confined spaces;
- A written hazard assessed for each confined space or each group of confined spaces presenting similar hazards; and,
- Written entry procedures for each confined space or each group of confined spaces presenting similar hazards.

The above documents must be acceptable to the applicable health and safety regulatory agencies.

c) Collection system

Include written descriptions of the function of each component including gravity lines, force mains, pumping stations and any other part of the collection system.

d) Treatment

A written description and process flow chart of the treatment system. Include designed effluent quality, designed capacity, designed serving population and other information as necessary.

e) Effluent Disposal

Description of the method of discharge, location of the discharge, GPS coordinates, description of the receiving environment, , method of discharge and other information as necessary.

f) Solids

Type of solids, estimated quantity, solids quality, method and location of disposal, frequency of disposal and other information as necessary.

g) Permits

Copy of effluent/sludge discharge permits or regulatory requirements if any (See Policy Statements and partial list of Agencies to be contacted in Appendix VI).

2) Operation and Maintenance

a) Start-up, Operation and Maintenance Procedures

Procedures for inspecting, maintaining and servicing of all elements of the wastewater system including collection, treatment, storage and disposal of both treated effluent and sludge. Include site construction photographs or sketches which supplement or simplify the explanation of various operation and maintenance procedures. This shall include a list of equipment, servicing schedule, maintenance schedule, etc.

b) Troubleshooting

Troubleshooting instructions for facilities including pump stations, treatment facilities, and disposal facilities.

c) Emergency Response Plan

Make reference to the Emergency Response Plan document (refer to Section 1.9.4).

d) Operation and Maintenance Plan

Make reference to the Operation and Maintenance Plan document (refer to Section 1.9.3).

e) System Monitoring

Description of the monitoring and surveillance requirements, noting features and equipment included to accomplish these tasks including any automated systems, alarms and warning devices. Provide instructions on location for sampling and any necessary physical, biochemical and toxicological parameters to be tested for and frequency.

f) Effluent Quality and Receiving Environment Monitoring Program

A flow recording, influent and effluent quality and receiving environmental monitoring program shall be included and shall reflect the recommendations from the environmental assessment completed as a component of the Pre-design or Design Report (see Section 1.3.10.7) or 1.4.10).

g) Spares

Provide a list of spare equipment, tools, parts, materials, safety and hygiene equipment to be kept on hand for routine or emergency maintenance/repairs and suggested locations for storage.

h) Health & Safety

Necessary safety practices and measures including cleanliness and suggested wearing apparel.

i) Maintenance, monitoring and inspection data log templates.

3) Facility Classification and Required Operator Certification Level

Appropriate Operator Certification levels consistent with facility classification by the B.C. Environmental Operators Certification Program (EOCP) together with provisions to ensure adequate availability and replacement of certified personnel. This shall include a description of operator training requirements and a recommended schedule of operator training and certification (see also Section 1.4.7). Information regarding Facility Classification and Operator Certification is included in Appendix III.

4) Asset List

Capital asset inventory units detailing the components of the system. Complete the relevant “Capital Asset Inventory System” (CAIS) forms (available from Indian and Northern Affairs Canada) for all additions and deletions to the works. Send the forms to Chief and Council for their signature. Upon return include copies of the signed forms in the manual.

5) Documentation supplied by Manufacturer/Contractor

An assembly of manufacturer/contractor documents catalogued and indexed for ease of finding information:

- j) Material and equipment information (names, model numbers, types, sizes, certifications, warranties);
- k) Instructions and schedules for recommended O&M practices;
- l) Manufacturer’s equipment O&M manuals, commissioning procedures, signed warranty certificates, and all equipment and instrumentation set-up parameter lists;
- m) Exploded views and parts lists;

- n) Shop drawings;
- o) Suppliers' names, addresses and phone numbers;
- p) Contacts for authorized service agents.

6) Control Systems Documentation

The contractor shall provide functional descriptions, registered software and manuals, PLC and SCADA program listings and programs in electronic format.

7) Record Drawings

Include all record drawings of the wastewater collection and treatment and disposal systems, including structural, process, mechanical and electrical drawings and others as necessary. Where applicable for each lot provide a sketch with dimensions to dwellings, poles, hydrants, etc. sufficient to locate the house sewer and water services including curb and corporation stops.

8) Photos and Sketches

Site construction photographs or sketches which supplement or simplify the explanation of various Operation and Maintenance procedures.

9) Results of Commissioning

Provide the results of commissioning tests that demonstrate that the facilities are capable of meeting the design flows, and other performance criteria as appropriate. Provide a table that describes the testing, set-up and calibration activities for equipment, including but not limited to: inline water quality monitoring instruments, chemical feed pumps, flowmeters, control valves, pumps and wastewater treatment equipment. Include information about the results and dates of completion, for the testing, start-up and calibration activities.

1.9.3 **Operation and Maintenance Plan**

The Qualified Professional shall prepare a maintenance plan that incorporates, as a minimum, an O & M cost estimate, an annual work plan, and task statements. The plan shall identify the labour, equipment and material required to perform preventive and major maintenance tasks. The type and frequency of tasks shall be sufficient to ensure the health and safety of the system users and to achieve the systems designed life expectancy.

- 1) Each Task Statement/Work Order shall describe:
 - q) The location of components of the system to be maintained;

- r) The asset quantity and/or number of inventory units to be maintained;
 - s) Step by step, simple instructions of the routine and special maintenance duties;
 - t) The safe number of persons required and the equipment, tools and materials needed;
 - u) The frequency or level of service;
 - v) Estimated number of person-hours involved in each task;
 - w) Contracted services if required.
- 2) An Annual Work Plan shall be provided. A template of the "Annual Work Plan" is attached in Appendix XI for use in preparing this schedule. The Annual Work Plan shall contain a list of all inspection and preventive maintenance tasks including:
- x) Activities with work orders numbered and grouped to indicate the work required of individual people or of contractors;
 - y) Person-hours for each activity shown weekly with a summary of total hours for the year; and
 - z) Checklists to facilitate recording of maintenance done, expenses incurred and materials used for each component of the system.
- 3) A CAIS Annual Budget shall be provided to show Operation and Maintenance costs including:
- aa) For each of the maintenance tasks an estimate of the annual cost of labour, material, equipment and contracts;
 - bb) An estimate of operating costs for heat, light, fuel and/or electricity.
- 4) Reporting
- a) Routine inspection and special maintenance duties
 - b) Operation and Maintenance and monitoring data log
 - c) Operator's name, training and certification information
 - d) Proposed O & M cost estimate
 - d.1) Wages
 - d.2) Service contractors
 - d.3) Utility bills
 - d.4) Equipment fixing/replacement cost

d.5) Others

- 5) All proposed variations, additions, or deletions to the foregoing requirements shall be provided.

1.94 **Emergency Response Plan**

An Emergency Response Plan (ERP) shall be prepared if absent or updated if one exists. The INAC's First Nations Wastewater Emergency Response Plan Guide shall be followed (see Appendix VII or www.inac.gc.ca/extranet).

PART 2 – SEWERS

2.1 *DESIGN CAPACITY*

Required hydraulic capacities of sanitary sewers shall be calculated as shown in equation 2-1:

$$\text{Required Hydraulic Capacity (Peak Wet Weather Flow)} = (P) (a) (f) + C + I \quad (2-1)$$

where P = tributary population
a = average dry weather per capita flow
f = peaking factor
C = peak institutional, commercial and industrial flow
I = peak wet weather infiltration and inflow

Typically, gravity sewers less than or equal to 250 mm diameter will be designed to flow half full, and pipes 300 mm to 375 mm will be designed to flow two-thirds full. A breakdown of wastewater flows is illustrated on Figure 2-1.

Contributions from pumped flows should be based on peak pump flows, with due consideration for future increases in pumping capacity.

Allowances shall be included for peak flows associated with special events such as Potlatches and other community festivals.

2.1.1 Average Dry Weather Per Capita Flow (a)

Where no flow data are available, design flow estimates for residences can be developed by adopting a per capita average dry weather wastewater flow (a) of 320 L/c/d. This includes average base sanitary flow plus groundwater infiltration into the sewer system during dry weather. Additional minimum allowances shall be made where flow data, domestic lifestyles or site specific conditions indicate higher or lower use.

2.1.2 Peaking Factor (f)

Peaking factors (f) applied to domestic wastewater flows shall be calculated using one of the following methods:

- 1) The ratio of peak sanitary flow to average dry weather flow, where the peaking factor (f) can be estimated using equation 2-2 (see Section 4.2 for estimation of average dry weather flow)

$$f = \frac{18 + \sqrt{\frac{P}{1000}}}{4 + \sqrt{\frac{P}{1000}}} \quad \text{to a maximum of 4} \quad (2-2)$$

where P = tributary population.

- 2) or values established from valid flow studies.
- 3) or other acceptable method of establishing peak flows.

2.1.3 **Peak Wet Weather Infiltration and Inflow (I)**

The peak wet weather infiltration and inflow allowance (I) used for design shall not be less than 46 L/mm of pipe diameter/km of pipe/day. Additional allowances shall be made where flow data, or high ground water levels, etc. indicates that this is appropriate.

2.1.4 **Peak Institutional, Commercial and Industrial Flow (C)**

The peak institutional, commercial and industrial flow (C) should be determined on a case-by-case basis depending on the nature of the commercial and/or industrial activities. Table 2-1 can be used to assist in developing institutional, commercial and industrial non-residential flows. Care must be taken not to include flows that have already been accounted for as part of the residential component.

TABLE 2-1
ESTIMATED DESIGN WASTEWATER FLOWS FOR COMMERCIAL AND
INSTITUTIONAL DISCHARGES*

Type of Facility	Estimated Minimum Daily Wastewater Flow in Litres
Office No cafeteria	50 per employee
Office Including cafeteria	76 per employee
Day care centres	73 per person
Banquet and dining rooms	18 per person
Mobile home parks	1150 per space
Hospitals with laundry	750 per bed
Hospitals without laundry	550 per bed
Institutions, work camps, rest homes, residential schools	230 per bed
Nursing homes	690 per bed
Schools with cafeteria, gym & showers	68 per student
Schools with washrooms only	35 per student
Motels/hotels	320 per unit 460 per housekeeping unit
Campsites	365 per unit (seasonal operation) 545 per unit (year round operation)
Theatre (food service is limited to space single service containers)	20 per auditorium seat/car
Fixed seat assembly (theatres, churches)	10 per seat
Restaurants, dining rooms, dining lounges	90 per seat
Banquets and meeting rooms	30 per seat

* see B.C. Ministry of Health "Sewerage System Standard Practice Manual" for additional wastewater sources.

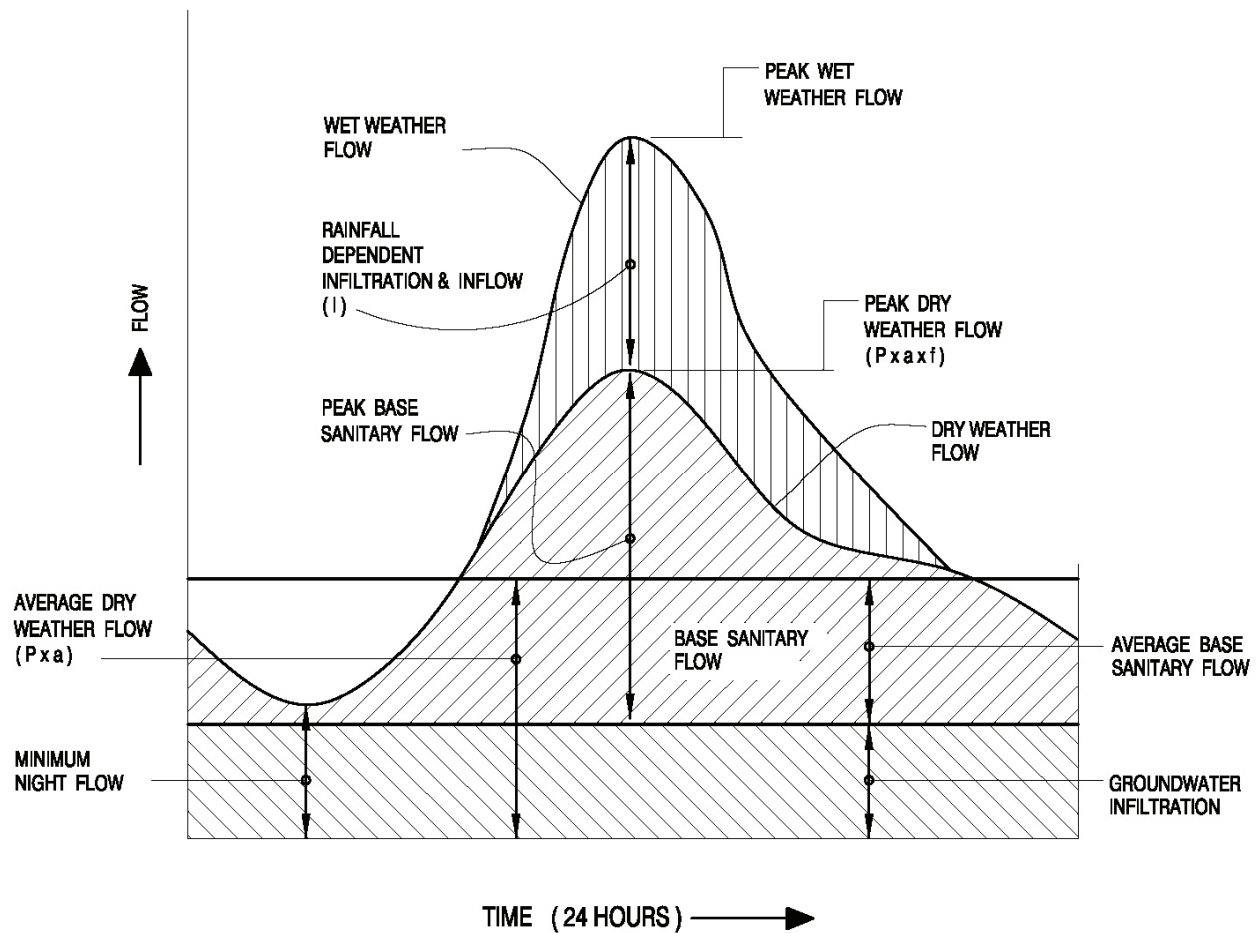

**Figure 2-1: Typical Wastewater Flow Components,
 (Excluding Institutional, Commercial and Industrial Flows)**

2.2 COMBINED SEWERS

Combined wastewater/stormwater sewers are not approved. Stormwater and run-off collectors (including roof and foundation drains) shall not be connected to the wastewater system.

2.3 DETAILS OF DESIGN AND CONSTRUCTION

2.3.1 Minimum Size

Gravity sewer(s) conveying raw wastewater shall not be less than 200 mm in diameter. 150 mm diameter for short sections may be acceptable if there is no possibility of future additional requirements, or for alternate wastewater schemes designed specifically for small communities where the growth rate is predicted to be negligible.

In general, sewers shall be sufficiently deep to receive wastewater from basements and to prevent freezing. Insulation shall be provided for sewers that cannot be placed at a depth sufficient to prevent freezing.

2.3.2 **Slope**

- 1) The flow velocity of sewers should be 0.9 m/s or greater at all points in the system when flowing full or half-full where this is feasible, but in no case shall the flow velocity be less than 0.6 m/s based on the Manning equation using an “n” value of 0.013
- 2) The flow velocity of sewers shall be 0.6 m/s or greater in all points of the system under estimated peak flow conditions when using the peaking factor from Section 2.1.2.
- 3) Calculate hydraulic manhole headlosses under estimated peak flow conditions.
- 4) Provide the following minimum sewer slopes for straight pipe sections shown in Table 2-2.

TABLE 2-2
MINIMUM SEWER SLOPES

Nominal Sewer Size	Minimum Slope in Metres Per 100 Metres
200 mm	0.40
250 mm	0.28
300 mm	0.22
350 mm	0.17
375 mm	0.15
400 mm	0.14
450 mm	0.12

- 5) Notwithstanding the above, use a minimum sewer slope of 1 percent for the first six homes serviced.
- 6) Lay sewers with uniform slopes between manholes.
- 7) Where flow velocity is equal to or greater than 3.0 m/s, design the sewer to avoid damage due to pipe or joint displacement, erosion or other effects of high velocities.

- 8) Design sewers with slopes greater than the specified minimums where possible in order to improve construction tolerances, performance under low flow and grease buildup and other similar circumstances.
- 9) Sewers on 20 percent slopes or greater shall be anchored securely with concrete anchors or equal, spaced as follows:
 - a) Not over 11.0 m centre to centre on grades 20 percent and up to 35 percent;
 - b) Not over 7.0 m centre to centre on grades 35 percent and up to 50 percent;
 - c) Not over 5.0 m centre to centre on grades 50 percent and over.

2.3.3 **Alignment**

- 1) Sewer lines shall normally be designed to follow a straight alignment between manholes.
- 2) Horizontal curves may be accepted in cases where adequate modern cleaning equipment is available. Where horizontal curves are used, the following shall apply:
 - a) The radius of a horizontal curve shall not be less than 60 m, or that radius recommended by the pipe manufacturer, whichever is greater.
 - b) Only one horizontal curve may be permitted between manholes.

2.3.4 **Changes in Pipe Size**

At all changes in pipe sizes, a manhole with appropriate benching shall be installed. When a smaller sewer joins a larger one, the invert of the larger sewer should be lowered sufficiently to maintain the same energy gradient. Typically, the crown of the pipes should be matched, and the invert of the manhole should be benching to ensure a smooth transition between the inlet and outlet pipes.

2.3.5 **Materials**

All materials shall be new and free of defects. Table 2-3 contains permitted pipe specifications for use in sewer system construction.

TABLE 2-3
PERMITTED SEWER PIPE SPECIFICATIONS

Size	Material and Class	Use	Standard
100 mm – 150 mm	cc) PVC gravity sewer pipe (locked in gasket with integral bell). Dimensional Ratio (DR) 28 or stronger ; dd) HDPE (Series 80 minimum)	Service connection	ee) CSA B182.1 ff) ASTM D3034 gg) AWWA C906
150 mm and greater	hh) PVC gravity sewer pipe (locked in gasket with integral bell). Minimum Dimensional Ratio (DR) 35; ii) HDPE (Series	Sewer main	kk) CSA B182.2 ll) ASTM D3034 green for inground identification as sewer pipe mm) AWWA C906 nn) AWWA C104 and C151

	80 minimu m); jj) Ductile Iron 1035 kPa minimu m cement mortar lined.		
75 mm and greater	oo) HDPE pp) PVC	Forcemain	qq) AWWA C906 rr) AWWA C900 ss) AWWA C905 tt) ASTM D2241

The latest edition of the above referenced standards shall apply.

Other material types may be considered for use if technically justified.

2.3.6 **Trenching, Bedding and Installation**

- 1) The class and type of pipe and fittings, together with class of bedding and trench widths shall be so selected that the pipe will support the anticipated dead and live loads while assuring pipe deflection does not exceed the manufacturers recommended deflection limits for flexible pipe materials and does not exceed the manufacturers recommended stresses for rigid pipe material. Live loads shall include H20 highway loading unless technically well justified.
- 2) Deflection tests when performed on flexible pipe shall be conducted after the final backfill has been in place at least 30 days and after service connections are installed.

- 3) No flexible pipe shall exceed a deflection of 5 percent of the as-manufactured pipe cross section.
- 4) If the deflection test is to be run using a rigid ball or mandrel, it shall have a diameter equal to 95 percent of the inside diameter of the pipe. The test shall be performed without mechanical pulling devices.

2.3.7 **Joints, Infiltration and Leakage**

- 1) The installation of joints and the materials used shall be included in the specifications. Sewer joints shall be designed to minimize infiltration and to prevent the entrance of roots throughout the life of the system. Piping shall be installed in accordance with the manufacturer’s recommendations, and for bell and spigot type pipes, the pipe shall be laid uphill with the bell ends facing uphill.
- 2) Leakage tests shall be specified. This may include the appropriate water infiltration or exfiltration tests, or low pressure air testing. The water leakage outward or inward (exfiltration or infiltration) shall not exceed 4.6 L per mm of pipe dia./km/day for any section of the system. Tests shall be conducted individually between each manhole section. An exfiltration or infiltration test shall be performed with a minimum positive head of 0.6 m. The air test, if used, shall conform to the latest edition of the test procedure described by Uni-Bell entitled “Recommended Practice for Low-Pressure Air Test – Testing of Installed Sewer Pipe”, Uni-Bell, UNI-B-6 publication. The testing methods selected shall take into consideration the range in groundwater elevations projected and the situation during the test, and must be specified by a Professional Engineer registered in British Columbia. It is recommended that leakage testing be completed prior to backfilling of pipe trenches.

2.4 **MANHOLES**

2.4.1 **Location**

The maximum distance between sanitary sewer manholes may vary according to the pipe diameters as shown below:

Pipe Size	Maximum Spacing
150 mm up to and including 375 mm	120 metres
Greater than 375 mm	160 metres

Manholes shall be provided at the following additional locations:

- 1) At all changes of grade and/or alignment;
- 2) At all changes of pipe size;
- 3) At all pipe junctions other than service connections;
- 4) Where the service connection is the same size as the main.

2.4.2 **Drop Type**

Drop manholes may be allowed only where particular circumstances preclude the use of normal manholes. These shall be constructed wherever the change in invert elevations through the manhole is greater than 0.60 m. Drops between 200 mm and 600 mm should be avoided by adjusting sewer gradients.

For drop manholes:

- 1) Preference is given to exterior drop manholes.
- 2) Exterior drop manholes to have the entire exterior drop connection encased in concrete resting on firm undisturbed soil.
- 3) Inside drop connections shall be secured to the interior wall of the manhole.

A conceptual drawing of a drop manhole is shown on Figure 2-2.

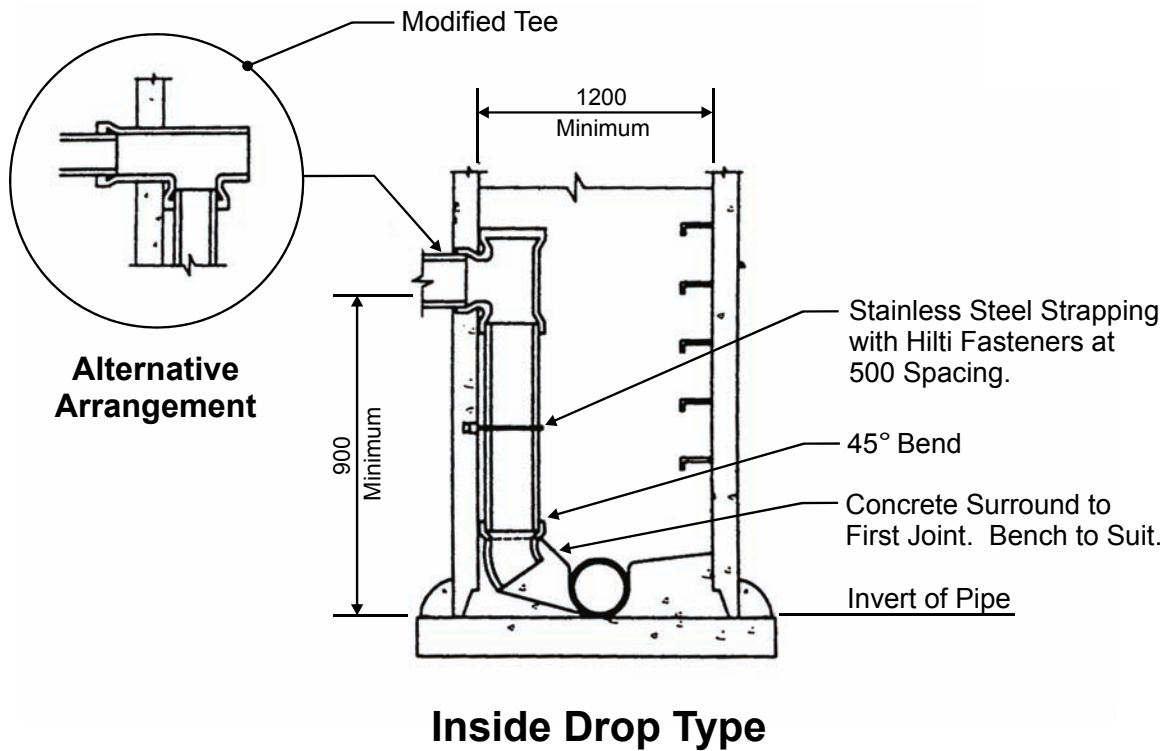
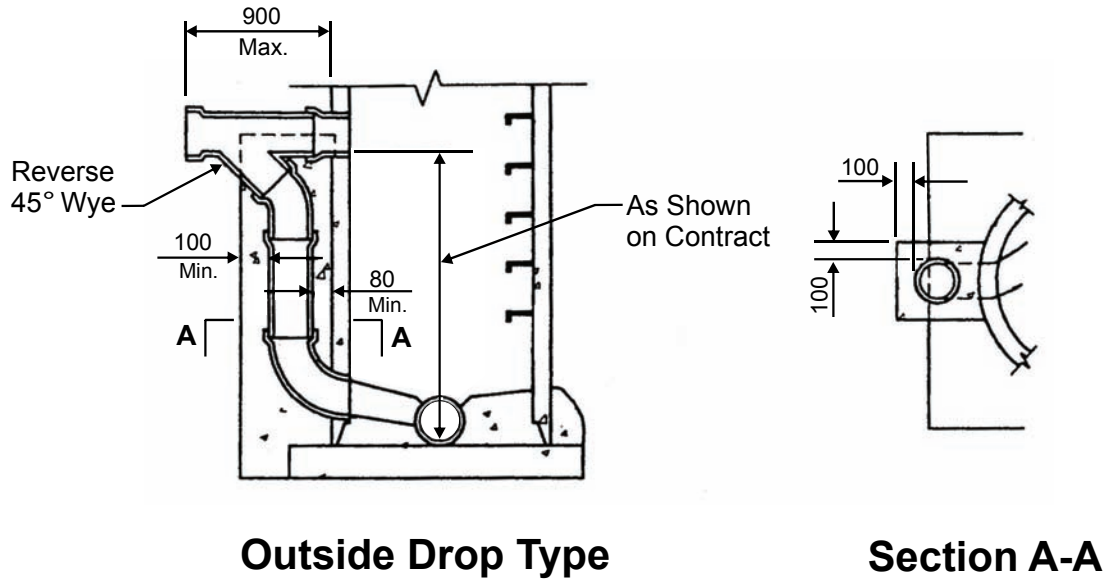

Figure 2-2: Typical Drop Manholes (from MMCD 2005)

24.3 **Flow Channel**

The relative elevations entering and leaving a manhole are to be such as to ensure that the manhole does not reduce the hydraulic capacity of the system. Allowances for energy losses or changes in velocity are to be determined in accordance with sound hydraulic principles. For 90° bends in a manhole, a 50 mm drop is normally adequate, and for straight through manholes, a 25 mm of drop is normally adequate to ensure no ponding or hydraulic restriction will occur across the manhole.

24.4 **Diameter**

The minimum diameter of manholes shall be 1050 mm. A minimum access diameter of 610 mm shall be provided.

24.5 **Manhole Stubs**

Manhole stubs shall be placed in manholes where future extensions are anticipated. The length of stubs shall be 0.60 m maximum from the outside of the manhole unless otherwise required, and the end shall be securely capped.

24.6 **Watertightness**

In the design and installation of manholes, every effort shall be made to reduce inflow and infiltration of surface water and groundwater.

Manholes shall be of the pre-cast concrete or poured-in-place concrete type.

Inlet and outlet pipes shall be joined to the manhole with flexible watertight connections that allow differential settlement of the pipe and manhole to take place.

Connect inlet and outlet PVC pipes to manhole using a manhole adaptor ring or approved equal.

Watertight manhole covers are to be used wherever the manhole tops may be flooded by street run-off or high water. Locked manhole covers may be desirable in isolated easement locations or where vandalism may be a problem.

Completed manholes shall be tested for leakage by filling manhole up to top with water and allow to stand for 24 hours. Then refill manhole to top and monitor liquid drop over 2 hours. No measurable drop in level over 2 hours will constitute an acceptance of the manhole leakage test.

24.7 **Prevention of Gravel and Grit Ingress**

To prevent the ingress of gravel and grit into manholes, locating sewer lines and manholes out of the gravel road beds shall be considered. If manholes are located in

the gravel roads, bolts with washers and nuts shall be installed in the covers when watertight covers are not used.

2.5 INVERTED SIPHONS

In general, inverted siphons should be avoided. Where necessary, inverted siphons shall have not less than 2 barrels, with a minimum pipe size of 150 mm. The siphon shall be provided with necessary appurtenances for convenient flushing and maintenance. The siphon inlet and outlet chambers shall have adequate clearances for rodding; and in general, sufficient head shall be provided and pipe sizes selected to ensure velocities of at least 0.92 m/s under average flows are achieved. The inlet and outlet details shall be so arranged that the flow can be diverted to 1 barrel, and that either barrel may be taken out of service for cleaning.

The vertical alignment shall permit cleaning and maintenance.

2.6 SEWERS CROSSING OR ADJACENT TO STREAMS

2.6.1 Location of Sewers on Streams

1) Federal and Provincial Agencies Approvals

Federal and Provincial agencies having jurisdiction over aspects of streams and rivers must be contacted and approval and permits received for proposed works in or adjacent to streams. Such permits may specify design and construction methods, schedules and may include requirements for environmental monitoring, mitigation and compensation. See Appendix VI for partial list of Agencies to be contacted.

2) Cover Depth

The top of all sewers entering or crossing streams shall be at a sufficient depth below the natural bottom of the stream bed to protect the sewer line. In general the following cover requirements must be met:

- a) 300 mm of cover is required where the sewer is located in rock.
- b) 900 mm of cover is required in other material. In major streams, more than 900 mm of cover may be required.
- c) In paved stream channels, the top of the sewer line should be placed at least 300 mm below the bottom of the channel pavement.

Less cover will be accepted only if the proposed sewer crossing will not interfere with future improvements to the stream channel. Reasons for requesting less cover shall be given in the project proposal. It is the Qualified Professional's responsibility to determine the need of a hydrologist to review river bottom scour potential and determine additional cover or protection measures. Involvement of a hydrologist may be required.

3) Horizontal Location

Sewers located adjacent to streams shall be located outside of the stream bed and sufficiently removed there from to provide for future possible stream widening and to prevent pollution by siltation during construction.

4) Structures

The sewer outfalls, headwalls, manholes, gate boxes, or other structures shall be located so they do not interfere with the free discharge of flood flows of the stream.

5) Alignment

Sewers crossing streams shall be designed to cross the stream as nearly perpendicular to the stream flow as possible and shall be free from change in grade. Sewer systems shall be designed to minimize the number of stream crossings.

2.6.2 **Construction**

1) Materials

Sewers entering or crossing streams shall be constructed of ductile iron pipe with "Lok-Tyton" joints; they shall be constructed so they will remain watertight and free from changes in alignment or grade. Material used to backfill the trench shall be stone, coarse aggregate, washed gravel, or other materials which will not cause siltation.

2) Siltation and Erosion

Construction methods that will minimize siltation and erosion shall be employed. The Qualified Professional shall include in the project specifications the method(s) to be employed in the construction of sewers in or near streams to provide adequate control of siltation and erosion. Specifications shall require that cleanup, grading, seeding, and planting or restoration of all work areas shall begin immediately. Exposed areas shall not remain unprotected for more than seven days.

2.7 AERIAL CROSSINGS

Support shall be provided for all joints in pipes utilized for aerial crossings. The supports shall be designed to prevent frost heave, overturning and settlement.

Precautions against freezing, such as insulation and increased slope, shall be provided. Expansion jointing shall be provided between above-ground and below-ground sewers.

For aerial stream crossings, the impact of flood waters and debris shall be considered. The bottom of the pipe should be placed no lower than the elevation of the one in 200-year flood return frequency, plus at least 600 mm freeboard allowance. Other factors (e.g., ice build-up and stream use, such as boating) may require much higher clearances to ground or stream surfaces.

2.8 PROTECTION OF WATER SUPPLIES

(Refer also to Design Guidelines for Water Works in B.C. Region)

2.8.1 Water Supply Interconnections

There shall be no physical connection which would permit the passage of any wastewater or polluted water into the potable supply. No water pipe shall pass through, or come in contact with, any part of a sewer manhole.

2.8.2 Relation to Water Works Structure

While no general statement can be made to cover all conditions, it is generally recognized that sewers shall meet INAC's requirements with respect to minimum distances from public water supply wells or other water supply sources and structures.

2.8.3 Separation of Watermains, Sanitary Sewers, and Storm Sewers

1) General

The following factors shall be considered in providing adequate separation:

- a) Materials and type of joints for water and sewer pipes;
- b) Soil conditions;
- c) Service and branch connection into the watermain and sewer line;
- d) Compensating variations in the horizontal and vertical separations;
- e) Space for repair and alterations of water and sewer pipes; and
- f) Off-setting of pipes around manholes.

2) Parallel Installation

Gravity sewers and wastewater forcemains shall be laid with at least 3.3 m horizontal separation from any existing or proposed watermain. The distance shall be measured between near side edges of the pipes. In cases where it is not practical to maintain a 3.3 m separation, deviation may be allowed on a case-by-case basis, if supported through explanation for the necessity and by data. Such deviation may allow installation of the sewer closer to a watermain, provided that the watermain is laid in a separate trench or on an undisturbed earth shelf located on one side of the sewer and at an elevation such that the bottom of the watermain is at least 450 mm above the top of the sewer, and the near side edges of the pipes are a minimum of 300 mm apart. Sealing of the pipe joints using tape wrap or heat shrink sleeves may also be required.

3) Crossings

Gravity sewers and wastewater forcemains shall cross under watermains and shall be laid to provide a minimum vertical distance of 450 mm between the near side edges of the water and sewer mains. The crossing shall be arranged so that the sewer joints will be equidistant and as far as possible from the water main joints. Where a watermain crosses over a sewer, adequate structural support shall be provided for the sewer to prevent damage to either pipe.

4) Special Conditions and Variances

When it is impossible to obtain the specified separation distances, justification must be provided for any variance from the requirements of the above sections.

When it is impossible to obtain proper horizontal and vertical separation as stipulated above, the sewer shall be designed and constructed equal to watermain standards, and shall be pressure tested in place to 100 kPa to assure watertightness prior to backfilling.

In rock trenches, facilities shall be provided to permit drainage of the trench to minimize the effects of impounding of surface water and/or leakage from sewers in the trench. When significant rock blasting is required for the lot services, a common trench for water and sewer services may be considered but must meet the requirements noted above.

2.9 SERVICE CONNECTIONS

2.9.1 Definitions

1) House or Building Drain

This is the pipe extending from the interior plumbing of the building to a point at least 0.9 m outside the foundation wall.

2) Sanitary Service Connection

This is the pipe connecting the house or building drain to the septic tank (or other treatment device) or to the sewer main.

3) General

- a) Service connections shall meet the requirements of the Canadian Plumbing Code.
- b) Service connection materials and installation shall be in accordance with Sections 2.3.5 Materials and 2.3.6 Trenching, Bedding and Installation, respectively. A minimum slope of 2 percent shall be provided.
- c) Service connections shall be provided with cleanouts that will permit cleaning of the entire system. The location and number of cleanouts shall be in accordance with the Canadian Plumbing Code.
- d) A minimum horizontal separation of 3.3 metres shall be provided between a service connection and any water line. Suction lines from wells shall not cross the service connection.
- e) Roof drains and building perimeter drains shall not be connected to the sanitary sewer.

PART 3 – WASTEWATER PUMPING STATIONS

3.1 INTRODUCTION

The design guidelines included in this section are a general outline of criteria for a typical submersible duplex wastewater pumping station. The guidelines apply to duplex pumping stations with a design capacity of up to 1,000 people (300 dwelling units). All stations shall be designed to meet maximum flow conditions with the largest pump in a failure mode. Larger capacity wastewater pumping stations or pumping stations with special design or siting requirements will require additional assessment and review of criteria. All wastewater pumping stations shall be designed by a professional engineer licensed in the specific discipline.

Wastewater pumping stations are expensive to construct, maintain and operate. Efforts shall be taken to minimize the number of pumping stations required and to thoroughly consider other options to avoid pumping stations. If a pumping station is unavoidable, then an installation which satisfies environmental, health, and safety aspects and avoids unnecessary complexity of operation and maintenance in the most cost effective manner shall be designed.

A factory built pumping station which meets these guidelines and is built by an experienced manufacturer, capable of offering a service and maintenance program from factory trained technicians, is preferred. A typical wastewater pumping station is shown on Figure 3-1.

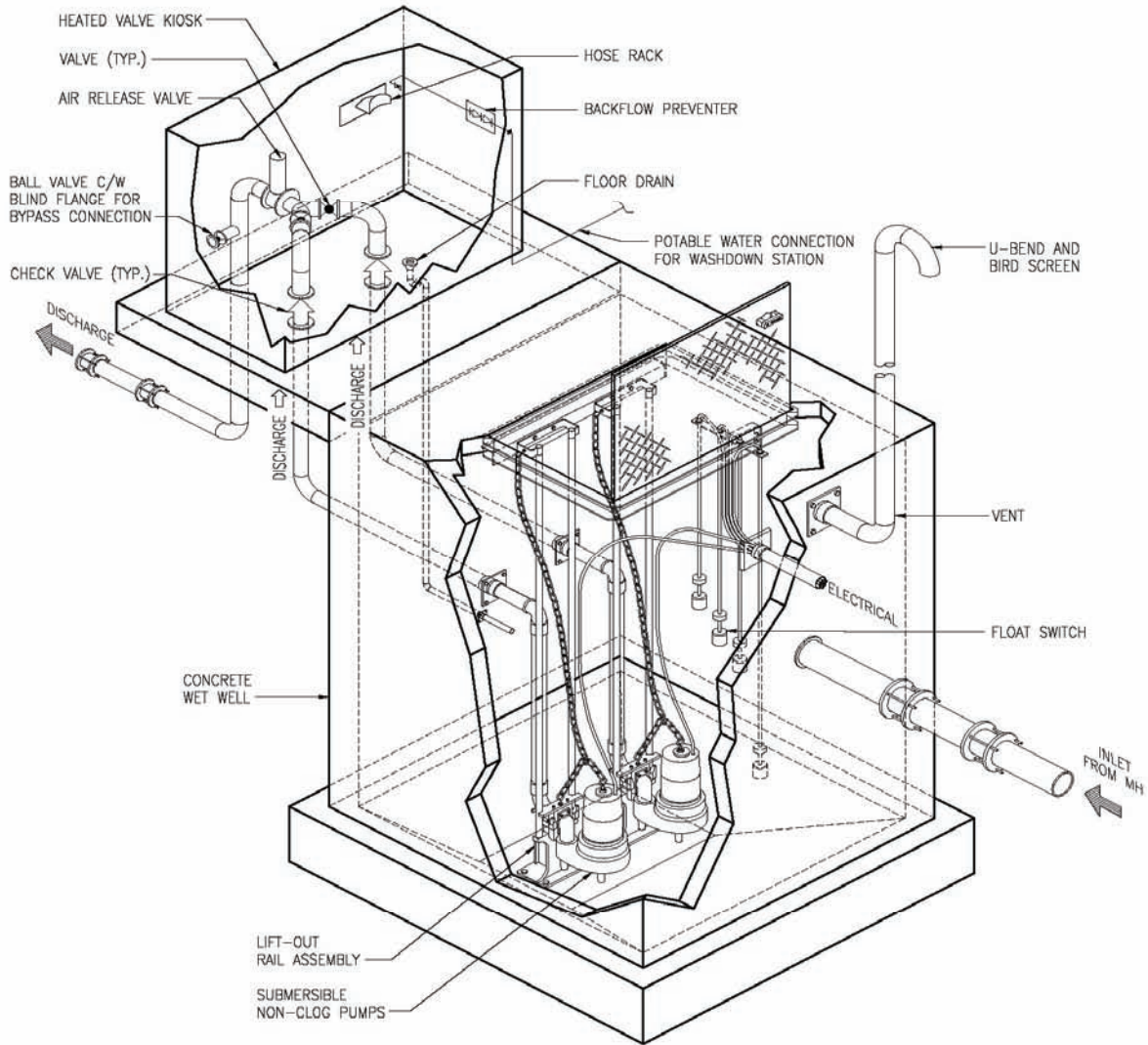

Figure 3-1: Typical Wastewater Pumping Station

3.2 LOCATION AND LAYOUT

The location and layout of the pumping station shall include an assessment of the following basic design considerations.

3.2.1 Service Area

The pumping station shall be designed to handle flows from the entire area to be serviced for present and future development.

3.2.2 Gravity Flow

The pumping station shall be low enough and of sufficient capacity to avoid additional pumping stations or expensive reconstruction for future development. Energy requirements shall be minimized by keeping required pumping lift to a minimum.

3.2.3 Excavation

The parameters that affect the length of time the excavation is open, such as the soil conditions and excavation stability and type of barrel material (pre-fabricated or constructed on-site), shall be considered.

3.2.4 Aesthetics

Aesthetics, such as noise, odour and appearances, which may impact on nearby residents, and preference of neighbours and the community as a whole.

3.2.5 Dewatering

Construction dewatering requirements, including foundation stability of neighbouring structures and cost of construction.

3.2.6 Flood Elevations

Flood Elevations - structural aspects of wastewater pumping stations and the electrical and mechanical equipment shall be protected from physical damage by the 1 in 200-year flood – wastewater pumping stations shall remain fully operational and accessible during the 1 in 25-year flood – station entrance elevation and access route to station shall consider the 1 in 200-year flood levels – pumping station uplift design shall be based on the 1 in 200-year flood level with no wastewater in the station.

3.2.7 **Access**

Access for construction and its effects on the costs – the pumping station shall be readily accessible by maintenance vehicles during all seasonal weather conditions – the facility shall be located off the traffic way of streets and alleys.

3.2.8 **Security**

Potential for vandalism, theft and injury and the necessary security requirements, such as fencing or need for a more visible location.

3.2.9 **Utilities**

Proximity of sewers, watermains and power supply as they relate to cost of developing alternative sites.

3.2.10 **Site Power**

Power supply voltage, phase and impact on power utility – such considerations may determine such aspects as whether power failure delay timers and/or reduced voltage starting are required.

3.2.11 **Standby Power**

Use of standby power or alternate provisions (such as pump-out tank truck) during power outages and availability and response times of back-up equipment for pumping station shall be determined.

3.2.12 **Soil Investigations**

Soil subsurface investigations shall be undertaken to reveal site conditions prior to acceptance – a minimum level of investigation shall be a test hole augered or excavated by backhoe.

3.2.13 **Features**

Convenience features, reliability, and complexities with respect to operation and maintenance activities shall be considered.

3.2.14 **Safety**

Safety features such as reducing the need to enter the station and improving access to items requiring service or adjustment.

3.2.15 **Costs**

Life cycle costs (capital and O & M) in deciding on design features – additional capital expenditure may be offset by lower O & M costs over the life of the station or may be required to reduce O & M complexities to an acceptable level.

3.3 ***INFLUENT STRUCTURES AND FORCEMAIN***

3.3.1 **Influent Pipe**

To facilitate the control of entrance velocities, the isolation of the pump station, the installation of the debris basket (if used), the maintenance of uniform flow patterns, etc., only one influent pipe shall enter the wet well.

3.3.2 **Influent Manhole**

An inlet manhole shall be used for the junction of pipes, for flow pattern and velocity control as well as to provide a sump for a portable pump for emergency bypassing of the pump station. The manhole shall be located a distance from the station to ensure that its foundation is not affected by the pump station excavation and provide sufficient room for valve and flexible couplings.

3.3.3 **Influent Velocity**

Wet well influent pipe entrance velocities shall be maximum 1.5 metres per second to reduce tendency for vortexing, minimize movement of float switches, etc.

3.3.4 **Air Entrapment**

Conditions that would introduce air into the pumps shall be avoided (e.g. drop distance over one metre and entrance configuration). Consider using drop connection and directing inflow away from pump base.

3.3.5 **Flow Patterns**

Uniform flow patterns to each pump shall be maintained to prevent vortex formation and solids buildup.

3.3.6 **Debris Management**

Provision of an open topped debris basket at the inlet may be considered after discussions with the Band's operations representatives. Where clogging of pumps is a concern, the use of recessed impeller pumps may be sufficient – see Section 3.4.2 (5). Recessed impeller pumps are well suited for handling large solids as the impeller vanes only extend partially into the casing, essentially leaving the casing as an open flow passage. Public health implications, such as handling and disposal of

solids, must be considered and discussed with the operations personnel. Where used, the debris basket shall be designed using 10 mm round bars at 60 mm c/c. A minimum 40 mm diameter galvanized lifting chain from the debris basket shall be utilized and the lifting chain shall be compatible with the chain hoist. Access hatch and guide rails for the debris basket (if used) shall be installed in the original construction to accommodate future installation of the debris basket if not installed initially.

3.3.7 **Valves**

An AWWA resilient seat, ductile iron gate valve with a Nelson type valve box and stem extension between the pumping station and first inlet manhole shall be provided.

3.3.8 **Couplings**

Two flexible couplings (Dresser type) on all pipes entering and leaving station shall be provided to allow for differential settlement between the pump station and pipes. Locate one coupling 300 mm and the other 2.0 m from the station.

3.3.9 **Forcemains**

See Section 3.10 for forcemain design requirements.

3.3.10 **Alarms**

Pumping stations shall be equipped with high liquid level and equipment failure alarms.

3.4 SUBMERSIBLE PUMPS AND STATIONS

Submersible pump stations shall be designed to minimize the need for maintenance personnel to enter the wet well with the associated confined space entry concerns. Pump station design shall consider above grade valve chambers. All pump station materials within the wet well shall be highly corrosion resistant, for example stainless steel, epoxy coated steel or fibre reinforced plastic or plastic are several proven material types. Pump stations serving fewer than five homes may contain a single pump, provided that spare replacement pumps (minimum one pump per three pump stations) are kept on hand.



Submersible Pump Station

For systems serving five or more homes, a submersible pump station consists of a wet well, a minimum of two submersible pumps, piping train, pump controls and power supply, and shall meet the following design guidelines.

3.4.1 **General**

1) Washdown system

A system for washing down the pump station shall be available to facilitate proper maintenance. The Qualified Professional must satisfy him/herself that the method is technically and operationally sound. The relevant technical and operational aspects must be detailed in the Pre-design Report and summarized in the Operation and Maintenance Documents.

The type and integrity of the pump station washdown system shall prevent water contamination through cross connection. Acceptable systems are as follows:

- a) A minimum 50 mm self draining standpipe supply within 10 metres of the station, including provision of a minimum of 20 metres of 50 mm fire hose with model HNL4 plastic type nozzle. Valves and fittings to connect to the standpipe shall be provided. The standpipe outlet must not be in danger of being flooded with contaminated water.

Cross connection protection through use of a reduced pressure principle backflow prevention device. The device must be isolated by gate valves meeting AWWA specifications. The device must be designed and installed in strict accordance with the latest edition of AWWA M14 manual titled "Recommended Practice for Backflow Prevention and Cross-Connection Control."

Consideration for testing and repair of the backflow prevention device at least once per year by a person certified by the BCWWA. Details on this item (such as name and address of certified tester, provision of second unit for use during removal and repair of first unit, Band Council by-law, etc.) shall be included in the Operation and Maintenance Manual and Plan.

A sign on inside of the pump station hatch as follows: "WARNING - POTENTIAL HEALTH HAZARD TO COMMUNITY - DO NOT PLACE WASHDOWN HOSE IN WET WELL".

- b) Pumper truck or a fire truck capable of hauling a minimum of 2300 litres of clean water and providing a minimum residual pressure of 240 kPa. (Use of the fire truck for this purpose shall be under the direction of the community's fire chief.)

2) Pumping Station Enclosure

The kiosk and pumping station shall be enclosed with a 1.8 m high galvanized chain link fence. The enclosure shall include a 900 mm wide main gate with padlock hasp. Where no fence is required, guard posts shall be provided. Warning signs must be posted on all sides of the fence to advise of the danger within the fenced area.

3) Storage Facilities

Secure storage facilities for all spare and ancillary equipment shall be provided and the equipment list and storage location shall be specified in the Operation and Maintenance Documents.

3.4.2 Pumps

- 1) Each pump shall meet worst flow conditions (i.e. maximum influent flow, HWL at discharge point, LWL in wet well, worst "C" value and with the other pump in failure mode). A third spare replacement pump, with the manufacturer's instructions on proper storage methodology, shall be provided with the station.
- 2) At no point on the pump's system curve shall the pump operate within the motor service factor.
- 3) Under automatic control, pumps shall operate alternately to ensure even wear on pumps and provide a longer cycle time.
- 4) The pumps shall be equipped with seal leak probe and motor heat sensor only if required by the manufacturer/supplier of the pumps. There shall be control panel mounted alarm light indications for the probes and sensors.
- 5) Pumps shall have non-clog channel or recessed impellers that will pass minimum 60 mm spherical solids, or grinder pumps as noted in Item (6).
- 6) Grinder pumps require additional maintenance and attention and therefore are not a preferred option. Grinder pumps may be considered where the design peak flows do not exceed 3 L/sec. The performance of grinder pumps having three phase motors is significantly better than those with single phase motors.
- 7) The pumps and controls of pumping stations, and especially pump stations pumping to the treatment works or operated as part of the treatment works, shall be selected to permit discharging wastewater at approximately the peak rate of delivery to the pump station. It is important to note that oversized pumps can overload downstream facilities and can disrupt treatment processes. Variable speed pumps are recommended if high variations associated with simple on/off operation will negatively impact downstream facilities and processes. This will enable the pumps to be run at a lower flow rate and limit slugs of wastewater that may result from oversized pumps operated in on/off configuration. Design

of variable speed pumps shall include features to achieve self-cleansing velocities in forcemains at least once every 24 hours. Variable speed pumps may not be suitable for certain applications, such as dosing ground disposal fields.

- 8) The maximum number of starts per hour shall be as recommended by the pump manufacturer (this information shall be included in the O & M Manual, see section 1.9.2). The minimum wet well volume shall be designed to meet this requirement. Typically 6 starts per hour with one pump in service, will be used to size the wet well.



Inside of Pump Station

3.4.3 **Wet Wells**

- 1) A pump discharge connection elbow with guide bars made of hot dipped galvanized or stainless steel pipe for quick removal of the pump shall be provided. The guide bars shall be installed as a pair running from the discharge connection to an upper guide bracket attached to an access frame on top of the station. The pumps shall have a lifting chain that is compatible with the pump hoist.
- 2) Proper spacing of the pumps shall be provided (refer to manufacturer's recommendations). Other standards for the wet well design, such as Hydraulic

Institute standards shall be used as required to ensure the pumps do not vortex, cavitate, and that dead areas within the wet well are eliminated.

- 3) The wet well bottom corner shall be filleted to direct flow toward pump suction and to minimize solids build up. Preferably the fillets should have a slope of 60 degrees from the horizontal (minimum slope of 30 degrees) and extend to within 200 mm of the suction centre if possible.
- 4) The design of the wet well and pump station shall receive special consideration to avoid operational problems from the accumulation of grit.
- 5) Adequately sized and located access frames with hatch covers (min. 500 x 600 mm) for access and for removal of pumps and strainer baskets, shall be provided. The access covers should be stainless steel, aluminum or fiberglass for corrosion resistance (reduced maintenance). Access covers shall have recessed padlock hasps, with a box enclosure to prevent vandalizing of lock, and suitable brass padlocks. Where possible, factory standard hatches shall be used, complete with stainless steel trim, and spring or air piston assist mechanisms.
- 6) Ventilation of the wet well shall be provided. See Section 3.6.5.
- 7) Supports for level control system, pump lifting chain, power cable and debris basket lifting chain shall be accessible by reaching from ground level and without entering the wet well.
- 8) Reinforced concrete or fiberglass barrel for the pumping station wet well shall be used. All barrels shall be reinforced for the soil and 200-year flood loadings with the station empty.
- 9) The minimum pumping station diameter shall generally be 2400 mm to provide adequate room for installation and maintenance of required equipment and to provide sufficient storage to limit pump cycling. Small systems serving a small number of houses may be 1800 mm in diameter.
- 10) The low water level (pump shut-off) shall take into consideration the minimum submergence depth recommended by pump manufacturer that would prevent vortexing and provide motor cooling. The minimum pumping volume shall be measured above this low water level.
- 11) An aluminum or stainless steel ladder for access to wet well shall be provided. When the ladder is over 6 metres long, a ladder safety climbing device complete with safety belt, fixed safety cable clamp, 10 mm diameter galvanized aircraft steel cable unit, with tensioning spring and climbing extension, shall be provided. The cable shall be located in the centre on the front face of the ladder. For deep stations where ladders are longer than 6 m, safety platform options are not favoured because of difficult maintenance conditions. The safety platform could encourage people to enter the station where design emphasis is a layout that will not require entering the station for operation and maintenance.

12) In deep stations (over 6 metres), an intermediate guide bar support and a power cable strain relief connector shall be provided.

13) An explosion proof light shall be provided as detailed in Section 3.6.6.

3.4.4 **Pipes and Valves**

- 1) A connection between the check valve and isolating valve for standby pumping, complete with blind flange and gasket, shall be provided to allow pumping to the forcemain with auxiliary engine driven pump as backup in the event of power and/or mechanical failures of pumps and/or controls. This riser pipe also allows insertion of a "pig" to clean the forcemain if required.
- 2) A 90 degree elbow shall be installed to align the riser blind flange horizontally to facilitate the hose connection. If freezing is expected to be a problem, provide an insulated box to cover the riser pipe in the winter. Alternatively, provide a tapped bleed hole, complete with threaded plug fixed to a chain that is welded to the pipe, and an isolating plug valve located near the top of the riser pipe or provide suitable explosion-proof thermostatically controlled heater and fan for pumping station.
- 3) Valves shall be located outside of pumping station wet wells. Outside lever and weighted check valve, or a rubber flapper type check valve or a ball check valve and resilient seated eccentric plug valve for each pump shall be provided. Requirements for excessive hydraulic transients shall be considered.
- 4) Where valves are located inside pumping station wet wells, a valve maintenance platform extending from the proximity of the check and gate valves to the ladder rungs shall be provided to facilitate maintenance activities on the valves. This platform shall be lightweight and be able to fold upwards so as not to obstruct washdown and other maintenance activities taking place from outside the station. The platform shall be located at such height to facilitate all possible maintenance activities on the valves.

3.4.5 **Lifting Device**

Support for a lifting device attached to or located adjacent to the station structure shall be provided. The lifting device shall include the following items:

- c) removable lifting davit capable of swinging 360 degrees in a horizontal plane;
- d) chain hoist;
- e) platform socket or wall mounted socket; and
- f) load chain.

The lifting chains for the pumps and debris basket shall be compatible with the chain hoist. The hoist shall be permanently fixed (welded) to the davit to prevent loss.

3.5 METHODS OF OVERFLOW PREVENTION

As stated in Policy Statement #7, overflows of untreated or partially treated wastewater is not allowed. Methods to consider for overflow prevention include one or more combinations of the following:

3.5.1 Storage

Storage capacity, including storage capacity in trunk sewers and storage basins, shall be designed to drain back into the wet well or collection system.

3.5.2 Infiltration Basin

Emergency infiltration basin sized with allowance for precipitation (requires hydrogeological impact study).

3.5.3 Standby Pump

An in-place or portable pump, driven by an internal combustion engine, which meets the requirements of Section 3.5.4, capable of pumping from the wet well to the discharge side of the station.

- 1) Engine-driven pump(s) shall meet the design pumping requirements unless storage capacity is available for flows in excess of pump capacity.
- 2) Pumps shall be designed for anticipated operating conditions, including suction lift requirements.
- 3) The engine and pump shall be equipped to provide automatic start-up and operation of pumping equipment. Provisions shall also be made for manual start-up. Where manual start-up and operations are justified, storage capacity and the alarm system must meet the requirements of Section 3.5.4.

3.5.4 Engine Driven Generators

Where permanently installed or portable engine-driven generating equipment is used, the following requirements in addition to requirements outlined elsewhere shall apply.

- 1) Generating unit size shall be adequate to provide power for pump motor starting current and for lighting, ventilation, and other auxiliary equipment necessary for safety and proper operation of the pumping station. In the case of multiple pumping units, special sequencing controls shall be provided to start pump motors unless the generating equipment has capacity to start all pumps simultaneously with auxiliary equipment operating.

- 2) Provisions for automatic and manual start-up and load transfer shall be made. The generator must be protected from operating conditions that would result in damage to the equipment. Provisions to allow the engine to start and stabilize at operating speed before assuming the load shall be considered. Where manual start-up and transfer is justified, storage capacity and alarm systems shall meet the requirements of Section 3.8.
- 3) Where part or all of the engine-driven pumping equipment is portable, and/or where there is manual load transfer equipment, sufficient storage capacity shall be provided to allow time for detection of pump station failure, and for transportation and hookup of the portable equipment. A riser from the forcemain with a quick-connect coupling and appropriate valving shall be provided for connection of the portable pumps. The use of special connections, configured for safety and BC Hydro approved double throw switches is recommended for connecting portable generating equipment.

3.6 ELECTRICAL DESIGN

3.6.1 Equipment

All equipment shall be CSA approved and of suitable quality for this application and shall be warranted for one (1) year from commencement of operation.

3.6.2 Design

All electrical designs and installations shall be to the satisfaction of the Provincial Electrical Inspector and B.C. Hydro. All electrical design shall be sealed by a Professional Engineer registered in British Columbia.

3.6.3 Wiring

- 1) All wiring shall be copper.
- 2) For raw wastewater stations, all interior wiring in the wet well shall be explosion proof, Class I, Zone 2, Group D, as required by the Provincial Electrical Inspector. For septic tank effluent pump stations, all interior wiring in the wet well shall be explosion proof, Class I, Zone 1, Group D, as required by the B.C. Provincial Electrical Inspector.

3.6.4 Kiosk

- 1) The control panel shall be mounted in a suitable kiosk. The kiosk shall be installed on a concrete pad such that the components are kept away from pumping station access hatches and away from the pump lifting device. A pedestal mounted kiosk can be considered on a site-specific basis and, if proposed, its use shall be substantiated on a technical, operation and

maintenance basis. Location of the access doors on one side of the kiosk is preferred. A typical pump station electrical kiosk is shown on Figure 3-2, and a typical control panel layout is shown on Figure 3-3.

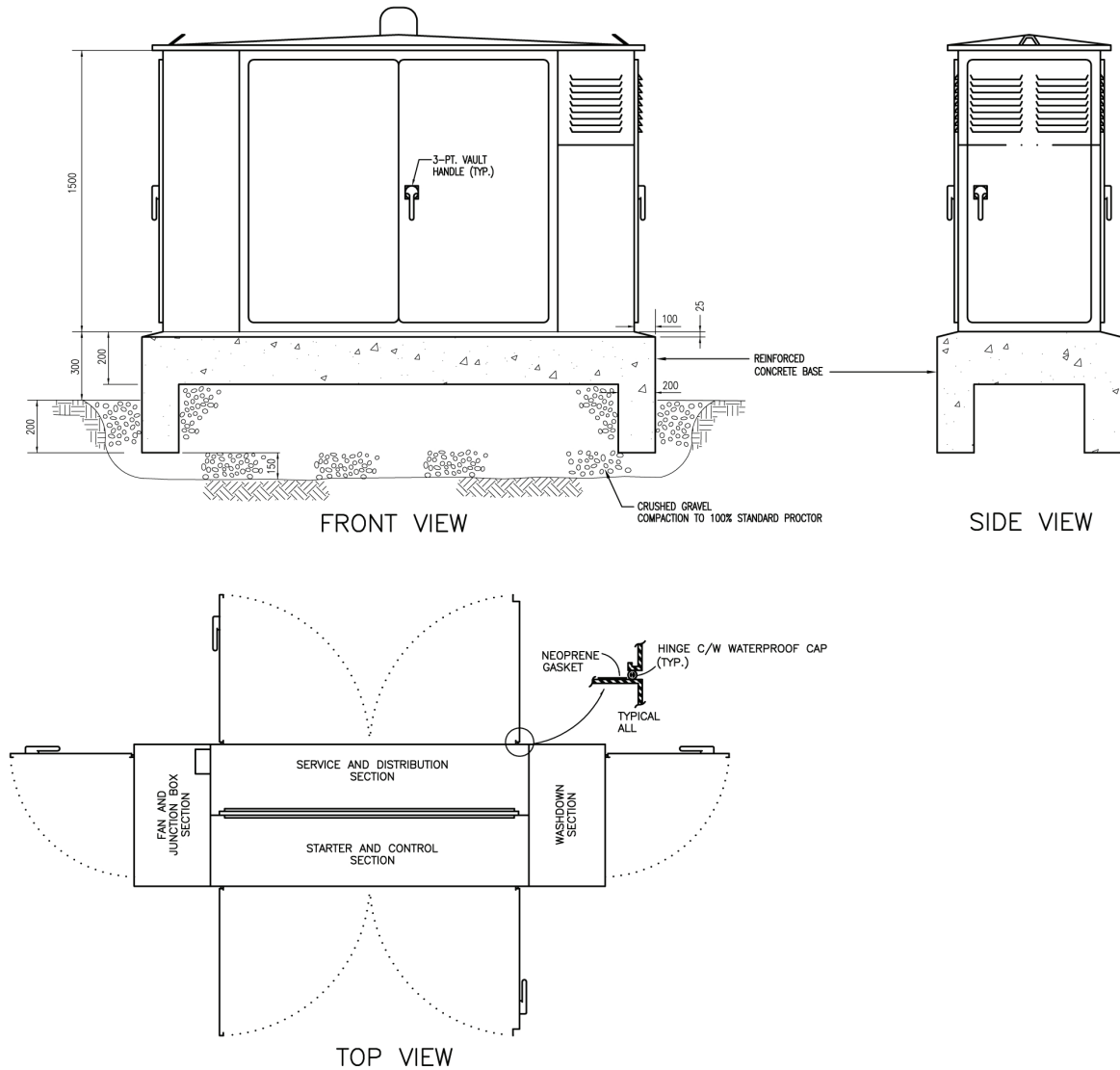

Figure 3-2: Typical Pump Station Electrical Kiosk Layout

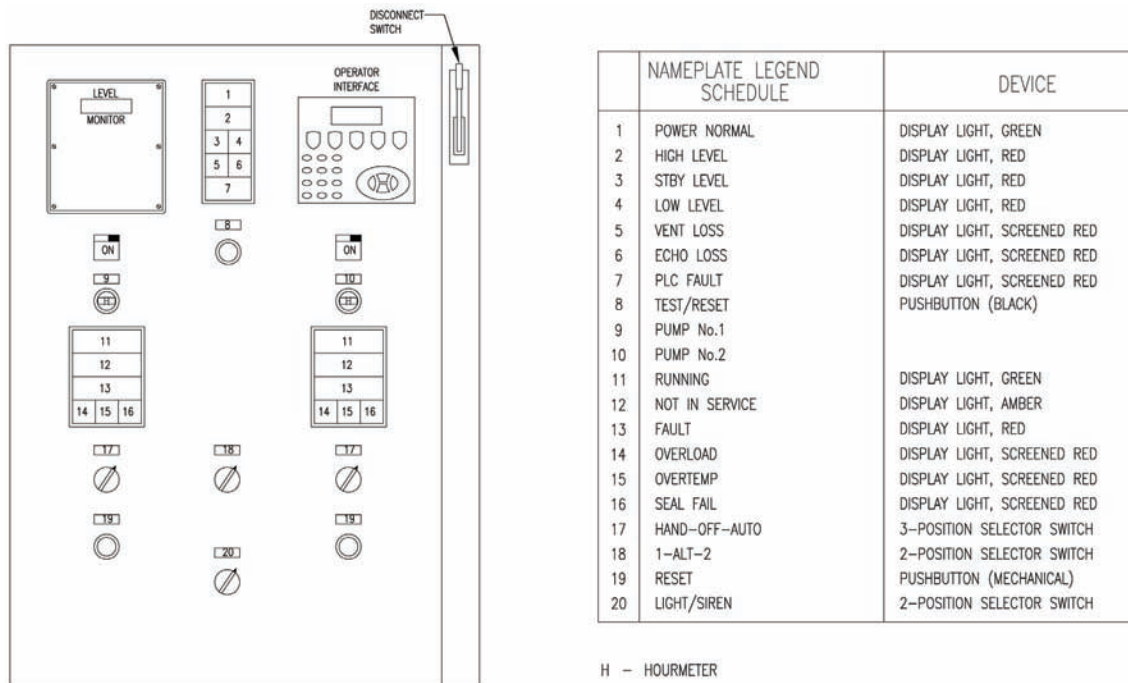

Figure 3-3: Typical Pump Station Control Panel Layout

- 2) The kiosk enclosure shall be EEMAC Type 3 (weather proof) construction mounted on a concrete pad. The kiosk shall be minimum 12 gauge steel, have fully gasketed doors, be finished in ANSI transformer green enamel, and have minimum dimensions of 600 mm deep, 1200 mm wide, 1800 mm high with double lockable doors on one 1200 mm x 1800 mm side and a suitable brass padlock. The metal base of the kiosk shall raise the bottom of the doors at least 300 mm above the concrete pad and higher where snow depth dictates. Controls and meters shall be at a level suitable for operation from ground elevation (i.e. at eye level). The kiosk shall provide room for all electrical components including the fan.
- 3) The metal base of the kiosk shall have a sealed enclosure for the supply fan with a removal access panel and an inlet louvre located at least 900 mm above the concrete pad or higher as dictated by the maximum snow depth.
- 4) The control panel shall have a thermostatically controlled heater installed in the control compartment to prevent a moisture problem in the electrical controls. The heater shall be a 500 watt single phase heavy duty baseboard heater with white powder coat finish, stainless steel element and integral thermostat, suitable for 120 VAC.
- 5) A power inlet receptacle on the kiosk wall and approved transfer switch suitable for connecting standby power shall be provided to facilitate quick plug-in of an engine driven generator. Non-conducting materials shall be used for receptacle and plug units. A matching plug and suitable generator shall be made available. The required generator KW (KVA) power output needed to operate the pumps

shall be specified on a "lamicoid" plate, mounted adjacent to the receptacle, to help ensure that an adequate power generator is brought to the site in an emergency.

- 6) Controls for pumps and alarm systems shall be placed in one compact unit in the kiosk to provide the best arrangement for organizing and protecting the electrical system. The pump control panel, meter base, service circuit breaker, ventilation fan, transfer switch and standby receptacle, and other electrical components shall be mounted within a suitable kiosk to provide secure location. The wet well ventilation fan shall be mounted in a separate compartment in the kiosk that is isolated from ignition sources. The backflow preventer and washdown hose may also be included within a separate kiosk compartment.
- 7) The kiosk shall include:
 - a) Extra duplex receptacle for small tools with ground fault circuit interrupter.
 - b) A non-metallic 100 A, 3-wire, 4-pole power inlet receptacle with reverse contacts so that pins are not live (e.g. Crouse-Hinds CH4100B5W), and BC Hydro approved double-throw-non-fusible manual transfer switch for standby power. The required generator KW (KVA) power output needed to operate the pumps shall be specified on a lamacoid plate, mounted adjacent to the receptacle, to help ensure that an adequate power generator is brought to the site in an emergency.

The 100 amp receptacle is suitable for the following approximate horsepower ratings.
 - c) 600 V, 3 phase, 75 HP
 - d) 240 V, 3 phase, 30 HP
 - e) 240 V, 1 phase, 15 HP
 - f) Underground wiring in conduit from hydro pole to kiosk and from kiosk to pumping station, so that conduits are clear of the lifting davit.

3.6.5 **Ventilation**

A wet well ventilation fan with capacity for five (5) minute air change (12 air changes/hour), activated by manual switch in the kiosk, shall be provided. This requirement can be halved when the supply air temperature is 10°C or less. Note that continuous operation can cause freezing problems.

3.6.6 **Lighting**

An explosion proof light in the wet well shall be provided. Note that the light switch must also activate the wet well fan. Alternatively, an explosion proof extension light shall be permanently installed in kiosk, wired to the light/fan switch mounted in the kiosk.

3.6.7 **Circuit Breakers**

- 1) Incoming power shall have circuit breaker protection rather than fuse protection.
- 2) Motor branch circuits shall have circuit breakers with magnetic only trip units.

3.6.8 **Nameplates**

- 1) All switches, panelboards, panels and equipment shall be identified with engraved "lamicoid" nameplates.
- 2) Motor nameplate information shall be permanently mounted in the kiosk in a convenient location on lamicoid labels so the electrician can set the overloads and check the current draw.

3.6.9 **Transformers**

- 1) A 120/240 single phase, or 120/208 three phase transformer for heating, lighting, fan, receptacles and alarm system shall be provided.
- 2) A separate 120 volt single phase control transformer with secondary circuit breaker for station control circuitry shall be provided to prevent loss of station operation due to malfunction of any of any system noted above.

3.6.10 **Level Regulators and Controls**

- 1) Level regulators shall be connected to direct current, intrinsically safe control relays approved for use with switches located in Class I, Zone 2, Group D hazardous locations.
- 2) Equipment to prevent the tangling and fouling of float switches shall be provided.
- 3) Automatic pump alternation shall be provided to give equal pump wear.

3.6.11 **Junction Boxes**

There shall not be any control or power wiring junction boxes at or in the wet well, and there shall not be any splices in the control or power cables. Control and power cables shall run through ventilation duct(s), then terminate at Class 1, Zone 2, Group D rated junction box(es) within the box(es) shall have seals installed in accordance with the Canadian Electrical Code.

3.6.12 **Power Quality Monitors**

Power quality monitors shall be provided as noted below to provide information about and protection from power supply problems so maintenance personnel can assess cause if problems develop:

- 1) single phase - Agastat Series VMA under voltage relay.
- 2) three phase - Agastat Series PMA power quality monitor.

3.7 **HEATING AND VENTILATING**

3.7.1 **Air Supply Fan**

All wastewater pumping stations shall have an air supply fan located in a separate compartment in the kiosk with a minimum 100 mm diameter stainless steel pipe supply duct to a level 1.0 metres above the high level alarm level. The fan shall force fresh air into the wet well rather than exhaust from the wet well. Ventilation intake shall be at least 300 mm above the highest anticipated snow level. Include a sign on the entrance hatch, "DANGER - TURN ON FAN AND VENT WET WELL FOR 10 MINUTES PRIOR TO ENTERING - NO SMOKING IN WET WELL".

3.7.2 **Exhaust Vent**

The pumping station shall have a minimum 100 mm diameter pipe exhaust vent with 180 degree elbow and shall have a galvanized mesh screen with 6 mm openings welded to the exhaust vent. Inlet and outlet ventilation pipes to be flange connected to the wet well.

3.7.3 **Heating**

The kiosk shall have a heater as detailed in Section 3.6.4(4).

3.7.4 **Insulation**

The kiosk shall be fully insulated with a minimum 25 mm of compressed fiberglass board insulation, having oil impervious membrane, and mechanically fastened to the interior walls with aluminum domed push-on caps.

3.7.5 **Kiosk**

- 1) In climatic areas where summer temperatures exceed 35 degrees C, mechanical ventilation of the kiosk shall be provided.
- 2) Small drainage/vent holes in the floor of the kiosk shall be provided. In view of the heating requirements, the ventilation shall be kept to a minimum.

3.8 INSTRUMENTATION AND CONTROLS

3.8.1 Level Controls

- 1) Wet well level regulators should provide the following controls:
 - a) Pump No. 2 - ON
 - b) High Level Alarm
 - c) Pump No. 1 - ON
 - d) Pumps No. 1 and No. 2 – OFF

These controls ensure that a high level alarm results if either pump alone is not keeping up with the inflow (note that each pump is sized to handle the peak design flow, and the second pump functions as a backup). A low level alarm can be considered for the eventuality that the stop float malfunctions and a pump attempts to operate.

- 2) Each level control shall be an independent float switch regulator. A spare level regulator for each type in the station (i.e. normally open or normally closed) shall be provided with each station. An ultrasonic sensor may also be used for level sensing and pump control, except for backup pump operation, as noted below.
- 3) A back-up relay timer pump operation control system shall be provided to start both pumps and run for a timed interval upon the high level float ball tripping. This back-up control system shall be independent of the normal ultrasonic or float ball system. The "independent" mode means that the backup pump start will occur even if the lead pump start level control is not operational.

3.8.2 Programmable Logic Controller (PLC)

PLC systems can be considered on a project specific basis and if proposed, must be substantiated on technical, operation, maintenance, and cost effectiveness bases by the Qualified Professional.

3.8.3 Hour Meters

Each pump shall have an hour meter.

3.8.4 Alarms

Each pumping station shall have an alarm system tied into a flashing red light and buzzer on top of the kiosk with a "silence" disconnect switch. A red light for each alarm and manual resets on the panel shall be provided for high level and pump failure (overload). If seal leak detection is installed, this shall be connected to an indication light; if a high temperature sensor is installed, the signal shall be connected to an alarm and should shutdown the motor. An uninterruptible power

supply (UPS) capable of powering the alarm for a minimum of 24 hours shall be provided. Pumps larger than 30 HP may warrant additional alarms. Consideration shall also be given to installing a telemetered alarm system.

3.8.5 **Surge Control**

Stations and associated forcemains that require surge control protection to limit water hammer events, shall utilize solid-state starters with ramp-up and down control of up to 30 seconds closing is envisioned. For longer ramp-up and ramp-down times, variable speed drives shall be used.

3.8.6 **Engine Driven Generators**

Where the electric power supply is generated through fuel combustion, staggered starting of the two pumps shall be ensured.

3.8.7 **Flow Measurement**

Where possible, suitable devices for measuring wastewater flow should be provided at all pumping stations. Indicating, totalizing and recording flow measurement devices/instruments should be provided. Flow recording activities shall be included in the Operation and Maintenance Plan.

3.8.8 **Power Surge Protection**

Design of instrumentation and control systems shall include power surge protection.

3.9 OPERATION INSTRUCTIONS, SPECIAL TOOLS AND SPARE PARTS

A complete set of operation instructions, including emergency procedures, maintenance schedules, special tools, and such spare parts as may be necessary shall be provided.

3.10 FORCEMAINS

3.10.1 **Velocity**

At design minimum flow (i.e. maximum static head, minimum C value), a velocity of at least 0.75 m/s shall be maintained for raw wastewater. For wastewater effluent, a minimum velocity of 0.61 m/s is acceptable at minimum design flows. A forcemain shall be a minimum 75 mm inside diameter for no-clog pumps and minimum 63 mm inside diameter for grinder pumps.

3.10.2 **Air Relief and Combination Air-Vacuum Relief Valves**

Automatic wastewater air relief valves shall be placed at high points in the forcemain to prevent air locking. Combination air and vacuum relief valves shall also be utilized as appropriate to protect the forcemain from air locking and vacuum condition which may collapse the pipe.

3.10.3 **Termination**

Forcemains shall enter the gravity sewer system at a manhole and at a point not more than 300 mm above the flow line of the receiving manhole.

3.10.4 **Design Pressure**

The forcemain and fittings, including reaction blocking, shall be designed to withstand normal pressure and pressure surges (water hammer).

3.10.5 **Swabbing**

Provision for swabbing shall be provided.

3.10.6 **Special Construction**

Forcemain construction near streams or used for aerial crossings shall meet applicable guidelines in Part 2.

3.10.7 **Design Friction Losses**

Friction losses through forcemains shall be based on the Hazen-Williams formula or other acceptable methods. When the Hazen-Williams formula is used, the values for "C" shall be used for design as noted below.

When initially installed, forcemains will have a significantly higher "C" factor. The higher "C" factor shall be considered only in calculating maximum power requirements.

The Hazen-Williams formula is as given below in equation 3-1:

$$h_f = 10,700 \left(\frac{Q}{C} \right)^{1.85} D^{-4.87} \quad (3-1)$$

Where

- h_f = headloss in metres per 1000 metres.
- Q = flow in cubic metres per second.
- C = Hazen-Williams factor
- D = pipe diameter in metres.

3.10.8 **System Curves**

Two systems curves shall be developed as follows.

- 1) Maximum static head, minimum C value:
110 for PVC and HDPE
100 for all others.
- 2) Minimum static head, maximum C value:
150 for PVC and HDPE
140 for all others.

These curves shall be shown on design drawings and up-dated on the as-built drawings along with the field tested pump rate. Refer to Section 3.4.2 and 3.4.2(2).

3.10.9 **Separation From Watermains**

There shall be at least a 3.3 m horizontal separation between watermains and sanitary sewer forcemains. Wastewater force mains shall cross under water mains and shall be laid to provide a minimum vertical distance of 450 mm between the outside of the forcemain and the outside of the watermain. At a crossing, one full length of water pipe shall be located so both joints will be as far from the forcemain as possible. Special structural support for the watermain and the forcemain may be required.

3.10.10 **Identification**

Where forcemains are constructed of material which might cause the forcemain to be confused with potable watermains, the forcemain shall be appropriately identified (e.g. with a red stripe).

PART 4 – WASTEWATER TREATMENT

4.1 GENERAL

The Qualified Professional shall refer to state-of-the-art science and engineering texts and standards for guidelines for the treatment processes listed in this section and others as appropriate. The investigation and design methodology shall be thoroughly and technically substantiated. A bibliography of technical references used shall be included in the design brief.

4.1.1 Effluent Quality Requirement

At a minimum, effluent quality for surface water discharges shall meet the requirements of Policy Statement #4; these minimum standards are based on the B.C. Municipal Sewage Regulation and on the Federal standards developed by the Canadian Council of Minister of the Environment. A copy of the Federal standards developed by the Canadian Council of Ministers of the Environment can be obtained from Environment Canada, and copies of the Municipal Sewage Regulation and its guidance documents can be obtained from the B.C. Ministry of Environment (Appendix VI). Notwithstanding the requirements that are set out in these documents, it is the responsibility of the Qualified Professional to ensure that all facilities conform to the most recent federal, provincial and local government standards.

4.1.2 Effluent Reclamation and Reuse

Reclamation and reuse of treated wastewater effluent is encouraged where this practice is shown to be appropriate and sustainable. Where reclamation and reuse of treated effluent is proposed, the standards for reclaimed water contained in the B.C. Municipal Sewage Regulation or any future updates shall be used. A copy of the Municipal Sewage Regulation and its guidance documents can be obtained from the B.C. Ministry of Environment (see Appendix VI).

4.1.3 Advanced Treatment

Where the need has been identified (e.g. in the Feasibility Report or the Pre-design Report), advanced treatment may be required. Depending on the site-specific requirements for protection of human health and the environment, advanced treatment may include removal of nutrients (nitrogen and/or phosphorus), oxidation of ammonia, effluent filtration to remove residual suspended solids, etc..

4.1.4 Disinfection

The need for disinfection to protect human health and the environment may be identified in the Feasibility Report or the Pre-design Report. Where the need for disinfection is identified, the use of technologies other than chlorination is preferred

(e.g. ultraviolet light). If chlorination is practiced, dechlorination to remove total residue chlorine in the effluent to below 0.02 mg/L is required (see Policy Statement #4).

4.1.5 Equipment and Process Reliability

Equipment and process reliability standards to ensure adequate standby treatment capacity in the event of equipment or process failure as set out in the Municipal Sewage Regulation or any future updates shall also apply.

4.2 *DESIGN FLOWS AND LOADS*

It is the responsibility of the Qualified Professional to determine a reasonable estimate of design wastewater flows and loading rates for collective residential and nonresidential systems. Where possible, design flow rates shall be developed from recorded flow data for the community under consideration or for similar communities. Where institutional, commercial and industrial contributions exist from a non-residential population, Table 2-1 can be used as a guide to estimate the contribution of non-residential population. The design loading for siting wastewater treatment facility should also take into consideration special events.

4.2.1 Hydraulic Design

The hydraulic components of the treatment system shall be designed to accommodate the peak wet weather flow (PWWF) if appropriate (i.e. with consideration for upstream pumping stations and diurnal flow patterns). In the absence of recorded flow data, the PWWF may be estimated by equation 2-1 in Section 2.1.

4.2.2 Treatment Process Design

Where local data are not available, the design mass load of five-day biochemical oxygen demand (CBOD₅) and total suspended solids (TSS) for residential discharges can be developed using as a minimum, an average of 75 grams/capita/day for both CBOD₅ and TSS. Allowances shall be included for peak mass loading conditions and peak flows as appropriate depending on the nature of the service area and the treatment process used and special events such as Potlatches and other community festivals.

For design of biological treatment processes, the design flow should be commensurate with the treatment process selected. For mechanical treatment plants with short retention times, the maximum week or maximum day flow and load may be appropriate, depending on the nature of the service area and the treatment process. For aerated lagoons, the maximum month flow and mass load are more appropriate for design, since the design hydraulic retention time for this type of process is 35 days (see Section 4.5).

Where estimation of the maximum day flow is required for design (e.g., for ground disposal fields), this should be undertaken in light of site specific data (where available) and conditions. In the absence of site-specific data, a value of 2 times the average dry weather flow can be used for estimating maximum day flow. Similarly, a value of 1.5 times the average dry weather flow can be used to estimate the maximum month flow in the absence of site specific data.

4.3 SEPTIC TANKS

4.3.1 Influent

All liquid waste and washwater shall discharge into the septic tank. Roof, footing, garage, and surface water drainage, and cooling water shall be excluded.

4.3.2 Location

The septic tank shall be located where it is readily accessible for emptying and inspection. The following are minimum horizontal separation distances that must be provided between the septic tank and the features indicated. The actual design horizontal separation distances will be dependent upon the site conditions and shall be specified through assessment by the specialist.

- g) Buildings and structures 1.0 m.
Water wells and suction lines 30 m.
Property lines 3.0 m.
Water supply lines under pressure 3.0 m.
Lakes and streams 30 m.

- h) Note: In determining the design horizontal separation to buildings and structures, the structural aspects of foundation stability and the protection of the septic tank from freezing and excessive heat loss during winter shall be considered. The maximum separation shall be no more than 1.5 m.

4.3.3 Typical configuration

Typical septic tank configurations are shown on Figure 4-1.

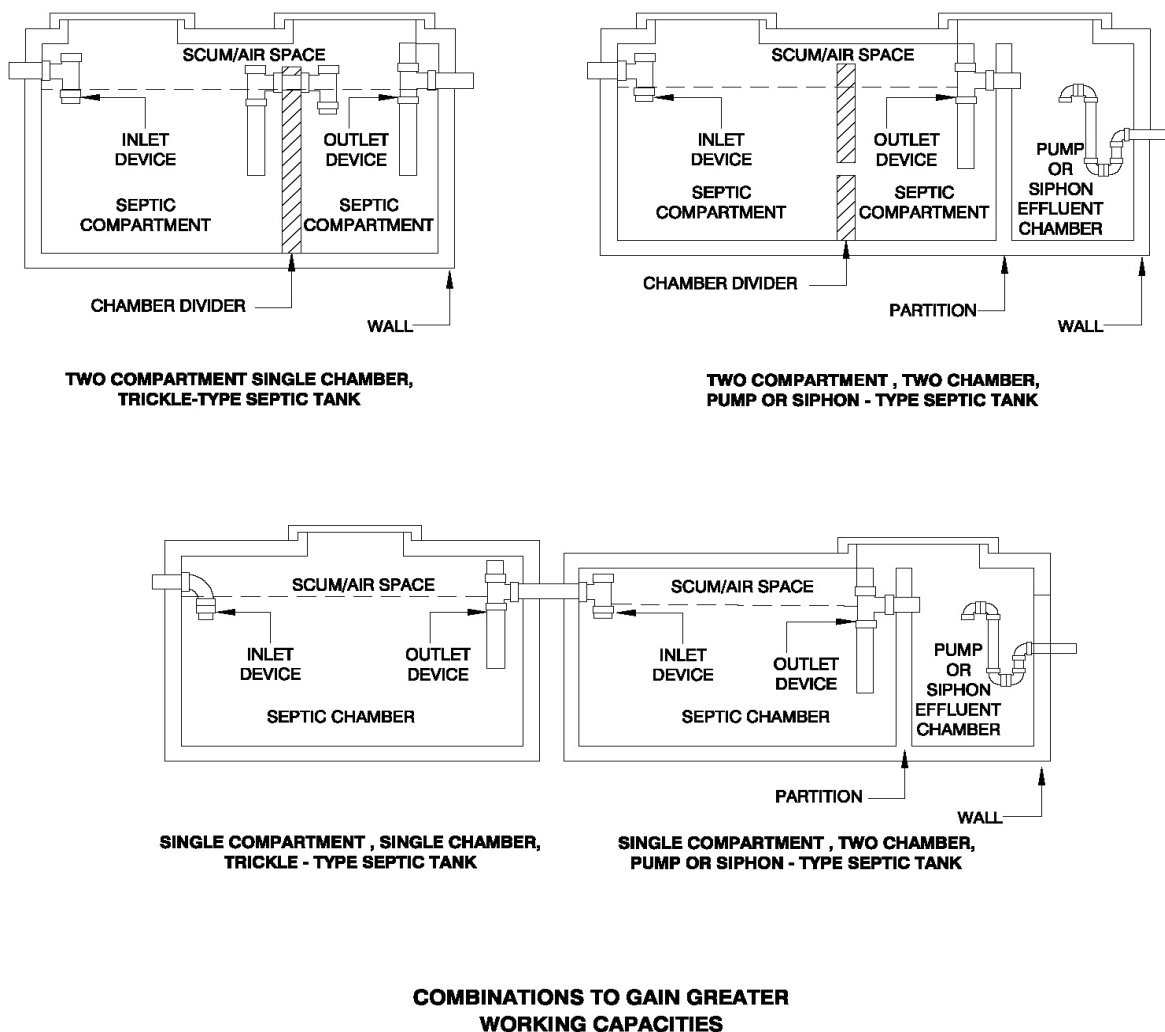

Figure 4-1: Typical Septic Tank Configurations (adapted from CSA B66-00)

4.3.4 Materials and Construction

The septic tank shall be constructed of sound and durable material not subject to excessive corrosion or decay and structurally capable of supporting the loads to which it will be subjected. The tank and connections shall be water-tight. The tanks shall be constructed and tested in strict accordance with the latest edition of Canadian Standard Association (CSA) standard, CSA B66, entitled "Design, Material, and Manufacturing Requirements for Prefabricated Septic Tanks and Sewage Holding Tanks". CSA Standard B66 shall be used to determine acceptability of tanks constructed on-site.

Prefabricated septic tanks shall conform to CAN/CSA-B66-M90. Note that in traveled areas tank may need to be designed for H-20 loading.

Steel tanks are not acceptable.

4.3.5 **Tank Capacity**

In calculating the tank capacity, the depth of the tank shall be the depth from the invert of the outlet to the floor of the tank.

The following schedule shall apply to septic tank capacity.

- 1) For individual systems the B.C. Ministry of Health Sewerage System Regulation and its associated guidance documents or any future updates shall apply (see Policy Statement #3 and Agency contact information in Appendix VI).
- 2) For collective systems the liquid capacity of a minimum of 48 hour retention time at the design flow shall be used for sizing the septic tank. The design flow for septic tanks shall be the estimated maximum day flow, based on the nature of the service area with consideration for special events such as Potlatches and other community festivals.

4.3.6 **Tank Dimensions and Liquid Depth**

The depth from the invert of the outlet to the floor of the tank (liquid depth) of any septic tank or compartment thereof shall not be less than 1.2 m. The length of a septic tank shall not be less than 1.5 m and shall be approximately two to three times the width and no tank or compartment thereof shall have an inside horizontal dimension less than 600 mm. The minimum inside diameter of a vertical cylindrical septic tank shall be 1.5 m. As a guideline, the tank surface area divided by tank depth should be greater than three for any compartment.

4.3.7 **Inlets**

The inlet connection to the septic tank shall not be less than 100 mm inside diameter and enter the tank at least 75 mm above the maximum liquid level. The inlet connection of the septic tank and each compartment thereof shall be submerged by means of a vented tee or baffled so as to obtain effective retention of scum and sludge. The inlet tee or baffle shall extend above the liquid level to a point not less than 25 mm from the underside of the top of the tank to assure system venting. The inlet baffle or tee shall extend below the liquid level at least 75 mm and not more than 20 percent of the total liquid depth. Baffles shall be located a minimum of 125 mm from the inlet pipe.

4.3.8 **Outlets**

The outlet connection to the septic tank shall not be less than 100 mm inside diameter. The outlet connection of the septic tank and each compartment thereof shall be submerged by means of a vented tee or baffled so as to obtain effective retention of scum and sludge. The outlet tee or baffle shall extend above the liquid level not less than 20 percent of the liquid depth in tanks with straight vertical sides and 15 percent of the liquid depth in horizontal cylindrical tanks. The outlet tee or baffle shall extend below the liquid level a distance not less than 25 percent of the

liquid depth, and not more than 40 percent of the liquid depth for tanks with straight vertical sides and not more than 35 percent of the liquid depth in horizontal cylindrical tanks. Baffles shall be located no more than 150 mm from the outlet pipe. There shall be at least a 25 mm vent space between the underside of the top of the tank and the top of the outlet baffle or tee.

4.3.9 **Effluent Filter**

Where septic tank effluent is discharge to a ground disposal field, septic tanks shall be fitted with a properly sized effluent filter that has an effective capacity to filter particles greater than or equal to 3 mm. The effluent filter shall be easily accessible for maintenance and inspection purposes. Effluent filters may also be installed in a separate chamber where installation in an existing septic tank is not practical. The effluent filter shall pass a minimum flow rate 50% greater than the peak daily flow, and when 85% clogged shall be able to pass a flow rate equivalent to the daily flow.

4.3.10 **Scum Storage and Venting**

A septic tank shall provide an air space having a volume not less than ten percent of the liquid capacity of the tank. Clearance of at least 230 mm shall be provided between the maximum liquid level at the outlet and the highest point on the ceiling of the tank body at each point along its length between the inlet and the outlet of the tank. Consideration shall be given to venting the septic tank and potential odour problems.

4.3.11 **Multiple Compartments**

- 1) Septic tanks shall be divided into at least two compartments. The liquid volume of the first compartment shall be equal to one-half to two-thirds ($1/2$ to $2/3$) of the total volume. The minimum size of the first compartment shall be 1820 L. A separate, third compartment may be required for pumping, dosing or distribution.
- 2) The minimum plan dimension of any compartment of the septic tank shall be 600 mm.
- 3) A vent space shall be provided between compartments of a septic tank. Inlets and outlets to a compartmented tank shall be proportioned and located as for a single tank. The liquid connection between compartments shall consist of two or more openings equally spaced across the width of the tank with an area equal to three times the inlet and located at a depth of 40 percent of the liquid depth as measured from the liquid level.

4.3.12 **Access and Inspection**

- 1) Adequate access to each compartment of the tank for inspection and sludge removal shall be provided by a standard manhole frame and cover of 610 mm minimum ID. When collective septic tanks have been installed with the top of

the tank more than 150 mm below grade, the manhole frame and cover shall be installed in standard 1050 mm ID precast manhole sections complete with precast concrete lid to H₂O loading, permitting manhole style access to the septic tank.

- 2) A minimum of two inspection holes shall be installed in each compartment to allow routine measurement of sludge accumulation. Inspection holes shall be evenly spaced.

4.3.13 **Collective Septic Tanks**

Collective septic tanks shall be custom designed to address adequate access for sludge measurement and desludging, and to enhance settleable and floatable solids removal through optimum inlet and outlet design (e.g. reduction of hydraulic short circuiting, use of gas/solids deflection baffles etc.)

For large collective septic tanks, sludge characteristics and quantities shall be considered when designing access for desludging. The scum may be very dense, with considerable grease content, and this requires access across a significant portion of the surface area in the first compartment to remove sludge efficiently.

A flow measurement system shall be included in systems that incorporate collective septic tanks. Acceptable methods of flow measurement include magnetic flowmeters, pump hour meters, and siphon counters.

4.3.14 **Twinning**

In addition to requirements for multiple compartments as described in Section 4.3.11(1), provision for twinned septic tank installation shall be made when the design flow exceeds 20 m³/d. For this condition a flow splitting manhole shall be provided immediately upstream of the twin septic tanks which will permit equal flow to each septic tank side during normal operation and temporary bypass of either septic tank side during pump out. The combined volume of the 2 septic tank sides shall equal that calculated in Section 4.3.5.

4.3.15 **Maintenance**

The depth of sludge and scum in collective septic tanks should be measured at least once every six months. A septic tank should be pumped out to remove accumulated solids before they escape to the second compartment. Typically this is when the thickness of the scum layer in the first compartment is about 15% of the liquid depth and the sludge reaches a depth of about 50% of the tank liquid depth. Under no circumstances, scum and sludge layers shall be allowed to accumulate to reach the bottom level of the outlet tee. The scum and sludge shall be pumped and disposed of in a sanitary and approved manner (see Section 4.3.16).

Operation and Maintenance Notes:

- 1) Records of pump-out activities must be kept by the operator and must be available for review by INAC.
- 2) Following septic tank cleaning, all interior surfaces of the tank shall be inspected using a strong light for leaks and cracks. Pumped-out septic tanks often contain toxic gases; therefore, only experienced persons using proper safety equipment shall attempt to enter or repair a septic tank if this shall become necessary.
- 3) At least once a year, dosing tanks and distribution boxes shall be opened, settled solids removed, and v-notch weirs adjusted as necessary.
- 4) The use of biological or chemical additives in the septic tank is not recommended.
- 5) System users should be discouraged from the use of garburators and discharge of toxic and hazardous wastes to sewer.

4.3.16 **Septage Treatment**

Septage is the accumulated sludge that must be periodically removed from septic tanks. In general, the standards for treatment of wastewater sludge that are set out in the B.C. Organic Matter Recycling Regulation or any future updates shall apply (see Policy Statement #8 and Agency contact information in Appendix VI). Septage is generally treated in one of the following ways.

1) Dedicated Septage Treatment Facilities

Septage can be discharged to dedicated treatment facilities, which may include stabilization lagoons or large municipal mechanical wastewater treatment plants.

2) Treatment at a municipal wastewater treatment plant

Disposal at a municipal wastewater treatment plant is often a cost effective solution. However, care must be taken not to overload the facility, as septage is more concentrated than typical wastewater. Septage is typically added to the treatment plant at an upstream sewer manhole, the treatment plant headworks or directly to the sludge handling process.

3) Composting

Septage can potentially be used along with other materials to produce compost. The B.C. Organic Matter Recycling Regulation or any updates shall be followed for septage composting and beneficial reuse of the biosolids.

4.4 FACULTATIVE STABILIZATION LAGOONS

A facultative lagoon system may be comprised of anaerobic fermentation cells, facultative treatment cells and/or a facultative/storage cell. Anaerobic fermentation cells provide pre-treatment by sedimentation and fermentation while facultative treatment cells provide the main secondary treatment.

A facultative/storage cell provision is generally required where discharge is to surface waters and depends on winter climatic conditions. During severe winter climatic conditions, ice cover eliminates surface aeration and subsequent snow cover reduces the production of photosynthetic oxygen to zero, thereby creating anaerobic conditions throughout the water column. The facultative/ storage cell thus provides storage and sedimentation in the winter and allows for effective treatment once the ice cover melts and the liquid temperature increases (these systems discharge on a seasonal basis only).

For multi-cell systems, whether facultative or aerated, permanent inground piping and control devices shall be incorporated to permit temporary bypass of individual treatment cells. Where possible, piping shall also permit multi-cell systems to operate either in series or parallel.



Facultative Lagoon

4.4.1 **General Requirements**

- 1) Before designing a facultative lagoon system, the Qualified Professional shall determine the following:
 - i) whether the lagoon can be continuously discharged or will operate on a seasonal discharge basis;
 - j) the period(s) of the year when a discharge will not be permitted;
 - k) what discharge rates will be permitted for storage lagoons during the seasonal discharge period and what, if any, provision should be made for controlling effluent discharge rates in proportion to receiving stream flow rates;
 - l) the minimum duration of discharge for storage lagoon cell contents.

- 2) For wastewater flows less than 20 m³/day, a single cell facultative lagoon system is acceptable, provided that the required effluent standard can be met. For flows in excess of 20 m³/day, a minimum two cell treatment system shall be used.

- 3) Treatment cell sizing should be based on the plug flow lagoon model as shown in equation 4-1*:

$$\frac{C_e}{C_o} = e^{-k_p t} \quad (4-1)$$

Where: t = detention time, days
 C_o = influent CBOD₅, mg/L
 C_e = effluent CBOD₅, mg/L
 k_p = plug flow first order reaction rate, day⁻¹

* other equivalent methods may be used – e.g., see “Design Manual Municipal Wastewater Stabilization Ponds” by the U.S. Environmental Protection Agency, EPA-625/1-83-015, or other relevant references.

For climatic areas without ice cover, an areal loading of 45 kg CBOD₅/ha/day shall not be exceeded for the treatment cell(s). The k_p value for a loading of 45 Kg CBOD₅/ha/day can be calculated according to equation 4-2:

$$k_p \text{ (at 45 kg CBOD}_5\text{/ha)} = 0.071 (1.09)^{T-20}. \quad (4-2)$$

Where: T = minimum operating lagoon water temperature, °C
 K_p = as defined for equation 4-2 above

For areas with seasonal ice coverage, an aerial loading of 22 kg CBOD₅/ha/day shall not be exceeded for the treatment cell(s). The k_p value for a loading of 22 kg CBOD₅/ha/day can be calculated according to equation 4-3:

$$k_p \text{ (at 22 kg CBOD}_5\text{/ha)} = 0.045 (1.09)^{T-20} \quad (4-3)$$

where T and K_p are as defined for equation 4-2 above.

4.4.2 **Anaerobic Cells**

Anaerobic cells shall operate at a depth of 3.0 to 5.0 m and retain influent flow for a 2 to 5 day period based on design flow rates.

To provide a cell bottom of at least 3.0 metres square for adequate mobility of construction equipment and sufficient bottom area for sludge accumulation, the minimum practical design volume of an anaerobic cell with 3:1 inside slopes and 3.0 m of operating depth is approximately 440 m³. Therefore, the minimum average design daily flow at which an anaerobic cell is practical is approximately 88 m³.

When design flows or loads warrant the inclusion of anaerobic cells, there should be a minimum of 2 cells operated in series.

4.4.3 **Facultative Cells**

The design normal operating liquid depth of facultative lagoons shall be 1.5 m, and under ice cover 1.2 m, exclusive of sludge storage. Under temporary operating conditions, the maximum and minimum operating depths that shall be allowed are 2.0 m and 0.6 m respectively.

Based on design flows, the cells shall have a minimum retention time of 30 days in climatic areas with average winter air temperatures above 0°C, and 60 days with average winter air temperatures below 0°C.

Extra depth shall be allowed for sludge storage and, in cold climates, for ice cover as described below.

1) **Solids Storage Volume**

The solids storage volume shall be based on equation 4-4.

$$\text{Solids Storage Volume} = \frac{1.5 \text{ m}^3 \text{ sludge}}{1000 \text{ m}^3 \text{ of sewage}} \times Q \times t \quad (4-4)$$

Where: Q = design flow, m³/d
t = number of days between desludging events

2) Ice Cover

Ice cover shall be assessed on a site-specific basis and can be calculated by the Stefan Equation (equation 4-5):

$$h = \epsilon (SFI)^{0.5} \quad (4-5)$$

Where:

- h = ice thickness, m
- SFI = freezing index at ground surface, °C-sec
 = summation of the degree-days below 0°C based on the mean daily temperature for the year (converted to °C - seconds). (Refer to the Canadian Climate Normals, published by Environment Canada, http://www.climate.weatheroffice.ec.gc.ca/climate_normals/index_e.html).
- ε = coefficient of proportionality, m/(°C^{0.5}sec^{0.5})

<u>"ε" Factor x 10⁻⁵</u>	<u>Conditions</u>
10.4 to 11.0	Practical maximum for ice not covered with snow
9.3	Windy lakes with no snow
8.1 to 9.3	Medium-sized lake with moderate snow cover
6.7 to 7.5	Rivers with moderate flow
4.6 to 5.8	River with snow
2.3 to 4.6	Small river with rapid flow

If no information is available, 1.0 m thick ice cover shall be assumed.

4.4.4 Facultative Storage Cell(s)

In cold climates where there is ice and snow cover, treatment efficiency drops significantly; long term storage with seasonal discharge during appropriate receiving water and effluent quality conditions may be required. Long-term storage with seasonal discharge provides additional wastewater treatment during warmer months (spring, summer and fall) under facultative conditions after the ice melts, and reduces the environmental impact on the receiving waters.

The facultative storage cell shall operate at a maximum depth of 2.5 m. The storage cell shall have a capacity at least equal to all wastewater flows during the ice cover period plus 2 months.

4.4.5 Controlled Seasonal Discharge

- 1) A drainage course receiving a seasonal discharge from a wastewater stabilization lagoon shall be capable of transporting the effluent to the ultimate receiving waters (streams, rivers, lakes, wetlands, estuaries, and ocean) without

the occurrence of either flooding of adjacent lands or erosion of the drainage course itself.

- 2) For seasonal discharges to receiving waters such as streams, rivers and lakes, the time of year and duration depends on regulations and receiving water protection requirements. Factors such as dilution ratios (i.e. rate of discharge and stream/river flow conditions) and effluent quality shall be considered. Selection of the season(s) of discharge shall be included in the Environmental Assessment Report. Refer to Section 4.4.4 – Facultative Storage Cell(s).

4.5 PARTIAL MIX AERATED LAGOON SYSTEMS

Aerated lagoons are composed of a series of aerated cells with tapered aeration followed by a polishing cell or quiescent zone for settling out of suspended solids. Partial-mix aerated lagoons are normally designed so that the aeration system provides adequate oxygen transfer and mixing to satisfy the biochemical oxygen demand, but does not provide sufficient energy to maintain all of the solids in suspension.



Lagoon Surface Aerators

4.5.1 **General Requirements**

In designing partial mix aerated lagoons, consideration shall be given to the following:

- m) CBOD₅ removal
- n) Effluent characteristics
- o) Oxygen requirements
- p) Mixing requirements
- q) Wastewater and air temperature
- r) Oxygen transfer and mixing equipment
- s) Solids separation

4.5.2 **Number of Cells**

A minimum of two cells shall be required, and three or four cells are preferred. A polishing zone or cell shall be provided.

4.5.3 **Sizing of Treatment Cells**

The aeration cells should be of equal volume. Minimum detention shall be 30 days in the aerated cells and 5 days in polishing cells. Under extenuating circumstances (e.g., insufficient space available), a shorter detention time may be considered on a case-by-case basis; written justification is required for shorter detention times.

Additional volume for solids storage and ice cover shall be provided. For details refer to Section 4.4.3(1) – Solids Storage Volume and Section 4.4.3(2) - Ice Cover.

The partial mix lagoon model or equivalent method shall be used for sizing partial-mix aerated lagoons as shown in equation 4-6.

$$t = \frac{n}{k_{pm}} \left[\left[\frac{C_o}{C_n} \right]^{1/n} - 1 \right] \quad (4-6)$$

Where:

- t = minimum total detention time, days (excluding polishing cells)
- n = number of cells in series
- C_o = influent CBOD₅, mg/L
- C_n = effluent CBOD₅ from the nth cell in a n cell series, mg/L
- k_{pm} = reaction rate for an aerated lagoon, at design temperature

The reaction rate, k_{pm} , can be adjusted for temperature by equation 4-7:

$$\frac{k_{pm}}{k_{pm20}} = \Theta_w^{(T_w - 20)} \quad (4-7)$$

Where: k_{pm} = reaction rate at design temperature, days⁻¹
 k_{pm20} = reaction rate at 20°C, days⁻¹ = 0.276 day⁻¹
 Θ_w = temperature factor, dimensionless = 1.036
 T_w = temperature of lagoon water, °C

The reaction rate noted above is for domestic wastewater; if the wastewater includes industrial wastes, other wastes and partially treated wastewater, the reaction rate should be determined experimentally for various conditions which might be encountered in the aerated lagoons. Conversion of the reaction rate coefficient at other temperatures should be made based on experimental data.

The impact of mixing and the ambient air temperature on the lagoon water temperature can be calculated from equation 4-8:

$$T_w = \frac{A f T_a + Q T_i}{A f + Q} \quad (4-8)$$

Where: T_w = lagoon water temperature, °C
 T_a = ambient air temperature, °C
 T_i = influent wastewater temperature, °C
 A = surface area of lagoon, m²
 f = proportionality factor = 0.5
 Q = wastewater flow rate, m³/day

Equations 4-6, 4-7 and 4-8 can be combined and solved on a trial and error basis. That is, a lagoon temperature is assumed and k_{pm} is adjusted accordingly using Equation (4-8). The system detention time t is then calculated using Equation (4-6). The required volume and surface area is then calculated, and the lagoon temperature is estimated using Equation (4-8). The lagoon temperature is then adjusted if necessary and additional iterations are performed as needed. Notwithstanding the above, the minimum lagoon water temperature used for design purposes should not be less than 2°C.

4.54 **Design Depth**

The design water depth of the aerated cell(s) shall be 3.0 to 4.5 m; this depth limitation may be altered depending on the optimum aeration equipment efficiency, waste strength, and climatic conditions.

4.5.5 Polishing Cell

A quiescent settling zone for suspended solids shall be provided as the last cell or as part of the last cell. The choice of whether to create a separate polishing cell from the aeration cell(s) will depend on the size of the system and the type of aeration equipment. The settling zone shall have a retention time of at least five days at the design flow rate.

4.5.6 Aeration Requirement

Aeration is used to partially mix the cell contents and to transfer oxygen to the liquid. Oxygen requirements generally depend on the maximum diurnal CBOD₅ loading, the degree of treatment, the concentration of suspended solids to be maintained in the lagoons, and other factors such as benthic oxygen demand and oxidation of ammonia.

- 1) Aeration equipment shall be capable of maintaining a minimum of 2.0 mg/L of dissolved oxygen in the mixed liquor at all times. Dissolved oxygen meters are recommended for checking and possibly controlling this aspect. In the absence of experimentally determined values, the design oxygen requirements for aerated lagoons shall be 1.5 kg O₂/kg peak CBOD₅ applied. In cold climates, however, the ratio of 2 kg/kg CBOD₅ removed shall be used for sizing the aeration equipment.
- 2) The design oxygen requirement calculated must be adjusted for field conditions (i.e. altitude, dissolved oxygen level expected to be maintained and the lagoon liquid and temperature) in accordance with equation 4-9:

$$\frac{AOR}{SOR} = \frac{E}{E_o} = \frac{(\beta)(C_s) - C_L}{C_{20}} (\alpha)^{\Theta^{T-20}} \quad (4-9)$$

Where:

- AOR = rate of oxygen input into wastewater under actual conditions, kg/hr/kW
- SOR = rate of oxygen input under standard conditions, kg/hr/kW
- E = actual oxygen absorption efficiency
- E_o = oxygen absorption efficiency under standard conditions, varies from 4 to 12 percent for diffusers and spargers in domestic wastewater. The variation depends on bubble size and the general design and arrangement in the lagoon.
- α = oxygen transfer correction factor for waste. In the absence of an experimentally determined alpha value, a factor of 0.85 can be assumed for the systems treating primarily (90% or greater) domestic wastewater. Where the wastewater contains a higher percentage of industrial wastes, a correspondingly lower value shall be used and calculations shall be included in the design brief to justify such a value.

- β = the ratio of saturation values of wastewater to clean water at actual wastewater temperature and actual atmosphere pressure (approximately 0.9 for domestic wastewater)
- C_L = desired dissolved oxygen concentration in the lagoon, mg/L, assume 2.0 mg/L minimum
- C_{20} = saturation value of oxygen in clean water at standard conditions, equal to 9.17 mg/L
- C_s = saturation value of dissolved oxygen in clean water at actual water temperature and altitude above sea level
- T = liquid temperature in lagoon, °C
- Θ = empirical correction factor assumed to equal 1.024, unless aeration system tests show a different factor

- 3) Having determined the oxygen absorption efficiency, air requirements for a diffused air system can be calculated from equation 4-10:

$$Q_a = \frac{O_r}{(1.2)(E)} \quad (4-10)$$

Where: Q_a = air required, Std m³/hr

O_r = oxygen required, kg/hr (i.e. 1.5 kg O₂/kg CBOD₅ or 2.0 kg O₂/kg CBOD₅ as noted previously)
Density of air = 1.2 kg/m³ at standard conditions (20°C, 1 atm)

- 4) Heavier aeration shall be provided at the lagoon influent to maintain influent solids in suspension and to meet the high influent CBOD₅ demand. In partial mix aerated cells, power input can be reduced in each succeeding cell because of the reduction in organic matter to be oxidized as the wastewater flows through the system.
- 5) Careful consideration shall be given to maximizing oxygen utilization per unit power input. Final sizing of aeration equipment shall be based on guaranteed performance by an equipment manufacturer. Certified testing, in accordance with the latest ASCE testing procedures, shall be provided to verify the mechanical aerator's performance.



Lagoon Aeration Blowers

4.5.7 **Diffused Air System**

Non-clog type diffusers are recommended. The air diffusion piping and diffuser system shall be capable of delivering normal air requirements with minimal friction losses.

Air piping systems shall be designed such that the total head loss from blower outlet (or silencer outlet where used) to the diffuser inlet does not exceed 0.035 kg/cm^2 (0.5 psi) at average operating conditions.

Air piping shall be sloped from the blowers to the lagoons for draining condensate to the lagoon(s), or a condensate trap with valve cock and drain shall be employed.

Diffuser systems shall be selected to minimize maintenance requirements. If fine bubble diffusers are used, systems that allow servicing of the diffusers without draining the lagoon are preferred.

The spacing of diffusers shall be in accordance with the oxygen requirements through the length of the cell and the cell mixing requirements, and shall be designed to facilitate adjustment of their spacing without major revision to air header piping.

Individual assembly units of diffusers shall be equipped with control valves and preferably with air flow indicators for throttling or for complete shutoff. Diffusers in any single assembly shall have uniform pressure loss.

The specified capacity of blowers or air compressors, particularly centrifugal blowers, shall take into account that the air intake temperature may reach 40 °C or higher and that the pressure may be less than normal. The specified capacity of the motor drive shall also take into account that the intake air may be -30 °C or less and may require oversizing of the motor or a means of reducing the rate of air delivery to prevent overheating or damage to the motor.

The blowers shall be provided in multiple units, so arranged and in such capacities as to meet the maximum air demand with the single largest unit out of service. The design shall also provide for varying the volume of air delivered in proportion to the load demand of the treatment system.

To prevent damage to blowers and clogging of the diffusers, air filters shall be provided in numbers, arrangements, and capacities to furnish at all times an air supply sufficiently free from dust.

4.5.8 **Mechanical Aeration**

The mechanism and drive unit shall be designed for the expected conditions in the aerated lagoon in terms of the power performance. The design requirements of a mechanical aeration system shall accomplish the following:

- 1) meet maximum oxygen demand and maintain process performance with the largest unit out of service;
- 2) provide for varying the amount of oxygen transferred in proportion to the load demand on the lagoon(s) (e.g., be removing selected aerators from service);
- 3) ensure that adequate pumping or mixing is provided to maintain a uniform dissolved oxygen level in the cell;
- 4) provide overlapping zones of mixing with aerators spaced in proportion to the expected oxygen demand, accounting for a decrease in the oxygen demand in each succeeding cell;
- 5) where extended cold weather conditions are expected and mechanical aeration is selected, submerged impeller type surface aerators shall be used, since partially submerged impeller types are subject to ice accumulation;
- 6) ensure that where extended cold weather conditions occur, shaft heaters or other methods of protection from freezing are provided, so that the aerator mechanism can be freed of ice following a power outage; and
- 7) ensure that the impeller is positioned below the potential ice depth.

4.6 DESIGN CONSIDERATION FOR LAGOON SYSTEMS

4.6.1 Seepage

Seepage from wastewater lagoons is one of the most important aspects of lagoon design, construction, operation and maintenance.

The maximum allowable seepage shall be 5.2×10^{-9} m/s where seepage is prohibited or undesirable.

The maximum allowable hydraulic conductivity for lagoon liners consisting of in-situ soil materials, compacted clay, bentonite and sand, asphaltic concrete or other porous materials in which seepage is governed by Darcy's Law, shall be calculated using equation 4-11:

$$K_t = \frac{5.2 \times 10^{-9} \times d}{2 + d} \quad (4-11)$$

Where: K_t = maximum allowable hydraulic conductivity of liner in the field, being at least one order of magnitude greater than the laboratory value, m/s

d = required or proposed thickness of liner, metres

When some discharge occurs by means of infiltration into the surrounding ground, ground water movement and its potential contamination shall be considered.

4.6.2 Water Mass Balance

To maintain a satisfactory water level in the lagoon system, the design shall include an assessment of the water balance. The water balance in a lagoon is dependent upon inflow, outflow, precipitation, evaporation, infiltration and seepage. Special attention shall be taken during the initial period, when the wastewater flow is much lower than the design flow, to prevent desiccation of the soil liner materials and berm erosion.

When designing for storage losses, the Qualified Professional shall ensure that a minimum operating depth of 0.6 m is maintained in facultative lagoons. Minimum depths for partial mix aerated lagoons shall be selected in accordance with aerator manufacturer's recommendations. The use of impermeable membranes as liners to minimize the exfiltration of lagoon liquid may be a necessary requirement as dictated by the soil conditions and potential environmental impact.

4.6.3 **Setback Distances**

Setback distances from wastewater stabilization lagoons are required to buffer the effect of potential odours and to provide a margin of public safety. Buffer zones also serve to protect the physical integrity of nearby buildings and roads.

The minimum horizontal setback distances for wastewater stabilization lagoons are shown in Table 4-2.

TABLE 4-2
SETBACK DISTANCES FROM COLLECTIVE WASTEWATER
STABILIZATION LAGOONS (OUTSIDE BERM TOE)

To	Minimum Setback (m)	
	For Anaerobic and Facultative Lagoons	For Aerobic Lagoons
The property line of any residential, commercial or industrial property, or the designated right-of-way of a rural road or railway	30	30
The designated right-of-way of any primary or secondary highway	100	30
Any existing or potential residential or institutional buildings (e.g. house, school, church, hospital, community centre)	300	100

4.6.4 **Physical Site Constraints**

The wastewater stabilization lagoons shall not be located in any area which is prone to flooding during large storm events. The top of the berms shall be at or above the one in 200-year flood return elevation. On a site-specific basis, it may also be necessary to provide an adequate setback distance to adjacent drainage course.

The lagoons shall not intercept surface run-off, groundwater or snow melt.

For facultative lagoons, the site selected shall have maximum sunlight reaching the surface. In a hilly area, the south side of hills is preferred.

4.6.5 **Prevailing Winds**

In relation to inhabited areas, lagoons shall not be located upwind in the direction of the local prevailing winds.

To reduce short circuiting due to induced current generated by winds, facultative and storage lagoons shall be oriented with their lengths perpendicular to the direction of the local prevailing winds.

4.6.6 **Geotechnical Information**

A geotechnical investigation and report is recommended for all earthen berm construction to determine the suitability of the soils, the limiting site conditions, and the construction procedures. Soil borings, laboratory analyses data, and groundwater conditions shall be used to determine the design and construction criteria and the operation requirements for the proposed lagoons.

The geotechnical investigation shall include a minimum of 5 boreholes, or one borehole per 2 ha of cell area. At least one borehole should be a minimum of 20 m in depth or into bedrock, whichever is shallower. At least 3 boreholes shall penetrate the groundwater table. If bedrock is encountered, rock type, structure and corresponding geological formation data shall be provided. The boring shall be filled and sealed. The permeability characteristics of the lagoon bottom and lagoon seal materials shall also be addressed.

A minimum separation of 3.0 m between the lagoon bottom and any bedrock formation is recommended.

Lagoons shall not be located in areas that may be subject to karst topography.

4.6.7 **Hydrogeology**

Construction of lagoons in close proximity to water supplies and other water bodies sensitive to contamination shall be avoided. In these areas, a minimum separation of 1.2 m between the bottom of the lagoon and the groundwater elevation shall be maintained.

4.6.8 **Groundwater Monitoring**

Groundwater monitoring standpipes (wells) shall be installed to determine the effectiveness of installed seepage control measures and to identify any existing or potential seepage related problems. Groundwater observation standpipes may be required during the site investigation program, installed in exploration boreholes outside the lagoons.

Monitoring wells should be constructed of PVC schedule 40 pipe, nominal 75 mm diameter, with the above ground portion of the pipe having a metal protector or other barrier system. Wells should be lockable to prevent tampering. The screen shall be PVC and shall be surrounded by gravel or sand. The remaining annulus shall be sealed with bentonite or cement slurry.

There shall be a minimum of 4 monitor well installations per site. Wells shall be located close to the perimeter of lagoon berms. At least one standpipe shall be upgradient from the lagoon to provide background water quality data. The number and location of monitoring wells, the frequency of groundwater monitoring, and the water quality analyses will vary based on local factors and shall be established during the engineering design and reflected in the Operation and Maintenance Plan.

The following monitoring program or a monitoring program as otherwise recommended by the Qualified Professional shall be followed for all new wastewater lagoons and shall be reflected in the Operation and Maintenance Plan.

- 1) Each monitoring well shall be analyzed for physical, chemical and biological parameters quarterly during the first year of operation. This will provide the baseline data to be compared with future analysis.
- 2) The first analysis from each monitoring well shall be undertaken prior to putting a new lagoon into operation. The following three analyses shall be carried out approximately three months apart to cover all seasons in the year.
- 3) Water samples shall be analyzed for parameters as appropriate in light of site-specific environmental studies (see Sections 1.2.11 and 1.3.9.7)).
- 4) Wells shall be monitored for water levels whenever a sample is collected for chemical analysis, and also during the lagoon discharge period. During the lagoon drainage period, one set of readings shall be taken:
 - a) Immediately before discharge
 - b) Immediately after discharge, and
 - c) approximately one month after the end of the discharge period

4.6.9 **Surface Run-off Diversion**

Adequate site drainage shall be provided to divert surface run-off that would otherwise cause damage to the system.

4.6.10 **Natural In Situ Liners**

In situ liners shall have a minimum thickness of at least 0.9 m below the entire bottom, shall be relatively uniform and homogeneous, and shall be completely free of hydrogeologic windows such as sand and silt. Engineered sideslope liners shall be provided if the horizontal hydraulic conductivity of the in situ liner does not meet the seepage control criterion (see Section 4.5.9 Seepage);

4.6.11 **Compacted Clay Liners**

Compacted clay liners shall have a minimum thickness of 0.6 m on the bottom and 1.2 m on the sideslope (measured perpendicular to the slope). The liner shall be

constructed in 150 mm to 200 mm lifts and compacted to the required density, within the required moisture content range, to achieve the required seepage control criterion. When determining whether the seepage control criterion is met, the actual hydraulic conductivity of the liner in the field shall be assumed to be at least one order of magnitude greater than laboratory values;

4.6.12 **Bentonite and Sand Admix Liners**

Bentonite shall only be considered for lagoon liners where mixing with native sands or silts allows a uniform bentonite and sand/silt admix. Only moderate to high swelling sodium bentonite shall be used. The bentonite application rate required to meet the seepage control criterion shall be determined by laboratory permeability tests and then increased by 25% to allow for field conditions. The admix liner shall be at least 100 mm thick after compaction, and any portion of the liner that is susceptible to weathering when exposed shall be covered with suitable soil material;

4.6.13 **Asphalt Liners**

The only asphalt liner shall be spray-on bitumen over asphaltic concrete or soil asphalt. Hydraulic asphaltic concrete liners shall be a minimum of 100 mm thick comprising two 50 mm lifts with staggered joints. Soil asphalt liners shall be mixed with 150 mm of native sandy soil. In all cases, asphalt shall be placed over non-frost susceptible base courses or subgrades. The spray-on bitumen covering the hydraulic asphaltic concrete or soil asphalt surface shall provide a uniform 2 mm thick membrane;

4.6.14 **Flexible Polymeric Membrane Liners**

The minimum thickness of membranes shall be 20 mils. Membranes less than 60 mils thick shall be covered with a 300 mm layer of fine-grained soil on the berm sideslopes to prevent liner damage. PVC and other membrane liner materials that are susceptible to weathering (e.g. UV degradation) shall be covered with soil on both the sideslopes and bottom. A stable and well prepared subgrade and proper membrane installation, with particular emphasis on seaming, shall be provided. A system for venting gas generation beneath the liner shall be considered if the need is identified.

4.6.15 **Access**

An all weather access road shall be provided to the lagoon site to allow year-round maintenance of the facility.

4.6.16 **Fencing**

The lagoons shall be enclosed with a fence unless other means of controlling access are provided. Partial fencing may be considered. The fence shall be designed and

constructed to preclude the entrance of children and to discourage trespassing. The fence shall also serve to preclude the entrance of livestock.

Fences shall be located away from the outside toe of the berms by at least 1.0 m to facilitate mowing and maintenance operations. An access gate shall be provided to allow entry of maintenance equipment and vehicles. The gate shall be provided with a lock to preclude entrance of unauthorized persons.

4.6.17 **Warning Signs**

Warning signs shall be provided at appropriate locations along the fenced perimeter of the wastewater stabilization lagoons. Each sign shall identify the nature of the facility and owner, advise against trespassing, and provide emergency contact names, phone numbers and/or addresses.

4.6.18 **Winter Protection**

Special care shall be taken to avoid freezing problems for the transfer piping between lagoon cells when transferring from one cell to another. The application of adequate insulation and/or addition of heat tracing at the transfer points may be required.

If baffle curtains are designed to extend into the freezing zone, the baffles shall be designed against ice damage.

Mechanical equipment and aerators exposed to the winter elements should be equipped with winter heat tracing or otherwise “winterized”.

Suitable protection of electrical controls from weather shall be provided.

4.6.19 **Piping and Channels**

All interconnecting and lagoon bypass piping shall be PVC or ductile iron and shall meet the requirements set out in Section 2.3. Where settlement is a concern (due to freeze/thaw conditions or otherwise), the piping shall be installed so as not to jeopardize the integrity of the lagoon liner or seal. Pipe shall be anchored with adequate erosion control.

Where cells are at or near the same elevation, the interconnecting pipes shall include isolation valves. Where cell elevations differ significantly, the cross connection pipe shall have a chamber with a weir to control flow from the higher cell. The valve or chamber shall be provided with suitable locking devices, and be located off the travelled portion of the top of the berm.

For continuous discharge, the hydraulic capacity of pipes and channels within the lagoon system and for discharge structures shall be designed for at least 2.5 times the average annual flow.

Channels and pipes carrying liquids with solids in suspension shall be designed to maintain self-cleansing velocity of 0.6 m/s within the design limits. Adequate provisions shall be made to drain segments of channels which are not being used due to alternate flow patterns.

The hydraulic capacity for seasonal discharge systems shall permit transfer of water at a minimum rate of 150 mm of lagoon water depth per day at the available head, and shall have adequate capacity for the maximum design discharge rate.

4.6.20 **Flow Distribution Structures**

Manholes shall meet the requirements of Section 2.4. Control manholes are commonly used for access to inlet piping and to regulate the flow from the influent pipeline to the cells. The invert(s) shall be at least 150 mm above the maximum operating level and provide sufficient hydraulic head without surcharging the upstream manhole.

Flow distribution structures and piping shall be designed to allow the following modes of operation:

- a) effectively splitting of hydraulic and organic loads equally to the cells;
- b) isolation of the cells;
- c) temporary bypassing of individual cells; and
- t) where possible, operation in either series or parallel.

4.6.21 **Inlet/Outlet Structures**

To help reducing short-circuiting, inlets and outlets shall be located at the mid point of each end of small lagoons.

Inlets and outlets for each cell shall be suitably equipped with valves, gates, stop plates, weirs, or other devices to permit controlling the flow to any cell and to maintain a reasonably constant liquid level. The hydraulic properties of the system shall permit the maximum instantaneous hydraulic load to be carried with any single cell out of service.

Inlet pipes to the lagoon shall have a positive slope into the cell(s) and should terminate with a concrete pad at the one-third cell depth.

An inlet chamber should be provided with a lockable aluminum cover plate or grating, divided into small enough sections to permit easy handling.

All aerated cells shall have influent lines that distribute the load within the mixing zone of the aeration equipment. Consideration of multiple inlets should be closely evaluated for any diffused aeration system.



UV Disinfection at Lagoon Outlet

4.6.22 **Drain Structures**

Where practical, lagoon drains should be provided to ensure that all cells are capable of being drained by gravity to within 300 mm of the cell bottom. A manhole shall be provided to house the final drain and outlet pipes. The drainage pipe shall be equipped with a long stem valve so that it can be operated without entering the manhole. Erosion protection may be required at the location of effluent discharge.

4.6.23 **Overflows**

Refer to Policy Statement #7.

4.6.24 **Flow Measurement**

Provision for flow measurement at the outlet of the lagoon system shall be made. Effluent weirs, flumes or other devices combined with their associated depth measurement method shall be capable of monitoring flow under all outlet conditions to within 5% accuracy based on manufacturer's specifications. If a V-notch weir is used, the system shall be designed to allow expedient visual readings of instantaneous flows without the need to enter the chamber where the V-notch is located (to avoid confined space entry issues), and to allow for installation of

portable continuous-flow measurement and recording equipment without the need to enter the chamber.



Lagoon Outlet Weir

4.6.25 **Shape**

The shape of all cells shall be such that there are no narrow or elongated portions. Anaerobic lagoons can be square or rectangular. Aerated cells can be square if they are in a multi-celled aerated lagoon system (i.e. more than one aerated cell followed by a polishing cell). Otherwise, both the facultative and aerated cells shall have length to width ratios of 2:1 to 4:1. No islands, peninsulas or coves shall be permitted. Dykes shall be rounded at the corners to minimize the accumulation of floating materials. Common-wall dyke construction wherever possible is strongly encouraged.

For very small lagoons with special configurations, installation of aeration equipment shall provide for positive control of short-circuiting through the lagoon.

Cell volume may be calculated with equation 4-12.

$$V = \frac{d}{6} \times (A_t + A_b + 4A_m) \quad (4-12)$$

Where

$$A_t = L \times W$$

$$A_b = (L - 2ES \times d)(W - 2SS \times d)$$

$$A_m = (L - ES \times d)(W - SS \times d)$$

V = Volume (m³)

d = depth of the cell (m)

A_t = Area of the top of the cell (m²)

A_b = Area of the bottom of the cell (m²)

A_m = Area of the midsection of the cell (m²)

SS = slope of the sides of the cell (run/rise)

ES = slope of the ends of the cell (run/rise)

L = Length of the top of the cell (m)

W = Width of the top of the cell (m)

4.6.26 **Berms**

- 1) The top of berm elevation shall be 600 mm above the one in 200-year flood return elevation.
- 2) For multicelled systems, embankment tops shall have a minimum width of 4.0 m to permit safe access of maintenance vehicles.
- 3) All topsoil shall be stripped from the area on which the berms are to be constructed.
- 4) Embankment slopes should be as steep as the safe operation of equipment will permit and the local soil condition will allow. Slopes of 4:1 (horizontal:vertical) on outer slopes are recommended to safely allow grass mowing; inside berm slopes shall be no steeper than 3:1;
- 5) The vertical distance between the high water or ice level and the top of the berm shall be a minimum of 0.3 m with ice build up and 0.6 m without ice. Increased 'freeboard' may be required where high winds and steep embankments result in water scouring; For storage lagoons, a minimum freeboard shall be 1 m.
- 6) Material used shall be selected fill compacted to 95% Standard Proctor Density in 150 to 200 mm lifts. The seepage rate shall be less than 5.2×10^{-9} m/s under maximum operating liquid depth.
- 7) Soil conditions may require the berm(s) to be "keyed" into the subsoil to preclude the horizontal seepage across the base of the berm.

4.6.27 **Surface Treatment**

Minimum protection by mulch seeding on 100 mm topsoil layer for all surfaces not normally underwater shall be applied.

Where cells will be empty for a long period before filling, the entire berm surface shall be mulch seeded to prevent erosion.

The cell bottom shall be level and flat (± 150 mm), or to within tolerances required by the aeration equipment manufacturer.

4.6.28 **Servicing**

Provision shall be made to facilitate servicing aeration units in place and to remove aeration units from their location for servicing.

4.6.29 **Maintenance Facilities**

Hosing and cleaning equipment to maintain sanitary conditions shall be provided.

4.7 MECHANICAL SECONDARY TREATMENT PLANTS

The use of simple and robust technologies such as stabilization lagoons is preferred for secondary treatment where site conditions allow. However, in cases where space limitations or other site-specific factors make the use of lagoons impractical or otherwise undesirable, mechanical secondary treatment facilities including rotating biological contactors, trickling filters, activated sludge processes and combinations or variants of these may be used. Where mechanical secondary treatment works are used, robust processes that are reliable and simple to operate are preferred. Refer to Policy Statement #2.



Typical Mechanical Wastewater Treatment Plant

4.8 WETLANDS AND AQUATIC SYSTEMS

Wetlands and aquatic systems may be used where these are identified in the Feasibility and/or Pre-design Reports.

Wetlands and aquatic systems are passive natural or engineered systems that rely on aquatic flora and fauna to treat wastewater. Wetlands and aquatic systems can potentially be used for wastewater treatment as well as for reuse of treated effluent. Refer to Policy Statement #2.

4.8.1 Constructed Wetlands

Constructed wetlands use natural aquatic plants and organisms to improve water quality and can also serve as a wildlife habitat. These systems may include free surface wetlands, subsurface-flow wetlands, floating aquatic plant systems or a combination of these.



Constructed Wetland

4.8.2 **Natural Wetlands**

Where reclaimed water is to be used to maintain natural wetlands, the criteria set out in the B.C. Municipal Sewage Regulation (MSR) for reclaimed water or any future Federal/Provincial updates shall be followed. A copy of the MSR and its associated guidance documents can be obtained from the B.C. Ministry of Environment (see Appendix VI) for Agency contact information. Care must be taken to address the impact on the natural ecosystem.



Wetland

4.9 SOLIDS HANDLING, TREATMENT, AND DISPOSAL OR BENEFICIAL USE

The Phase 1 Feasibility Report shall include proposed strategies for long term handling, treatment and disposal or beneficial use of waste solids generated by wastewater treatment.

If untreated waste solids are to be transported offsite for treatment or disposal elsewhere, the destination treatment or disposal facility shall be identified, and design information shall be presented to show that the offsite treatment facility can accept the additional waste solids. The owners of the offsite facility shall also be contacted to determine whether or not they are willing to accept the additional waste solids on a long term basis, and clearly define the acceptable quality of waste solids that they will accept.

If waste solids are to be treated onsite, the proposed approach and method(s) of treatment shall be included in the concept designs and cost estimates (Feasibility Report and Pre-design Report). The Phase 1 Feasibility Report analysis shall include all proposed unit processes such as sludge thickening, digestion, and dewatering of treated biosolids where applicable.

Where beneficial use of treated biosolids is proposed (e.g., land spreading, composting, topsoil manufacture), the B.C. Organic Matter Recycling Regulation (OMRR) or any future updates shall be used to determine solids treatment requirements, as well as requirements and limitations for beneficial use. The OMRR requires that a Land Application Plan be prepared by a “Qualified Professional” before land spreading of biosolids can be undertaken. A copy of the OMRR and its associated guidance documents can be obtained from the B.C. Ministry of Environment (see Appendix VI for Agency contact information).

For any land application of biosolids, environmental monitoring and reporting are required. The environmental monitoring program is normally prepared as a component of the Land Application Plan. The environmental monitoring program shall also be included in the environmental assessment and in the Operation and Maintenance Manual.

Where land spreading of biosolids is proposed, the development of a Land Application Plan need not be completed as a component of the Phase 1 Feasibility Report. However, for the Phase 1 Feasibility Report, if beneficial biosolids use is proposed, the beneficial use site(s) shall be identified, a preliminary analysis shall be conducted to assess the technical and environmental feasibility of the proposed application (land spreading, composting, topsoil manufacture, etc.), and site owners shall be contacted to determine whether or not they are willing to support biosolids use on their property. The estimated costs of beneficial biosolids use (preparation of Land Application Plans, transportation, land spreading, etc.) or disposal (e.g. tipping fees for landfilling) shall be included in the overall cost estimates for the concept designs developed in the Phase 1 Feasibility Report. This may be further developed in the Phase 2 Feasibility Report if appropriate. If land application of biosolids is proposed, a Land Application Plan shall be included as a component of the Pre-design Report.

PART 5 – COLLECTIVE GROUND DISPOSAL SYSTEMS

5.1 GENERAL

- 1) Ground disposal systems can be used where conditions allow percolation of wastewater effluent from a septic tank or treatment plant into the ground.
- 2) Approaches and requirements for the design of ground disposal systems are identified in Policy Statement #3. Contact information for obtaining copies of the regulations and accompanying guidance documents are included in Appendix VI.
- 3) Site evaluations and design of ground disposal systems shall be conducted by a specialist specifically qualified and trained in soil identification, hydrogeological and biochemical principles.
- 4) Ground disposal systems are commonly designed using absorption trenches, with each trench separate from the other and each containing a distribution pipe. This type of system shall be used whenever practical. Other types of absorption systems may be used as alternatives where the site conditions warrant and where conditions meet the specific design requirements of such alternative systems (see Policy Statement #3).
- 5) The design flows for residential ground disposal systems shall be based on the design flows calculated as set out in Section 4.2. For collective systems, infiltration and inflow must be added. Allowances shall be made when higher flows are expected.
- 6) Detailed design criteria shall be adopted according to the Policy Statement #3.

5.2 SITE EVALUATION and SEPARATION DISTANCES

Information concerning soil and site conditions is needed for proper design of liquid waste treatment and disposal facilities.

5.2.1 Evaluation of Soil and Hydrogeological Factors

Hydrogeological investigations including soil profiles, groundwater observations, soil hydraulic conductivity, percolation tests, and soil analyses shall be carried out by a qualified specialist for all proposed ground disposal systems.

5.2.2 Soil Profile and Site Investigations

The number of soil and groundwater profile test holes and percolation test holes will be dependent on site conditions and shall be determined by the qualified specialist.

A topographic map showing location and elevations of all test holes and percolation holes shall be prepared to accompany data submitted to INAC.

The factors listed below shall be addressed and, where applicable, evaluated and reported to a minimum depth of 1.0 m below the proposed absorption system (i.e., below the bottom of the trench, etc.). The actual depth of investigation required shall be determined on-site by the qualified specialist and is dependent on the soil and groundwater conditions, proposed depth of distribution pipe, and complications encountered on-site.

- 1) Thickness of soil layers or horizons
- 2) Texture of soil layers
- 3) Structure of soil
- 4) Soil chemistry
- 5) Hydrogeological factors including the following:
 - a) Hydraulic conductivity:
 - i. estimated by percolation tests*
 - ii. estimated through soil permeability and texture data**Note i) and ii) should correlate or the most conservative of the two should be used.
 - b) groundwater mounding effect (i.e. height and horizontal limits);
 - c) capillary rise;
 - d) groundwater gradient and velocity (speed and direction of wastewater flow in the ground);
 - e) discharge or exit point from the ground sub-surface to the ground surface or surface waters;
 - f) potential impacts (physical, human health, environmental) on the groundwater or surface waters; and
 - g) absorptive capacity of soils.
- 6) Depth to and characteristics of limiting layers; i.e. type of rock or soil with percolation rate slower than 60 min/25 mm,
- 7) Depth to groundwater and to estimated high water table,
- 8) Soil colour patterns (mottling) (used to indicate high water table elevation),
- 9) Intrusion of surface and/or groundwater into the proposed disposal areas,
- 10) Climate (e.g. precipitation and evaporation),

11) Physical site factors include the following:

- a) slope;
- b) landscape position (shape and direction of contours - i.e. convex, concave landscape); and
- c) setback distance requirements.



Test Pit for Ground Disposal

5.2.3 **Effluent Quality Classification**

Effluent quality classifications are set out in Table 5-1.

TABLE 5-1
EFFLUENT CLASS DEFINITION¹

Effluent Class	Description	Effluent Quality Parameters (maximum values) ²				
		CBOD ₅ (mg/L)	TSS (mg/L)	Fecal Coliform (number of fecal coliform organisms/100 mL)	Turbidity (NTU)	Nitrogen (mg/L)
A	High quality secondary (drinking water well within 300 m)	10	10	Median 2.2 any sample 14	Average 2 any sample 5	Nitrate-N 10 total N 20
B	High quality secondary	10	10	³	N/A	N/A
C	Secondary	45	45 ⁵	N/A ⁴	N/A ⁴	N/A ⁴
D	Typical septic tank	N/A ⁴	N/A ⁴	N/A ⁴	N/A ⁴	N/A ⁴

¹ Adopted from B.C. Municipal Sewage Regulation (1999), Schedule 4.

² Continuous effluent quality monitoring required for Class A and Class B.

³ A fecal coliform limit of 400/100 mL applies to discharges designed to meet the requirements of Row 2 and Column 4 to Table 5-3.

⁴ N/A means not applicable.

⁵ For lagoon systems the maximum TSS level must not exceed 60 mg/L.

5.24 **Horizontal Separation**

- 1) The horizontal separation distances shown in Table 5-2 are minimum values for collective ground disposal systems designed for flows from five or more house connections or for flows of 9,100 L/day or more from non residential facilities. Greater horizontal offset distances may be required depending on the hydrogeological impact study.

TABLE 5-2
MINIMUM HORIZONTAL SEPARATION REQUIREMENTS
FOR COLLECTIVE GROUND DISPOSAL FIELDS¹

Feature	Minimum Setback Distance	
	Maximum Daily Flow	
	Collective systems of <37 m ³ /d	Collective systems ≥37 m ³ /d
Property Boundary	3 metres	6 metres
Building Drain ²	5 metres	10 metres
Surface Water	30 metres	30 metres
Surface Water within Okanagan Basin	30 metres	150 metres
Water Well	60 metres	90 metres
Water Well within an Unconfined Aquifer	60 metres ³	300 metres ⁴

¹ Adopted from B.C. Municipal Sewage Regulation (1999), Schedule 7.

² The wastewater treatment facility itself is to be considered as a building.

³ Based on a hydrogeological assessment to determine the minimum distance required to protect water quality of the water well distance from water well must be extended accordingly.

⁴ Based on a hydrogeological assessment conducted by a Qualified Professional to determine the minimum distance required to protect water quality of the water well, the distance from the water well may be reduced or extended. In no case shall the distance be less than 90 metres.

2) Notwithstanding the setbacks set out in Table 5-2, a 15 m minimum setback to a property boundary, building drain, driveway, or other subsurface obstructions on the downgradient side of a built-up mound system is required.

3) In general, hydrogeological data shall be used to estimate effluent travel time from disposal point to break out point. The estimated travel time shall be compared to the following objectives:

- a) greater than 40 day effluent travel time from disposal field to recreational waters; and
- b) greater than 100 day effluent travel time from disposal field to waters used as a potable water source.

4) Ground disposal systems for septic tank effluent shall not be constructed in soils where rapid percolation may result in contamination of water-bearing formations or surface waters. Percolation rates less than 2 min/25 mm are too high for adequate renovation, and disposal fields are not recommended unless

hydrogeological studies show no adverse impact on groundwater quality at the property (see footnotes from Table 5-5).

5.2.5 Vertical Separation For Ground Disposal Systems

- 1) Ground disposal systems shall be located on the property to maximize the vertical separation from the bottom of the disposal field to the 1 in 20-year flood groundwater level, highest groundwater mound, bedrock, or other limiting layer. Under no circumstances shall this vertical separation be less than the distances set out in Table 5-3. Where water-bearing formations are in danger of contamination, greater vertical separation may be required. Deviation from this requirement shall be technically substantiated.

The need for this requirement is two fold. First, there is the need to protect surface and subsurface water supplies and recreation surface waters from contamination. Second, there is the need to ensure the longevity of the disposal trench by ensuring the trench infiltrative surfaces are maintained in an unsaturated aerobic zone within the soil matrix. The unsaturated zone is that zone above the capillary rise front elevation of the seasonal high groundwater table. In fine sands with typical percolation rates of 1 to 10 min/25 mm, the height of capillary rise is typically 430 mm; in coarse silts (i.e. sandy-silts, gravelly-sandy-silts) with typical percolation rates of 10 to 20 min/25 mm, the capillary rise is typically 1.05 m; in fine silt soil matrices with typical percolation rates of 30 to 60 min/25 mm, the capillary rise is typically 1.2 to 1.5 m.

- 2) The vertical separation between the bottom of the ground disposal trench, infiltration basin, etc. and the seasonal highest water table elevation including the groundwater mound created by wastewater disposal, shall be as set out in Table 5-3.

TABLE 5-3
MINIMUM VERTICAL SEPARATION REQUIREMENTS
FOR COLLECTIVE GROUND DISPOSAL FIELDS¹

Effluent Class	Drainage Pipe Length ⁴	Minimum Unsaturated Soil Depth ² (m)		Continuous Monitoring Required
		Design Flow <37 m ³ /d	Design Flow ≥37 m ³ /d	
A ³	Table 5-5	0.5	0.5	Yes
B ³	Table 5-5	0.5	0.5	Yes
C	Table 5-5	0.75	1.0	No
D	Table 5-5	0.75	1.0	No

- ¹ Refer to Table 5-1 on effluent class.
- ² Measured from the trench bottom to the highest water table including the groundwater mounding effect or restrictive layer where, in this note “groundwater mounding effect” means the vertical rise in the water table that occurs in response to a discharge.
- ³ Use of a drainfield in this category requires filtration to prevent solids carrying over into the disposal field. Monitoring controls must be maintained to signal an alarm when filtration begins to malfunction.
- ⁴ Use of chamber distribution systems with equivalent length are permissible. The bottom of the sidewall or “foot” of the chamber is considered to be the trench bottom.

5.3 ABSORPTION TRENCHES

5.3.1 General

- 1) The absorption trench gives additional treatment to the wastewater from the treatment tank. The satisfactory operation of the wastewater disposal system is largely dependent upon the proper site selection, design, and construction of the absorption trench, and proper design and maintenance of the septic tank. Typical absorption trench diagrams are given in Figure 5-1.
- 2) The maximum length of any one trench shall be 30 m for gravity systems. The maximum length of distribution piping in one absorption field shall be 300 m.

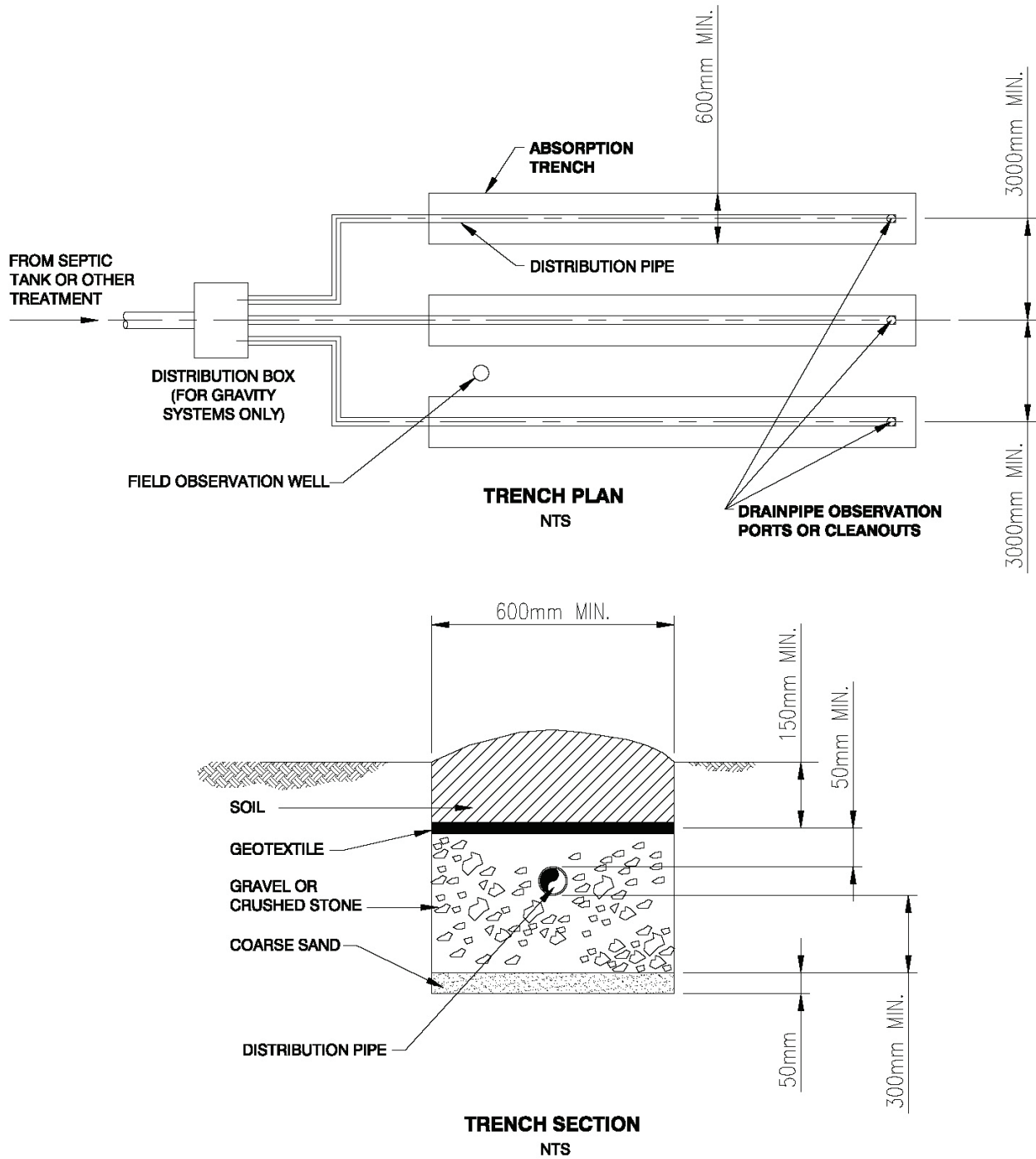

Figure 5-1 – Typical Absorption Trench

- 3) Gravity fed or non-pressure dosed absorption field distribution lines shall be not less than 75 mm in diameter and shall have the perforations at least 12.7 mm and no more than 19 mm in diameter and be spaced to provide at least 2% total opening area.

- 4) Absorption trenches shall have a minimum on-centre spacing of 3.0 m. Trench bottom width shall be a minimum of 0.6 m. Trench bottom shall be at least 0.3 m below the drain pipe invert. Soil pipe cover shall meet local frost protection requirements and shall not be less than 0.15 m.
- 5) Pressure dosed distribution pipe shall be 30 mm to 50 mm nominal diameter, minimum orifice diameter shall be 5 mm and minimum orifice spacing shall be 60 cm. Orifice spacing shall result in 0.56 m² of soil absorption area per orifice in the squarest dimension possible. Orifices may be positioned on top of the laterals with an orifice shield or they can be positioned downward on the bottom of the laterals. In cold climates the system shall drain after each dose to avoid freezing. All joints and connections shall be solvent cemented. The distribution network shall be designed to allow periodic flushing of the laterals. The pressurization unit can be either a pump or a siphon. An equivalent design that assures uniform distribution may be considered.

5.3.2 **Slope**

- 1) Gravity fed absorption field distribution lines and trenches shall be level or with a positive slope in the direction of flow not exceeding 50 mm per 30 m. Dosed absorption field distribution lines and trenches shall be level.
- 2) On rolling or sloping land, each absorption trench shall approximate the land surface contour.
- 3) It is preferred that absorption trenches not be installed on land with a slope greater than 12%. However, under certain soils and hydrogeological conditions trenches can be installed on slopes exceeding 12%. For slopes greater than 20%, the disposal field must be designed based on the specialist's investigation results and designed to allow for equipment access on the steep slopes, to ensure even distribution of effluent, and to avoid water hammer damage to pipes and anchorages.

5.3.3 **Lot Sizes**

- 1) Lot size for residential units for which ground disposal fields are proposed shall be determined by a Qualified Professional and be based on recommendations from hydrogeological investigations, set back requirements, INAC's Level of Service Standards, etc.

5.3.4 **Material**

- 1) Coiled perforated plastic pipe shall not be used when installing absorption systems. Straight lengths of pipe shall be used instead.
- 2) Pipe used for distribution lines shall meet the appropriate CSA or ASTM standard or those of an equivalent testing laboratory. Fittings used in the

absorption field shall be compatible with the materials used in the distribution lines.

- 3) Refer to Section 5.4.1(3) and (5) for perforation requirements.
- 4) Gravel or crushed stone shall be used as the bedding material and drain pipe cover and shall be washed and screened and contain less than 5% fines and shall range in size from 20 mm to 50 mm.
- 5) The material used to cover the top of the stone shall be non-biodegradable, breathable, geotextile material or equivalent (e.g., untreated building paper). Use of other material must be well justified. Plastic film or treated building paper shall not be used.

5.3.5 **Drainage Pipe Length**

Minimum drainage pipe lengths for ground disposal systems are set out in Table 5-5.

TABLE 5-5
MINIMUM DRAINAGE PIPE LENGTH¹

	Number of metres of drainage pipe for each 10 m ³ /d of Maximum Daily Flow for percolation rates shown						
Percolation rate; minutes/25 mm	2 ^{2,3}	5 ²	10	15	20 ⁴	25 ⁴	30 ⁴
Effluent Class Prior to Application: A, B or C	50	75	100	110	120	135	150
Effluent Class prior to Application: D	120	215	280	320	360	400	430

¹ from B.C. Municipal Sewage Regulation (1999), Schedule 4.

² for discharges equal to or greater than 37 m³/d only, if the soils are well drained and if the depth to groundwater including any groundwater mounding effect is greater than 1.0 m below the bottom of the drainage trench, a Qualified Professional may design the ground disposal system with deeper narrower trenches and the drainage pipe length may be reduced to a value equal to the product of Table 5-5 pipe length and a factor of 1/H^{0.5} or 0.8 (whichever factor is greater), where H is the drainage trench depth below pipe invert in metres.

³ percolation rates less than 2 minutes per 25 mm are too fast for adequate renovation and drainfields will not be permitted, unless hydrogeological studies show that local groundwater quality can be met at the property boundary. For discharges of less than 37 m³/d only, use of AMERICAN SOCIETY OF TESTING MATERIALS C33 sand mounding or AMERICAN SOCIETY OF TESTING MATERIALS C33 sand-filled trenches to reduce percolation is permitted if Class B or A effluent is discharged by pressure distribution.

- 4 percolation rates more than 20 minutes per 25 mm require the construction to be supervised by a Qualified Professional to have been carried out in a manner which has not reduced the trench wall permeability unless, for discharges less than 37 m³/d only, the native undisturbed permeable soil depth exceeds 1.35 m.

5.3.6 **Construction**

- 1) Ground disposal systems shall not be constructed in unstabilized or unconsolidated fill. Consolidation procedures for fill material shall be specified by a specialist who can technically substantiate the methodology.
- 2) A distribution box shall be installed between the septic tank and the absorption trenches except on pressure distribution systems where a header is used.
- 3) The distribution box shall be set level and arranged so that effluent is evenly distributed to each distribution line. Adjustable v-notch weirs or approved alternative system must be provided to overcome uneven distribution due to distribution box settling. Adequate provisions shall be taken to assure stability and provide easy location (e.g. use marker posts) and access for inspection of the distribution box.
- 4) Each distribution line shall connect individually to the distribution box for gravity systems.
- 5) The pipe connecting the distribution box to the distribution line shall be non-perforated and shall be of a tight joint construction and properly bedded throughout its length.
- 6) For pressure distribution systems, the header shall be of watertight construction and there shall be an equal number of distribution lines spaced evenly on both sides of the junction of the leader to the header.
- 7) Each distribution line shall be equal in length.
- 8) Although the trench design is based on bottom area, it is recognized that sidewalls are an effective infiltration surface and shall be maximized. When the trenches have been excavated, the sides and bottom shall be raked to scarify any smeared soil surfaces. The soil material raked shall be removed from the bottom of the trench. Over-excavated trenches shall be back-filled with coarse clean sand, gravel or crushed stone. Construction equipment not needed to construct the system shall be kept off the area to be utilized for the absorption trench system to prevent undesirable compaction of the soils. Construction shall not be initiated when the soil moisture content is high. (Note: If a fragment of soil occurring approximately 230 mm below the surface can easily be rolled into a wire, the soil moisture content is too high for construction purposes. The finished absorption area shall be graded so that rain or ground water can drain way from the site.

- 9) A 150 mm to 300 mm layer of gravel or crushed stone as defined in Section 5.4.4(4) shall be placed in the bottom of the trench on top of a minimum 50 mm layer of coarse sand.
- 10) The distribution line shall be carefully placed on the bedding at a uniform slope and covered with at least 50 mm of gravel or crushed stone as defined in Section 5.4.4(4).
- 11) Cover trenches with not less than 150 mm of soil or sod. Shallow bury may be considered in special circumstances.
- 12) Drain pipe observation ports shall be provided at the ends of perforated gravity or non-pressure dosing distribution lines and shall be capped and accessible from grade. Pressure distribution lines shall be provided with a capped cleanout access port, accessible from grade.
- 13) A 100 mm diameter inspection well shall be installed in the trench 100 mm from the distribution pipe, and shall extend from the trench bottom to above ground. The inspection well shall be perforated in the gravel portion of the trench with perforations beginning 50 mm below the distribution pipe discharge. Removable caps shall be installed on the wells.
- 14) The absorption area shall be seeded or sodded immediately after construction to prevent erosion.

5.4 DOSING

5.4.1 General

Intermittent dosing is recommended for all systems and shall be provided when the design wastewater flow requires more than 150 linear metres of distribution line. In addition to Policy Statement 3, when the design wastewater flow requires more than 300 linear metres of distribution line, each absorption field shall be divided into two equal portions and each half dosed alternately to the recommended frequencies described in Section 5.4.2.

5.4.2 Dosing Frequency and Volume

Dosing frequency may be on-demand or timed. Where timed design is used, the dosing tank volume shall be adjusted to store peak flows. Frequent small doses are generally preferred to large doses once or twice per day. However, dosing should not be so frequent that distribution is poor. In general, each dose volume shall not exceed 20% of the design daily flow. To promote uniform distribution in dosed systems, the duration of each discharge shall not exceed 15 minutes. The actual design time of discharge will depend on the size of disposal system, type of dosing system and dosing flow rate.

Long-term resting provided by alternating fields may be desirable for silty soils. Appurtenances shall be installed to facilitate isolation, resting and renovation of each of the two halves of the field.

5.4.3 **Methods of Effluent Dosing**

- 1) Recommended methods of effluent dosing for different soil percolation rates are shown in Table 5-4.

TABLE 5-4
RECOMMENDED METHODS OF EFFLUENT DOSING

Soil Permeability (Percolation Rate)	Recommended Methods of Effluent Dosing*
Very Rapid to Rapid (less than 10 min/25 mm) and more than 2 min/25 mm	Pressure Dosing Non-Pressure Dosing
Moderate to Slow (11 to 60 min/25 mm)	Gravity Distribution Non-Pressure Dosing Pressure Dosing

* Methods of dosing are listed below.

- u) **Gravity Distribution:** Wastewater flows from treatment unit directly into the absorption system. Distribution box is used.
 - v) **Non-Pressure Dosing:** Wastewater is dosed by pumping or siphon to ensure intermittent aeration (distribution box is used).
 - w) **Pressure-Dosing:** Wastewater is applied intermittently through a pressure distribution system (with no distribution box).
- 2) Dosing may be accomplished by either pumps or siphons. Each side of the system should be dosed to the recommended frequency in Section 5.3.2.
 - 3) In a system using pressure dosing, the size of the dosing pumps shall be selected to maintain a minimum pressure of 7 KPa (1 PSI) at the end of each distribution line.

5.4.4 **Pump Dosing**

Where dosing chambers are provided, they shall meet the construction requirements specified for septic tanks. The required volume of the dosing chamber shall not be considered as any portion of the required volume of the septic tank. Dosing chambers shall be provided with access ports sufficiently large to maintain the tank and pumps, and shall be vented. Where cold air draft into the dosing chamber is a concern due to freezing, a removable plug shall be attached to the vent. In case of pump failure, a high water alarm switch set above the design volume of the dose

shall be provided on a separate circuit from the pump, and have an audible or visible alarm. Pumps, control devices, and system installation within the dosing chamber shall be of an explosion proof design (see Section 3.6.3).

5.4.5 **Siphon Dosing**

A siphon dosing chamber can be used in place of a pump dosing chamber where head is available.

Tests by the Ontario MOE on alternating siphons have shown that one siphon may operate several times in a sequence before the second siphon is activated. Therefore, where alternating dosing of two segments of the field(s) is required, pumps rather than alternating siphons in a common chamber are recommended.

5.5 **DEEP ABSORPTION TRENCHES**

Deep absorption trenches may be considered where the depth of suitable soil is insufficient to permit the installation of a conventional trench system due to the presence of a limiting layer more than 600 mm in depth which overlies suitable soils of sufficient thickness. Requirements for separation distance, pipe and trench design, slope, lot sizes, material, construction and dosing system design as set out in Sections 5.3 and 5.4 for Absorption Trenches shall apply to deep absorption trenches except for the depth of trench. In addition, the following design considerations shall apply:

- 1) The site evaluation procedure shall include soil profile observations of at least three (3) soil observation pits constructed to a minimum depth of 900 mm below the proposed trench bottom. Monitoring to establish depth to seasonal soil saturation or high groundwater shall be considered. The possibility of groundwater contamination shall be considered.
- 2) The base of deep absorption trenches shall be at least 450 mm into the suitable soil.

5.6 **BUILT-UP MOUNDS**

5.6.1 **Design of Mound Systems**

Built-up mounds may be considered whenever site conditions preclude the use of absorption trenches or absorption beds. The construction of a mound shall be initiated only after a site evaluation by a specialist has been made and landscaping, dwelling placement, effect on surface drainage, groundwater mounding and general topography have been considered. Due to the nature of this alternative system, actual selection of mound location, size of mound, and construction techniques shall be carefully considered. Maintenance procedures are critical and must be incorporated in the Operation and Maintenance Manual as per Section 1.9.2.

Design of the mound systems shall follow Sections 5.1 through 5.4 with the following additional considerations:

- 1) Pressure distribution systems shall be used with all mound systems.
- 2) Mounds may be constructed using Absorption Trench construction standards (Section 5.3.1) and mounds (raised/elevated portion) must be constructed using American Society of Testing Materials C33 sand.
- 3) Mounds shall have a maximum height of 1 m with minimum vertical separation according to Section 5.2.5.
- 4) The distribution basal area must be level along length and width of the mound with the berm side slope beginning not less than 1 metre from outer edge of distribution lateral.
- 5) Berm side slope must be greater than 3:1 horizontal to vertical ratio.
- 6) Provide for an effluent infiltrative monitoring well and a down-gradient effluent sampling monitoring well.

5.6.2 **Location**

- 1) Built-up mounds shall not be utilized on sites which meet the definition for floodplain, poorly drained, very poorly drained, or stony soils.
- 2) Built-up mounds shall not be utilized on soils where the high groundwater level, bedrock, or other strata having a percolation rate slower than 120 minutes per 25 mm occurs within 600 mm of natural grade. Where rapid percolation may result in contamination of water-bearing formations or surface waters, built-up mounds shall not be utilized unless it can be demonstrated that risk of contamination is remote. Built-up mounds shall be constructed only upon undisturbed, naturally occurring soils.
- 3) Mounds shall be constructed perpendicular to the ground slope, following the contour.

5.7 GRAVELLESS AGGREGATE EFFLUENT DISPERSAL SYSTEMS

Gravelless systems or artificial aggregate systems offer alternatives to traditional pipe and gravel distribution. The use of gravelless technology has advantages in areas where aggregate is unavailable or very expensive; additionally these technologies may reduce installation costs.

Gravelless systems shall be designed by following Sections 5.3 and 5.4 with the following additional consideration.

- 1) Proprietary gravelless systems shall be:
 - x) designed according to good engineering practice and manufacturer's recommendations;
 - y) have a load bearing capacity not less than AASHTO H-10;
 - z) installed with consideration to manufacturer's instructions; and
 - aa) chamber systems shall have an effective side wall open area not less than 35% of bottom infiltrative area.
- 2) Synthetic aggregate systems shall:
 - bb) provide not less than the equivalent void space as a gravel aggregate system (not less than 35% void space); and
 - cc) withstand the pressure of backfill without distortion or compaction.

5.8 RAPID INFILTRATION BASINS

Ground disposal of effluent from community and/or industrial/commercial/institutional systems through the use of rapid infiltration basins may be considered where site conditions are shown to be suitable. A minimum of secondary treatment is required prior to ground disposal through the use of rapid infiltration basins. Refer to Section 4.1 and to the BC Municipal Sewage Regulation (see Appendix VI for contact information).

Rapid infiltration systems generally consist of a number of basins that are flooded then allowed to dry before they are flooded again. During the drying period organic matter that is collected on the soil decays. Hydraulic loading rates vary widely, and depend on soil type, depth to groundwater, effluent quality and other factors.

The relevant parts of Section 5.1 through 5.4 shall be followed for design.

5.9 SITE PROTECTION

All multiple housing/collective ground disposal systems, including tanks, distribution boxes, etc. should be surrounded by a physical barrier with warning signs to prevent damages by vehicles or other means.

5.10 DISPOSAL FIELD PROTECTION

- 1) It is important to prevent excess solids from entering the ground disposal system to minimize clogging. Regular inspection of the system and sludge removal is necessary, and schedule should be incorporated in the Operation and Maintenance Plan as per Section 1.9.3.
- 2) Grinder pumps discharging directly to disposal fields are not permitted.

PART 6 – OUTFALLS

6.1 GENERAL

The extent of works required for outfalls is not necessarily limited to the items noted in this section. Outfall works require specialized fields of expertise and the user is referred to the Foreword Section as a reminder of the Qualified Professional's responsibilities. The outfall shall be designed by a Qualified Professional specialized in the specific discipline. Outfall works shall meet the requirements of the B.C. Municipal Sewage Regulation as well as applicable Federal requirements (see Policy Statement #4 and Appendix VI for Agency contact information). A checklist of items for pre-design studies and design of outfalls for domestic wastewater disposal is presented below. No allowance has been made for the impact of industrial discharges. All agencies having a vested interest in the project shall be contacted to ensure that their concerns are considered. Necessary easements and permits shall be obtained from Federal, Provincial and private agencies before commencing construction of the outfall.

Consideration shall be given in each case to the following:

- 1) dispersion methods: (limited or complete across stream dispersion) as needed to protect aquatic life movement and growth in the immediate reaches of the receiving stream;
- 2) hazards to navigation;
- 3) potable water intakes in the receiving water system which could be impacted;
- 4) recreational areas which could be impacted;
- 5) nutrient loading on the receiving waters which could contribute to or create a eutrophication problem; and
- 6) potential impacts on aquatic species.

6.1.1 Effluent and Environmental Monitoring

All outfalls shall be designed so that a sample of the effluent can be obtained at a point after treatment and before discharge to the receiving waters.

Receiving water quality monitoring requirements shall be considered in the Feasibility Report, detailed in the Pre-design Report and summarized in the Design Report.

6.1.2 **Structural and Operational Integrity**

The outfall shall be constructed and protected against such effects as floodwater, wave action, currents, erosion, corrosion, etc. to reasonably ensure the structural integrity and to ensure against plugging or flow stoppage.

A manhole or clean-out shall be provided at the shore end of the outfall.

6.1.3 **Location and Depth**

- 1) Location shall be determined through site-specific conditions.
- 2) Land features (e.g. points of land, embayed areas), bottom contours, winds, currents, and water depths shall be taken into consideration when locating an outfall.
- 3) Location and design shall be determined to ensure optimum use of available dilution. Use of depth and diffuser design are prime considerations in this regard.

6.1.4 **Initial Dilution Zone: Water Bodies**

If effluent is discharged into a water body, the initial dilution zone is the three dimensional zone around the point of discharge where mixing of the effluent and the receiving water occurs. The requirements for initial dilution zones set out in the B.C. Municipal Sewage Regulation and the Canadian Council of Ministers of the Environment (CCME) guidance documents. These requirements or any Federal/Provincial updates whichever is more current shall apply (see Appendix VI for Agency contact information).

6.2 *FEASIBILITY REPORT*

Alternatives for proposed outfall discharges shall be evaluated in the Feasibility Report (see Section 1.2). In addition, the Feasibility Report shall include the following items:

- 1) Identify the nature and extent of the disposal problem
- 2) Review data (if available) on the existing wastewater system for:
 - dd) wastewater flows
 - ee) degree of treatment
 - ff) effluent quality
 - gg) pipe-invert elevations

hh) location relative to tide elevations

ii) present condition

- 3) Acquire and review the development plan for the area for:
 - jj) ultimate growth populations
 - kk) future land use which would impact placement of facilities
 - ll) ultimate configuration of wastewater treatment and disposal system most suited to ultimate development
- 4) Obtain and review the existing hydrologic, oceanographic and meteorological data for the proposed site as pertinent.
 - a) Hydrological Data.

If the proposed outfall is at or near the estuary of a major river, seasonal variations in fresh water influx will impact the characteristics of a wastewater plume.
 - b) Meteorological Data.

In remote areas, river flows may not be monitored. If outfalls are proposed at or near estuaries where there are no hydrological records, meteorological records in the area will provide insight to possible seasonal variations in stratification
 - c) Oceanographic Data.

Historical records of stratification and currents are often available through the Institute of Ocean Sciences or the University of British Columbia for a great deal of coastal B.C. If data are not available in the immediate area of interest, there may be data available for areas of similar characteristics which can be transposed for the purpose of initial evaluation. Marine charts and topographic mapping shall also be obtained to provide the investigator with the physical characteristics of the site.
- 5) Site investigations as may be practical to augment and validate items identified above. In most cases a preliminary evaluation of a site can be made with the available mapping and historical data only. Where necessary data are lacking, a Phase 2 Feasibility Report may be needed for assessing outfall options (see description of Phase 1 and Phase 2 Feasibility Reports, Section 1.2). If the project site is easily accessible the investigator should make every effort to visit the site and evaluate the logistics of constructing an outfall at the site.
- 6) Present alternative methods of solving the problem, complete with conceptual designs and comparison of costs, advantages and disadvantages. On the basis of the study area characteristics as determined from historical information (or from fieldwork if carried out as a component of a Phase 2 Feasibility Report) and

extrapolated for seasonal variations, develop one or more conceptual designs for a treatment and disposal system. This conceptual design shall address the impact of various levels of treatment on the construction of the outfall. The conceptual design of the outfall for the preferred combination shall specifically address the following:

- a) Proposed outfall route, complete with profiles extracted from available marine charts;
 - b) Probable current patterns in the vicinity of the terminus as interpolated from costal geometry;
 - c) Depth and nature of proposed terminus;
 - d) Configuration to complement treatment and disposal system;
 - e) Location of environmentally sensitive areas (beaches, shellfish areas, fish spawning areas, water intakes) from historical reference material or discussion with local fisheries officer;
 - f) Probable protection measures required;
 - g) Hydraulic constraints (tide elevations relative to discharge);
 - h) Probable construction material and special concerns (eg. weighting of polyethylene pipe); and
 - i) Class C estimate of anticipated construction and operation and maintenance costs.
 - j) Water quality requirements at the “end of pipe” to meet requisite receiving environment criteria. This shall be determined through preliminary dilution analysis as identified in article 8.
- 7) Some environmental parameters may vary with tides and/or seasons. If a project is large enough, or of a particularly sensitive nature, environmental investigative programs may have to extend to observe the seasonal variation. If the most unfavourable condition can be identified from the feasibility study, the investigation may be limited to that condition.

Due to budgets or time constraints, the prediction of outfall performance is often based on oceanographic data collected over a one week or month period. Since environmental conditions vary seasonally, the degree of seasonal variation in parameters such as winds, currents, temperatures and salinities must be estimated. A sensitivity analysis shall be conducted to predict the impact of seasonal variation assumptions on the performance of the outfall. By estimating minimum, maximum and probable values for the parameters, the boundary conditions or performance levels can be calculated. This is particularly important where the predicted water quality forms the basis for selecting the preferred treatment and disposal option.

- 8) The performance of the outfall alternatives developed in the conceptual design shall be evaluated in terms of the following:
- a) initial dilution;

- b) secondary dilution due to dispersion;
- c) bacterial die-off;
- d) predicted receiving water quality at sensitive areas; and
- e) effluent plume travel path.

Initial dilution predictions can be made with numerical models as discussed in reference texts such as "Mixing in Inland and Coastal Waters" (Fischer et al., 1979), by Academic Press. Alternatively and preferably, initial dilution predictions can be made with the computer models developed by the United States Environmental Protection Agency (USEPA). A synopsis of the available models, their mechanics and their applications are enclosed in Appendix IV of these guidelines.

Secondary (far field) dilution predictions should be made using the computer models or methods of Brooks as discussed in "Wastewater Engineering", Metcalf and Eddy 1991), or "Mixing in Inland and Coastal Waters", referred to previously.

Bacterial die-off predictions should be made using the pure death equation as discussed in the previous mentioned reference texts.

Investigators shall endeavor to evaluate a "worst case" scenario in terms of surfacing plume and shortest probable time of travel to sensitive areas. Selection of data for input into the programs is critical as even minor variations can create over optimistic predictions. It is strongly recommended that a specialist in the field of outfall design and evaluation be retained for this component of the work.

The dilution modeling is used to develop predictions of water quality at sensitive areas or at locations downstream of the outfall. These should be developed in light of the local current patterns, and reported in the Feasibility Report.

- 9) Present in preferential order the options that will solve the problem in a cost effective and environmentally acceptable manner.
- 10) Include in the Feasibility Report the following information specific to outfall discharges:
 - a) Existing and proposed populations and anticipated wastewater flows
 - b) Synopsis of site characteristics as identified by oceanographic and geographic data.
 - c) Limitations of available data and additional items to be gathered in site specific investigations which would impact selection of wastewater disposal options.
 - d) Wastewater outfall discharge options, complete with cost estimates, statement of applicability and potential environmental impacts.

- e) Recommendations for preferred course of action on the basis of the available data; additional data to be gathered to confirm recommendations; and site specific data to be gathered to enable detailed design.
- f) Requirements of studies to address any unusual or technically difficult features of the proposed site.
- g) Pre-discharge and post discharge environmental monitoring requirements.

Use of information gathered in the literature search and investigation for the conceptual design should be used to assist the Qualified Professional in designing and optimizing the field program for the Pre-design Report.

6.3 PRE-DESIGN REPORT

6.3.1 Previous Studies

All relevant literature, including oceanographic reports feasibility and conceptual design reports, etc., must be summarized in the Pre-design Report to make the report a 'stand-alone' document.

6.3.2 Field Work

The field work is a major component of the Pre-design Report for outfalls. Because of the remote nature of many of the projects, the Qualified Professional shall spend sufficient time to gather all of the data needed for design. Data shortfalls and resources will have to be identified in the Feasibility Report.

For outfall projects, field work shall include a physical inspection of the proposed route. Every effort shall be made to make the information gathered by divers as quantitative as possible. All diving work must comply to Workman's Compensation Board Regulations, and shall have a minimum of 3 WCB certified divers. Ideally the dive team will also include a technician or Engineer knowledgeable in outfall design and a marine biologist capable of identifying sensitive or commercially viable species in the area of the proposed outfall.

6.3.3 Design Criteria

The Pre-design Report shall list the design criteria to be satisfied by the proposed installation. Reference to current federal standards and to the B.C. Municipal Sewage Regulation and its associated Guidance Documents shall be made where applicable. Specifically the report shall address the following:

- a) minimum water quality necessary to meet water use activities (e.g. swimming) and habitat requirements (e.g. shellfish harvesting, kelp harvesting, herring roe harvesting, etc.);

- b) minimum effluent quality required to attain the desired receiving water quality objective outside the initial dilution zone;
- c) minimum treatment requirements;
- d) the quantity and quality of the effluent to be discharged – specifically the report shall address per capita flow (domestic effluent and infiltration/inflow); peak design flow (as prescribed by accepted engineering practice or dictated by reviewing agencies having site specific knowledge); and the effect of the treatment system on the outfall hydraulic loading (some treatment systems will affect the peak discharge flows).
- e) an outfall must be designed and located to ensure that the discharge does not cause water quality parameters outside the IDZ to exceed water quality standards relevant to the location. In addition, an outfall diffuser should be designed and located
 - i. at a sufficient depth to maximize the frequency that trapping of the effluent below the surface of the water body occurs,
 - ii. to intercept the predominant current and avoid small currents that tend to move in toward the shore,
 - iii. in the channel in which most of the water of the river or stream flows to achieve maximum dilution;
 - iv. in the thalweg of the river or stream to minimize the risk of shoreline contact.
- f) an outfall must meet the depth, flow and distance standards set out in the B.C. Municipal Sewage Regulation or any Federal/Provincial updates (see Appendix VI for Agency contact information);

6.34 **Environmental Assessment Study**

The environmental assessment study must be carried out through site specific investigations by the Qualified Professional with assistance from specialists as required (oceanography, biology or geotechnical). The study goal is to predict the impact of the construction and operation of the outfall on the stated environmental parameters. Refer to INAC's Practical Guide for Capital Projects titled "General Terms of References for Environmental Assessment" and "A Summary of the Environmental Screening Process for First Nations Capital Projects" (see Appendix I). Specialists in the following areas should be involved under the co-ordination of the Qualified Professional.

1) Oceanography

Physical and chemical oceanographic parameters which shall be considered for investigation are as follows:

- a) surface and subsurface current studies using moored meters and drift equipment;
- b) wave studies (estimated from historical meteorological data and fetch);
- c) tides (use tide tables - tides in B.C. are well known);
- d) conductivity or salinity profiles;
- e) temperature profiles;
- f) meteorological information;
- g) hydrographic information;
- h) dissolved oxygen; and
- i) condition of the bottom along the proposed route in the area of the terminus of the outfall.

Both moored meter and drift studies are usually necessary and the balance of use between the two shall be substantiated in the Pre-design Report. The proposed Pre-design investigation shall specify the duration and location of the moored meter and drift studies. Generally, it is better to track a number of drogues with different start times, than to track only a few over a long time.

The oceanographic study shall be designed to confirm the worst case hydrographic condition.

2) Biology

The marine species, or their use, affected by the proposed outfall shall be determined. Relevant biological information may include:

- a) Bacteria/Viruses - total and fecal coliform concentrations in water column, sediment and shellfish/fish tissues shall be used as indicators for pathogenic organisms;
- b) Benthos (including algae/plants & intertidal/subtidal) species composition, abundance and distribution zonation patterns present and potential recreational and commercial utilization importance;
- c) Fish - species composition, abundance and distribution migration patterns and routes nursery and holding areas present and potential recreational and commercial utilization and importance rearing areas and habitat.

3) Geotechnical

Where there are specific concerns with regard to foundation or bed stability, a geotechnical engineer must be involved. Characteristics which flag the need of these specialists are as follows:

- a) deep, soft sediment;
- b) movable base material;

- c) requirement for pipe burial, identify;
- d) stability of trenches;
- e) sub-bottom rock;
- f) possibility of soil liquefaction; and
- g) steep slopes (submerged face of deltaic fans, alluvial or talus slopes).

6.3.5 **Environmental Monitoring**

The purpose of undertaking a monitoring program during the Pre-design stage is to establish a baseline upon which subsequent post-discharge can be compared and determine the influence of shoreline contamination sources. Statistical design is critical to optimizing the information obtained and minimizing program costs.

As public health is the principal concern, coliform analysis of water, shellfish tissue and sediment samples shall be considered. Water samples shall be collected at representative locations and depths at offshore stations to establish background coliform concentrations and identify the influence of existing sources of contamination in the area. Samples shall be collected at each station throughout the tide cycle to establish diurnal variation patterns. The location of the sample stations must be identified with GPS and depth. Tide level at the time of sampling must be recorded.

A minimum of 3 water quality sampling sites are required as follows:

- a) Reference station outside the influence of the discharge;
- b) Within the IDZ over the outfall terminus;
- c) At the downstream edge of the IDZ.

An assessment of potential shoreline sources includes the following:

- a) septic tank ground disposal systems;
- b) creeks;
- c) storm drains and drainage ditches;
- d) agricultural run-off;
- e) marinas (boat discharges); and
- f) landfill seepage or run-off.

The shoreline sampling shall be made in conjunction with offshore sample collection. Monitoring shall take place during worst-case hydrographic conditions. All water samples shall be assessed for both total and fecal coliform concentrations.

As an adjunct to water quality sampling, representative shellfish tissue samples and sediment samples shall be collected in the vicinity of the proposed outfall terminus and in identified shellfish beds in the general area. While sediment samples are analyzed for both total and fecal coliform concentrations, tissue samples will be

assessed for fecal concentrations only. Where the nutrients being discharged represent a significant proportion of the tidal flux nutrient load, samples shall be collected for nutrient analysis. Physical oceanographic characteristics under which nutrient loading may be a problem include poor circulation or possible embayment conditions.

In environmentally sensitive areas, additional monitoring may be required to supplement the monitoring data collected under this section.

6.3.6 **Reporting**

The Pre-design Report must be a stand-alone document presenting the details of items listed in Section 6.3.1 through 6.3.5, complete with Class B cost estimates for the preferred disposal options (see Appendix II), life cycle costs and identification of potential design, construction and operational problems. This document must be of sufficient detail to support an application for registration under the B.C. Municipal Sewage Regulation and shall meet applicable federal legislation, standards and guidelines.

6.4 DETAILED DESIGN

6.4.1 **General**

Detailed design shall be preceded by the Pre-design Report and any field investigation needed to acquire field information adequate for detailed design purposes.

6.4.2 **Design Drawings**

Design drawings shall conform to the applicable guidelines, objectives and/or regulations of the reviewing authorities and regulatory agencies.

6.4.3 **Horizontal Controls**

Horizontal control points used for the design survey shall be shown on the drawing complete with co-ordinates.

6.4.4 **Routing**

The outfall terminus location shall preferably extend past any headlands which could create an embayment. Start points, diffusers and all changes in horizontal or vertical alignment should be identified by horizontal co-ordinates.

The outfall shall be designed with a continuous downhill grade to prevent blockages due to solids deposition or air locks.

6.4.5 **Diffuser Design**

- 1) The diffuser for outfalls in remote areas shall be kept as simple as possible. Duck bill valves provide variable orifice diffuser control, opening only as and when needed, thereby maximizing discharge velocity and preventing salt water intrusion at times of low or no discharge. Use of the duck bill valve requires that the outfall pipe be weighted sufficiently through the intertidal zone to stay submerged even when full of air.
- 2) Diffuser ports shall be located perpendicular to the prevailing current if possible. If this is not possible, the diffuser design shall be modified to minimize the overlap of the plumes. This may require angling of the diffuser, fanning of ports, or alternating port angles. The size and spacing of ports must be set by hydraulic analysis.
- 3) Port sizes are to be determined by hydraulic analysis but shall not be less than 50 mm for treated wastewater. Ports may also be equipped with duck bill valves. The sizing of the ports shall consider the hydraulic losses through the duck bill valves, based on the manufacturer's performance data.
- 4) Design of multiple port diffusers shall be optimized by use of initial dilution computer models. Selected configurations are to be checked for hydraulic performance using the methods of Rawn, Bowerman and Brooks. Unit discharge should not vary more than 10% over the length of the diffuser; and only enough ports should be open to guarantee full flow at least daily. The diffuser design shall be able to accommodate the maximum discharge for the outfall, as well as the existing peak flows by staged commissioning of ports.

6.4.6 **Hydraulics**

- 1) Velocities greater than 0.9 m/second in the pipe barrel shall be exceeded on a daily basis. If this cannot be achieved, means of flushing the sediment from the outfall shall be specified on the design drawings or in the design brief, and in the description of Operation and Maintenance tasks.
- 2) Hydraulic analysis shall be conducted to account for the following:
 - i. friction loss;
 - ii. density head;
 - iii. entrance, exit, and form losses at critical flows and tides; and
 - iv. losses through orifice valves.

6.4.7 **Materials**

- 1) For background information on metallic marine environment construction materials refer to Appendix V of these guidelines.

2) Pipe

Piping for outfall lines may be constructed from the following materials:

- a) high density polyethylene;
- b) coated steel (coated and lined)
- d) welded piping is most desirable but joints must be adequately protected;
- e) pipe sections must be bonded together if couplings are used;
- c) ductile iron (coated and lined);
- f) pipe sections must be bonded together;
- d) glass fibre reinforced plastic (with appropriate joint restraint);
- e) concrete (with appropriate joint restraint).

3) Flanges

Flanges are normally fabricated from carbon steel with a corrosion protective coating. (See "Coating and Linings" below.) Suitable non-metallic flanges may also be used (e.g., PVC Vanstone flanges and flanges made from high density molecular plastic).

4) Bolting

Bolts in marine environments that will require future adjustment or removal should be Hastelloy C276, Inconel 625, Avesta 254 or silicone bronze 665. All other metallic bolts shall be for buried pipeline service and shall be fully coated as noted in (6) below.

5) Couplings

Couplings that will not require future adjustment or removal shall be coated with a corrosion barrier layer. For couplings that will require future adjustment or removal, metallic components shall have a high corrosion resistance in marine environments. Metallic components shall be bonded to the pipe if it is metallic.

6) Coatings and Linings

Acceptable coatings and linings are as follows:

- i. coal tar enamels and coal tar epoxies to AWWA Standards;
- ii. extruded polyethylene (yellow jacket) for outside diameter;
- iii. coal tar mastic for couplings;
- iv. concrete mortar linings; and
- v. cold applied petrolatum compounds (e.g. Denso Paste and Tape) for all exposed metal flanges, bolts and couplings.

Note: coatings and linings shall not be used on stainless steel components.

7) Cathodic Protection

- i. impressed current (cathodic protection);
- ii. anodes - silicone-iron or platinized niobium;
- iii. sacrificial anodes of zinc or aluminum.

64.8 Joints

Underwater joints shall be watertight and provide sufficient tensile restraint to withstand hydraulic working pressure, flushing, and deflection due to settlement.

64.9 Depth of Cover

- 1) Outfalls shall be sufficiently buried through the intertidal zone to prevent scour and littoral drift of the bed from exposing the pipe. The length of burial is dependant upon the maximum current from wave action and the nature of the seabed material.
- 2) Where active beaches (build-up & erosion) are encountered, oceanographical and/or geotechnical specialists shall be consulted for trench depth.
- 3) Pipe cover shall be designed to prevent movement from maximum currents.

64.10 Protection

All outfalls must be marked on shore with an appropriate sign indicating the length and depth of the outfall. The minimum size of the sign is 1.0 m² and the colours of the lettering and the background must be of sufficient contrast that the wording is clearly visible. Refer to the BC Municipal Sewage Regulation.

When the pipe is laid directly on the seabed consideration shall be given to protecting the pipe, particularly from the following:

- g) commercial fishing;
- h) recreational or commercial crab trapping;
- i) anchoring by recreational boaters;
- j) logging; and
- k) shipping.

The nature of this protection may include the following:

- l) burial;
- m) placement of rock rip rap over the outfall pipe, which has a suitable surrounding protective cover;
- n) prefabricated concrete capping (e.g. tunnel weights or articulated ballast mats).

6.4.11 **Weighting**

Analysis shall be performed to determine the size and types of weight necessary to ensure stability with an adequate factor of safety in the design current, wave or bedding condition. A minimum buoyancy design for 20% volume of air in the pipe shall be assumed to allow for variations in alignment, grade, currents and gas entrainment.

Polyethylene (PE) pipe is suitable to most outfalls serving First Nations communities. As it is buoyant, even when full of water, it shall be weighted to provide a reasonable factor of safety against movement. Use of conventional concrete pipe to act as a "tunnel" weight has become popular. Care shall be taken in the attachment details to prevent weights from sliding during the installation of the outfall.

Consideration shall also be given to the security of the weighting if an outfall is ever to be raised for lengthening or repair.

Two piece, square, circular or octagonal weights may be used in weighting PE pipe. Bolts shall be corrosion resistant as described in Section 6.4.7(4) and the weight shall be suitably designed for its exposure class (e.g. submersion in marine waters). When 2 piece weights are used, a single layer padding of 6mm high density neoprene is required between the pipe and the weight.

When duck bill valves are used as a terminus structure, the intertidal portion of the outfall shall be considered as being empty when calculating weighting requirements.

6.4.12 **Construction Considerations**

Availability and location of a site suitable to store piping materials and/or prefabricate the outfall (staging area) shall be considered during the design stage and specified on the drawings in relationship to the work area.

A Qualified Professional or his or her representative shall be present during construction of the outfall, or inspect the finished product after construction. If the Qualified Professional is unable to do the site inspection the contract documents shall require the contractor to provide an underwater video of the outfall installation. The pipe shall be marked with length markings at least every 10 metres prior to placement to facilitate inspection and/or location of video observations.

6.5 SURVEYS AND APPROVALS

6.5.1 Surveys

The seabed below the high tide level is controlled by the Provincial Government. The approval process will require legal surveys and application fees.

6.5.2 Approvals

Approvals for an outfall installation shall be obtained by the Qualified Professional from the following agencies:

- o) Provincial Ministry of Environment (MOE);
- p) Integrated Land Management Bureau, Ministry of Agriculture and Lands;
- q) Transport Canada Navigable Waters Protection Division; and
- r) Harbour Commissions or Port Authorities (if applicable).

In addition, the Federal and Provincial Departments of Fisheries shall be advised of proposed installations and their input must be obtained on timing of construction relative to fish migration patterns and measures to mitigate harmful alteration, disruption or destruction (HADD) of fish habitat. A “letter of advice” from Fisheries shall be provided along with the construction stage funding application, and copies of the same must be available on site during construction. This is especially necessary for projects involving underwater blasting, dredging, excavating of intertidal areas and pipe burial.

Registration with the B.C. Ministry of Environment (MOE) is required under the Municipal Sewage Regulation. Standard applications for registration under the Municipal Sewage Regulation are available from the district offices of MOE (see Appendix VI for contact information).

There are a variety of tenures available through the Integrated Management Bureau, Ministry of Agriculture and Lands. These are discussed in detail in Appendix VI.

For outfalls into Federal Harbours (e.g., Victoria, Esquimalt, Vancouver, Nanaimo and Prince Rupert), approvals are required from Transport Canada, Harbour Commissions or Port Corporations.

Transport Canada, Navigable Waters Protection Division has responsibility for all navigable waters. Any structure placed in a body of water considered to be navigable requires authorization or an exemption under the Navigable Waters Protection Act. Most outfalls qualify for exemption, with certain requirements, such

as Marine Traffic Warning signs or burial in the seabed. Application for exemption under the Navigable Waters Protection Act must be made through Transport Canada (see Appendix VI for contact information).

For outfall construction, written approval from the Integrated Land Management Bureau must be provided with the construction stage funding application.

The “pre-construction approval” is based on a proposed legal description of the land to be occupied based on the selected alignment. During the pre-construction survey stage, the Qualified Professional will have obtained three dimensional survey data to describe the bathymetry in the general area of the proposed outfall (bathymetric survey). The bathymetric survey will generally be obtained with a Differential Global Positioning System (DGPS) integrated with a recording depth sounder (bathometer), and correlated to the upland survey. The Qualified Professional will then select the preferred route, based on the bathymetric survey. Accordingly, the general description of the desired route can be defined in relatively close “legal survey” terminology.

A methodology that enables the contractor to place the outfall on the desired alignment must be prescribed. However, tides, currents, or inaccurate placement techniques may result in the outfall being placed in a different position to that identified in the “pre-construction” approval process. In recognition of this possibility occurring, the qualified professional is obligated to submit the formal “post construction” survey of the placement of the outfall position, and the limits of the requested “right-of-way”. This information should be summarized on marine charts (digital imagery as well as paper charts). The Qualified Professional should forward this information to Transport Canada and the Institute of Ocean Science and include it in the project completion documentation.

6.6 POST DISCHARGE MONITORING

6.6.1 General

Newly constructed outfalls shall be inspected immediately after installation and again one year after initial construction, before the contractor maintenance period expires. If the outfall is operating satisfactorily, the next inspection shall be done five years hence or sooner if abnormal operation conditions are observed (e.g. surfacing of effluent plumes or excessive back pressure).

Post discharge monitoring shall be undertaken in accordance with the requirements of the environmental assessment, to monitor for long-term changes in the receiving environment. Costs of post discharge monitoring shall be included in the operation and maintenance cost estimate.

6.6.2 Outfall Performance Assessment

Outfall performance evaluations can involve dye injection and/or coliform sampling programs. The purpose of dye injection is to confirm the continuity of the pipe, and the plume movement. The coliform sampling program establishes the public health impact and risks of the discharge and assesses the background coliform contribution.

Water sample analysis for both fecal and total coliforms can be undertaken to delineate the plume movement, initial and secondary dilution, and background concentrations. Sampling programs are similar to those undertaken during the feasibility and pre-design stages, and samples are collected at representative stations throughout a full tide cycle to assess diurnal variation. Although total coliforms are not necessarily related to wastewater discharges, their high concentration in the wastewater (5 to 10 times the fecal coliform concentration) makes them better suited to plume tracking. Statistical design is essential to coliform surveys and shall be undertaken.

Dye and/or bacteriological studies shall be considered.

Samples shall be collected and analyzed in accordance with the APHA-AWWA-WPCF "Standard Methods" (latest edition). All samples shall be stored in a cooler with ice immediately upon collection to protect the sample from solar radiation and consequential bacterial die-off.

Coliform analyses shall be undertaken within six hours of collection where possible, with a maximum storage time of 24 hours if required. Where samples cannot be analyzed within six hours, an adjustment for storage die-off assessment shall be considered. All analyses shall be made using membrane filter techniques (MFT) unless excessive turbidity requires the analysis by multiple tube fermentation techniques (Most Probable Number - MPN). A coliform assessment of shoreline sources as discussed in the Pre-design monitoring program shall be undertaken to estimate the influence of these sources on observed coliform concentrations at the offshore stations. A routine sampling program of shellfish tissue and sediments for total and fecal coliforms shall also be undertaken as part of the public health assessment.

6.6.3 **Long Term Maintenance Monitoring and Visual Inspections**

Outfall inspection and long term monitoring is required for the purpose of assessing changes in the receiving environment and sediment loading in the vicinity of the outfall terminus, and assessing changes in the hydraulic capacity of the outfall.

Routine visual inspections of the outfall by divers are required. The outfall shall be inspected at least once every five years, with increased inspections for outfalls in higher risk areas.

Flushing of outfalls to remove accumulated solids is not normally required. However, if the hydraulic capacity of the outfall is observed to decrease, this is an indication of solids accumulation and the outfall should be flushed and the source of the excess

solids identified and corrected. If hydraulic constraints persist after flushing, an inspection of the pipeline should be conducted to evaluate if the physical installation has been compromised (e.g., to check if the pipe has been kinked).

6.7 OPERATION AND MAINTENANCE OF OUTFALLS

The scope of operation and maintenance, the contents of the Operation and Maintenance Manual, the Operation and Maintenance Plan and the Emergency Response Plan shall follow the relevant parts of Section 1.9. The Operation and Maintenance Documents shall be drafted during the Pre-design and Design stage and finalized after construction.

APPENDIX I

INAC GUIDANCE DOCUMENTS FOR ENVIRONMENTAL ASSESSMENTS

- 1) A Summary of the Environmental Screening Process for First Nations Capital Projects.
- 2) INAC General Terms of Reference for Environmental Assessments.

**A Summary of the
Environmental Assessment Process
for
First Nations Capital Projects**

**Funding Services
Department of Indian Affairs and Northern Development
British Columbia Region
1138 Melville Street
Vancouver, B.C.**

TABLE OF CONTENTS

Environmental Assessment Screening Mandate	1
Submission Requirements	1
Environmental Assessment Scoping Report Description	2
1. Project Environmental Concerns	2
2. Investigation Identification	2
3. Field Investigation Environmental Impacts	3
Environmental Assessment Study Report Description	3
Environmental Assessment Evaluation	3
1. Environmental Assessment Scoping Report	3
2. Environmental Assessment Study Report	4

Appendices

- A. General Terms of Reference for Completing Environmental Assessments
- B. Environmental Assessment Screening Report
- C. CEAA Exclusion List

A Summary of the Environmental Assessment Screening Process for First Nations Capital Projects

Environmental Assessment Screening Mandate

Projects funded by INAC require an Environmental Assessment (EA) in compliance with the *Canadian Environmental Assessment Act (CEAA) S.C. 1992 c.37 and amendments S.C. 2003 c.9* and any regulations made there under, as amended or replaced from time to time.

Submission Requirements

One of the objectives of CEAA is "to ensure that an environmental assessment of a project is conducted as early as practicable in the planning stages of the project and before irrevocable decisions are made". To meet this objective, the following EA reports are requested at the indicated stages in a project:

- Environmental Assessment Scoping Report - to be completed during the Feasibility Stage and must be included with the Design Stage funding submission.
- Environmental Assessment Study Report - to be completed during the Design Stage and must be included with the Acquisition / Construction Stage funding submission.

The concept of a two-step environmental process is intended to effectively address environmental concerns relating to the development of a project before significant funds and time are expended. Any project submission at the completion of the Feasibility Stage and the Design Stage must include the applicable EA Report.

First Nations communities operating under a Canada First Nation Financial Agreement [CFNFA] are also required complete an EA report for projects. An EA Study Report shall be submitted and a signed screening decision received by the proponent prior to the Acquisition/Construction stage of a project.

Where field investigation activities (e.g. groundwater/geotechnical drilling) are required during the feasibility stage, an environmental evaluation focussed only on field investigation activities which addresses potential environmental concerns and includes appropriate mitigation measures must be completed and submitted with the feasibility study funding application.

EA Reports (Scoping and Study) must be completed by a qualified assessor. Assessor qualifications will vary depending on the magnitude and technical complexity of a proposed project.

The EA Scoping Report shall outline the proposed workplan of the EA Study Report. The workplan should be appropriate for, and will vary based on, the magnitude and technical complexity of the project.

A description of requirements for completing EA reports is detailed in Appendix A: "General Terms of Reference for Completing Environmental Assessments".

Under any funding arrangement where CEAA is triggered, an EA screening decision signed by a Responsible Authority must be received by the project proponents before proceeding to the next stage of a project.

Environmental Assessment Scoping Report Description

The first step in the process will produce an EA Scoping Report which is a deliverable of the Feasibility Stage of the Capital Project Process. This report must be a stand alone document and is intended to:

- describe the project and determine the scope of assessment
- identify the environmental setting
- identify potential environmental impacts
- identify anticipated cumulative effects
- identify potential community concerns and planned consultation
- summarize available site reports and assessments
- identify additional environmental investigations required
- assess environmental impacts of proposed design stage site investigations and identify appropriate mitigation.

The following three objectives are identified for the EA Scoping Report stage:

1. Project Environmental Concerns

Potential environmental impacts which may affect the acceptance of the project are identified. In some cases, the environmental impacts identified at this stage may be considered unacceptable causing the initial project concept to be abandoned or modified. The intent is to identify environmentally unacceptable projects early in the project development stages before significant dollars are spent on subsequent engineering investigations and designs.

Examples of potential environmental impacts which should be identified in the EA Scoping Report are:

- The impact of effluent from a wastewater treatment plant discharged into a marine environment;
- The impact of community development on species at risk or their habitat;
- The impact of subdivision development on the amount of vehicular traffic through a residential area;
- Community concerns generated by the development of a specific location which may have particular archeological or environmental significance.

2. Investigation Identification

The scope of engineering and environmental investigations required to adequately assess potential environmental impacts are determined. These investigations will provide the necessary information to develop mitigation measures to address the environmental impacts. For example, the requirement for a hydro geological study to assess the health impacts of disposal field effluent potentially breaking out of an adjacent embankment would be identified as a requirement for further study during the EA Study Report stage.

3. Field Investigation Environmental Impacts

Environmental impacts resulting from field investigation activities carried out during the design stage of the project are fully investigated. For example, assessment and mitigation for activities such as site surveying and geotechnical work must be documented.

Environmental Assessment Study Report Description

The second step in the EA process will produce an EA Study Report which is a deliverable of the Design Stage of the Capital Project Process. This report must be a stand alone document and include reference to applicable final design drawings and construction specifications to allow for review of the proposed environmental mitigation activities. In addition to the items addressed in the EA Scoping Report, the EA Study Report should:

- list studies or investigations completed
- detail proposed project activities
- describe specific environmental impacts and how they were assessed
- explain mitigative measures incorporated into the design
- evaluate any cumulative effect impacts
- evaluate and mitigate the environmental impact of operation and maintenance tasks and potential malfunctions.
- outline requirements for on-going monitoring
- address the future environmental impacts of decommissioning.
- assess community support for the project

Environmental Assessment Evaluation

To process an EA decision for a project, five copies of the EA Scoping Report or EA Study Report are to be submitted.

The EA document will be processed in accordance with the following analyses:

- "DOES NOT MEET THE REQUIREMENTS" - The submitted document does not provide the necessary information to make an environmental screening decision. Additional issues which are to be addressed before a screening decision can be made will be outlined in writing.
- "MEETS THE REQUIREMENTS" - The submitted document provides all the necessary information to make an environmental screening decision.

If the submitted document "MEETS THE REQUIREMENTS" - one of the following screening decisions will be processed (an example of INAC's screening decision report is provided in Appendix B):

1. Environmental Assessment Scoping Report

- SCREENING DECISION "00 - Environmental assessment underway - no decision yet" indicates initial environment concerns have been identified. Procedures to mitigate the identified concerns will be finalized during the Environmental Assessment Study Report stage.

A memo will be generated if clarification and/or additional comments and considerations are to be incorporated into the Environmental Assessment Study Report. The project may proceed to the next stage of the capital project process.

- SCREENING DECISION "02 - Effects likely significant and cannot be justified - project is not supported" indicates the project as presented should not proceed to the next capital project stage. A written explanation will outline the rationale for this decision.

Modifications to the project may warrant further environmental assessment and a re-evaluation of the original screening decision.

2. Environmental Assessment Study Report

- SCREENING DECISION "01 - Effects not likely significant (considering mitigation measures) and public concern does not warrant further assessment - project supported" indicates significant environmental impacts have been addressed through mitigative measures and the project may proceed to the acquisition / construction stage of the capital project process.

- SCREENING DECISION "02 - Effects likely significant and cannot be justified - project is not supported" indicates the project as presented should not proceed to the acquisition / construction stage. A written explanation will outline the rationale for the decision.

Modifications to the project may warrant further environmental assessment and a re-evaluation of the original screening decision.

Comments or clarification regarding the EA process can be discussed with your Capital Specialist or District Engineer.

Appendix 10B

General Terms of Reference for Environmental Assessment

INAC GENERAL TERMS OF REFERENCE FOR ENVIRONMENTAL ASSESSMENTS

1. Background & Definitions

The Canadian Environmental Assessment Act (CEAA) was developed to minimize or avoid adverse environmental effects before they occur and to incorporate environmental factors into project decision making early in the project planning process.

All INAC projects require the completion of an Environmental Assessment (EA) unless specifically set out in the Exclusion List Regulations of CEAA. This terms of reference addresses general considerations for the completion of an EA. Specific projects (e.g. sand and gravel permits, leases, wastewater treatment systems, logging permits, and complex projects) may require additional investigations beyond those outlined here. The appropriate Lands and Trust Services (LTS) Environmental Specialist, LTS Natural Resources Officer, or District Engineer should be consulted early in the project process to ensure that the planned EA meets all specific project requirements.

The following are key terms required to properly interpret this Terms of Reference:

Scoping	An integral part of the EA process that determines the extent of the EA investigation and the appropriate level of detail and complexity.
Valued Ecosystem Component (VEC)	Ecosystem components that are considered important or valuable, which must be considered during the EA process.
Environmental Effect	Any change a project may cause in the physical environment including any changes to listed wildlife species and their critical habitat or residences, as defined by SARA. Effects of changes to health and socio-economic conditions, physical and cultural heritage, structures, sites, or things of historical archaeological, paleontological, or architectural significance, and the current use of lands and resources for traditional purposes by aboriginal persons require consideration.
Species at Risk Act (SARA)	An EA must ensure that the potential for environmental effects on a species at risk and its habitat, as defined by SARA, have been adequately assessed.

Cumulative Effect	Changes to the environment that are caused by an action being considered in a project in combination with other past, present, and future human actions.
Mitigation	The elimination, reduction, or control of the adverse environmental effects of a project. Mitigation may include compensatory measures for damage to the environment.
Accessory Activities	Accessory activities include physical works that must be completed to allow the principal project to proceed (e.g. access roads, drilling, test pits, surveys, etc.)

Project proponents who are unfamiliar with CEAA should review guidance information available at www.ceaa-acee.gc.ca. Information on the consideration of SARA in an EA is available in "Environmental Assessment Best Practice Guide for Wildlife at Risk in Canada, 1st Edition, Feb. 27, 2004". This document can be found at www.ec.gc.ca/guide_e.html.

2. Environmental Assessment Scoping

Scoping is a critical first step in the EA. Scoping will determine the limits of the EA and will focus future analysis on the relevant issues and concerns. The key elements in the scoping process which must be considered in all EAs are:

- Determine project undertakings and activities that must be assessed as part of the EA.
- Determine what factors and issues need to be considered in the EA.
- Determine who will be involved in the EA, their interests and concerns.

2.1 Environmental Assessment Scoping Report

Although scoping is part of the EA process for all projects, an EA scoping report is only required for INAC funding services capital projects and where specifically directed by your INAC environmental or natural resources specialist for INAC Lands and Trust Services projects.

An EA scoping report is to be a stand alone document which includes the project description, environmental setting, significant environmental issues, valued ecosystem components (VECs), and completed and planned EA investigations. This report is completed during the feasibility stage of a capital project and when directed by LTS and will be used in the assessment of project viability. The following are to be addressed in the EA scoping report.

- 2.1.1 Introduction** Provide a summary description of the project including construction, operation, decommissioning, and other activities expected during the life of the project. Project proponent contact information including organization, name, mailing address,

telephone number, and email address (if available) are required. Provide a list of information sources used.

2.1.2 Maps/Plans

Provide plans showing the geographical location of the project with latitude and longitude, the proposed location(s) of the project within the context of the Reserve and an overall preliminary plan for the project. Include environmentally significant features (e.g. water bodies, forests, significant elevation changes, species ranges, known habitats, etc.) Where appropriate and readily available, inclusion of First Nation nomenclature for place names, flora, fauna, etc. should be considered. Copies of topographic maps and aerial photos/mosaics should be provided where available.

2.1.3 Environmental Setting

Provide a summary description of the existing environment in the project area including landscape, waterbodies, archeology, natural resources, and environmental uses (e.g. wildlife habitat, natural resource harvesting, residential properties, etc.). Indicate the areas potentially affected by the project. Outline known environmentally significant historical uses and develop a list of VECs for the project. Where multiple sites are being considered during the feasibility stage, environmental restrictions and impacts at each site must be considered and incorporated into the site selection process.

Socio-economic conditions should be described if potentially impacted by environmental changes caused by the proposed project.

2.1.4 Environmental Effects

Indicate known and suspected environmental effects of the project on listed VECs.

Identify any cumulative effects that are anticipated on the basis of initially available information. Include effects likely to result from the project in combination with other pre-existing developments and/or in combination with developments that will be carried out as a direct result of this project.

2.1.5 Studies / Investigation

Describe the scope of work for the planned EA. Document site assessments completed to date. Identify further investigations which are required to address situations where environmental effects are unknown or to determine appropriate mitigation activities.

A determination must be made as to the likely presence of wildlife, birds, aquatic life, flora and/or habitat at risk in the project area. This determination must be made using relevant data base lists, range maps, local knowledge (where available), and other existing information on species known to occur in the project area. Where the range of a species at risk overlaps with the proposed project area, existing information sources must be checked and documented to determine whether actual or potential habitat or residences for these species are present.

Example information sources include: the Conservation Data Centre (CDC) for rare element occurrence records, Committee on the Status of Endangered Wildlife in Canada (COSEWIC), the Species at Risk Public Registry for recovery strategies, recovery teams, action plans and management strategies, and the Ministry of Sustainable Resource Management's Species and Ecosystem Explorer.

2.1.6 Public Consultation

Document consultation with other government departments and agencies. Provide contact information. Outline any additional consultation planned with the community, public, or other government departments and agencies as part of the EA.

2.1.7 Accessory Activities

Accessory activities planned during the design stage must be assessed (e.g. geotechnical, surveys, etc.). Identify activities causing significant environmental impacts on VECs and outline mitigation measures that will be implemented. Note: Accessory activities planned during feasibility and associated mitigation measures must be summarized in the feasibility stage proposal.

3 Environmental Assessment Study Report

An EA study report describes in detail, the environmental effects from construction, operation, modification, decommissioning, abandonment, malfunction, and cumulative effects on VECs. Proposed mitigative measures, including follow-up activities and their expected outcomes once implemented, are clearly identified. For capital projects the EA Study Report will usually be completed during the design stage. For LTS projects the EA Study Report should be completed early in the project process since EA information is used in other aspects of land designation, leasing etc. In all cases the EA must be submitted as a stand alone document. Projects which trigger CEAA cannot proceed to implementation without a screening decision by INAC based on the EA Study Report.

3.1 Introduction

Provide a summary description of the project including construction, operation, decommissioning, and other activities

expected during the life of the project. Project proponent contact information including organization, name, mailing address, telephone number, and email address (if available) are required.

3.2 Studies/Investigations Summarize the results and recommendations of studies carried out as part of the EA (e.g. geotechnical studies, water quality investigations, SARA wildlife & habitat surveys, archaeological investigations, survey results, fisheries studies, etc).

**3.3 Maps/Plans/
Nomenclature**

Provide scaled plans showing the geographical location of the project with latitude and longitude, the location of the project within the context of the Reserve, and an overall site plan for the project. Include environmentally significant features (e.g. water bodies, forests, significant elevation changes, species ranges, known habitats, etc). Where appropriate and readily available, inclusion of First Nation nomenclature for place names, flora, fauna, etc. should be considered. Copies of topographic maps and aerial photos/mosaics should be provided where available.

3.4 Environmental Setting Provide a detailed description of the existing environment in the project area including landscape, waterbodies, archeology, natural resources, and environmental uses (e.g. wildlife habitat, natural resource harvesting, residential properties, etc). Indicate the areas affected by the project. Outline known environmentally significant historical uses in the area of the project. Develop and/or update the list of VECs in the project area.

Socio-economic conditions should be described if potentially impacted by environmental changes caused by the proposed project.

Where an EA scoping report has not been completed (e.g. projects completed for LTS) the likelihood of wildlife, birds, aquatic life, flora and/or habitat at risk in the study area must be determined using relevant data base lists, range maps, local knowledge (where available), and other existing information on species known to occur in the project area.

Where species at risk are identified whose range overlaps with the proposed project area, existing information sources must be checked to determine whether actual or potential habitat or residences for these species are present in the project area.

Example information sources include: the Conservation Data

Centre (CDC) for rare element occurrence records, Committee on the Status of Endangered Wildlife in Canada (COSEWIC), the Species at Risk Public Registry for recovery strategies, action plans, and management strategies, and the Ministry of Sustainable Resource Management's Species and Ecosystem Explorer.

For all projects where potential interactions with species at risk have been identified, field surveys, consistent with published recovery plan strategies, will be required to determine whether individuals of species at risk, critical habitat, recovery habitat, or residences occur in the project study area.

3.5 Project Activities

Provide a detailed description of all potential project activities throughout the project life cycle including construction, operation, modification, decommissioning, abandonment, malfunction, and potential accidents.

Where environmentally responsible solutions have been incorporated into project development (e.g. energy efficient buildings, water conservation, alternative energy) describe expected environmental benefits. For more information see the Green Building Checklist available from LTS.

3.6 Environmental Effects

Verify significant environmental effects on VECs caused by project activities and quantify where possible. Examples include but are not limited to: destruction of vegetation and habitat by construction equipment, damage to sites with cultural or archaeological significance, siltation of surface waters, sedimentation of lake bottoms and river beds, soil contamination through improper storage and disposal of waste products, emissions causing air quality and climate change impacts, release of chemicals to groundwater through accident or system failure, etc.

Verify any cumulative effects that are anticipated. Include effects likely to result from the project in combination with other pre-existing developments and/or in combination with developments that will be carried out as a direct result of this project.

3.7 Mitigation

Detail how environmental effects will be mitigated and show how the mitigation measures have been included in the design of the project. Applicable portions of the design and/or operation and maintenance information should be referenced in the EA report document (refer to specific design drawings where applicable) to confirm that mitigation measures have been incorporated.

	<p>Where a project causes interactions with species at risk, specific mitigation measures must be identified. Mitigation strategies for species at risk are hierarchical with avoidance being preferred (e.g. timing, design/location change), followed by minimization through project modification or implementation under special conditions, and lastly, compensatory mitigation (e.g. replacement of lost habitat).</p>
3.8 Permits & Approvals	<p>Provide information on the status of required environmental permits and approvals necessary to undertake the project (e.g. rights of way, fisheries authorization, navigable waters, sand and gravel, and timber permits).</p>
3.9 Supporting Documentation	<p>When available include correspondence and/or approvals from other government departments (e.g. Health Canada, Fisheries and Oceans, Environment Canada, B.C. Ministry of Water Land and Air Protection, BC Ministry of Sustainable Resource Management: Archaeology and Registry Services Branch etc.)</p>
3.10 Public Participation & Consultation	<p>Document strategies used to assess project input from the First Nation community and/or public. Identify concerns that were raised and how they were addressed and/or mitigated.</p>
3.11 Closure	<p>Provide a narrative summary of the environmental effects associated with the proposed project. Make a determination of their significance (not likely significant or significant). For significant impacts, summarize proposed mitigation strategies and how they will reduce environmental effects. Quantify wherever possible. Where follow-up is recommended, discuss planned follow-up activities. Include a table which shows VECs, project activities, environmental effects, mitigation measures, and reference to supporting documents. For VECs where impacts are found to be not likely significant ensure that justification is provided. Provide a recommendation regarding project viability based on environmental considerations.</p>

APPENDIX II
CLASSES OF COST ESTIMATES

CLASSES OF COST ESTIMATES

(A) **Class A Estimate**

This is a detailed estimate based on quantity take-offs from final drawings and specifications. It is used to evaluate tenders or as a basis of cost control during day-labour construction.

(B) **Class B Estimate**

This estimate is prepared after site investigations and studies have been completed and the major systems defined. It is based on a project brief and preliminary design. It is used for obtaining approvals, budgetary control and design cost control.

(C) **Class C Estimate**

This estimate, which is prepared with limited site information, is based on probable conditions affecting the project. It represents the summation of all identifiable project component costs. It is used for program planning; to establish a more specific definition of client needs and to obtain approval in principle.

(D) **Class D Estimate**

This is a preliminary estimate which, due to little or no site information, indicates the approximate magnitude of cost of the proposed project, based on the client's broad requirements. This overall cost estimate may be derived from lump sum or unit costs as identified in the construction cost manual for a similar project. It may be used to obtain approval in principle and for discussion purposes.

APPENDIX III

WASTEWATER FACILITY CLASSIFICATION AND OPERATOR CERTIFICATION

WASTEWATER FACILITY CLASSIFICATION AND OPERATOR CERTIFICATION

The following information is summarized from material published by the B.C. Environmental Operators Certification Program (EOCP). Additional information is available from the EOCP at:

- s) Website www.eocp.org
- t) Telephone: 1-888-552-EOCP or 604-874-4784
- u) Fax: 604-874-4794

FACILITY CLASSIFICATION

Classification of a facility provides an indication of the degree of knowledge and training that will be required of an operator of that facility. Wastewater collection systems are classified based on flow, and complexity. Municipal and industrial wastewater treatment facilities are classified based on flow, complexity of operation, variability of influent and effluent requirements, and analytical laboratory controls carried out at the facilities. Facilities are classified from Small Systems to Class I through IV with Class IV systems being the largest or most complex.

The B.C. Ministry of Environment mandated a system of classification of municipal wastewater treatment facilities effective August 1, 1993. The program is administered by the Environmental Operators Certification Program. Effective July 1999, the B.C. Municipal Sewage Regulation requires facility classification. Facility classification forms are available at the program office.

Small Wastewater Systems

Typically, small wastewater collection or wastewater treatment facilities have operators who are not required for full-time, daily attention. The systems are relatively simple, serve only a small population and/or are operating for only a portion of any given year. Most operators of such facilities are not able to meet the minimum requirements for Level I-IV certification; in particular, achieving the operating experience (2000 hours) required to write a Level I exam in a reasonable period of time. Small System classification and operator certification is intended to insure the qualification of operators who work on systems that may not normally fit within the regular certification process. There are two types of facility classification and operator certification for Small Wastewater Systems:

- v) Small Wastewater System – lagoon (includes collection and treatment)
- w) Small Wastewater System – mechanical (includes collection and treatment)

The criteria for Small Systems classification and operator certification have been developed in conjunction with other jurisdictions in Canada and the U.S. and follow the guidelines as identified with the Association of Boards of Certification.

1. the facility/system serves a maximum population of 500 people or per capita equivalents;
2. the treatment component of the facility/system is classified as a Class I or Class II facility;
3. the operator must have a grade 10 education and have completed appropriate training for which a minimum of 1.5 continuing education units have been awarded. If not able to meet the education requirement, experience may be exchanged for the education on a year for year basis.

Each of the Small System exams is comprised of 50 multiple-choice questions. An operator holding a Small System certificate will be recognized as a certified operator only at facilities considered Small Systems. A Small System certificate does not preclude an operator from writing exams to obtain a full Level I-III certificate once the required experience and/or education is acquired. An operator holding a Level I or higher certificate is recognized as a certified operator in all facilities including Small Systems up to the level of his/her certificate.

Facility classification provides both the facility operator and the owner with an indication of the level of certificate the facility operators should hold. Under a system of mandatory facility classification it is the owner's responsibility to ensure that operators have access to the training activities needed to upgrade their certificates and the operator's responsibility to ensure that he/she obtains the necessary level of certification. In order for an operator to become certified at a Level III or IV it is first necessary that the facility in which he/she is employed be classified.

Operator Certification

Wastewater operators will generally be certified as Small Wastewater System, Level I, Level II, Level III or Level IV operators with IV being the highest or most advanced, paralleling the facility classification. In addition, wastewater operators may be certified as an Operator-in-Training.

The requirements for each level of certification are in accordance with the following outline. The Board will consider a variation in the requirements on a case-by-case basis upon presentation of a request to do so and sufficient explanation of special circumstances.

Small Wastewater System Operator

- x) Minimum Grade 10 education. If the operator does not have a grade 10 education, experience may be exchanged for education on a year for year basis, and
- y) Minimum 1.5 continuing education units (CEU's), and
- z) Minimum of at least six (6) calendar months (minimum 50 hours) of hands-on experience operating the facility/system or one equivalent to it or higher.

Operator-in-Training

- aa) High school diploma, GED, or equivalent, and
- bb) Three (3) months operating experience in a Class I or higher facility or completion of an approved basic operator-training course.

Operator, Level I

- cc) High School diploma, GED, or equivalent, and
- dd) One (1) year operating experience at a Class I or higher system/facility.

Operator, Level II

- ee) High School diploma, GED, or equivalent, and
- ff) Three (3) years operating experience at a Class I or higher system/facility, and
- gg) A Level I certificate.

Operator, Level III

- hh) High School diploma, GED or equivalent, and
- ii) Nine hundred (900) instructional hours, or ninety (90) CEU's, or ninety (90) quarter credits, or sixty (60) semester credits of post high school training/education in the water or wastewater field, environmental engineering, or related studies, and
- jj) Four (4) years operating experience at a Class II or higher system/facility, and
- kk) For Wastewater Treatment Operators, two (2) years of direct responsibility charge (DRC) operation at a Class II or higher facility, and
- ll) A Level II certificate.

Operator, Level IV

- mm) High School diploma, GED or equivalent, and
- nn) Eighteen hundred (1800) instructional hours, or one hundred eighty (180) CEU's, or one hundred eighty (180) quarter credits, or one hundred twenty (120) semester credits of post high school training/education in the wastewater field, engineering or related studies, and
- oo) For Wastewater Treatment Operators, two (2) years of direct responsible charge (DRC) operation at a Class III or higher facility, and

pp) A Level III certificate.

Where applicable, training/education may be substituted for operating and direct responsible charge (DRC) experience.

Wastewater Collection Operator

A wastewater collection operator performs any combination of tasks pertinent to installation and control of the operation of a water distribution or wastewater collection system including but not limited to:

- qq) excavation and backfilling of material prior to installation or for the repair of any of the described systems;
- rr) installation of pipe and related appurtenances;
- ss) control of flow of wastewater;
- tt) monitor gauges, meters and control panels and observe variations in operating conditions;
- uu) operate valves and gates either manually or by remote control;
- vv) start and stop pumps, engines and generators to control and adjust flow;
- ww) maintain shift logs and record meter and gauge readings;
- xx) collect samples and perform routine field analyses;
- yy) operate power generating equipment;
- zz) make operating decisions in the absence of supervisory personnel;
- aaa) perform duties of shift supervisor in his/her absence; and other related tasks.

The term “operator” shall not normally apply to those individuals who do not have direct “hands-on” responsibilities in the facilities. It is not intended that this title include city, regional district, or industry managers, directors of public works, engineers, technical superintendents, or equivalent, whose duties do not include the actual operation or direct on-site supervision of systems and operators. It shall not apply to welders, equipment operators, carpenters, truck drivers, and others whose work is limited to a single activity, the performance of which does not include direct responsibility for safeguarding public health or the environment in the practice of disciplines described in the guide.

APPENDIX IV
INITIAL DILUTION MODELS

INITIAL DILUTION MODELLING INTRODUCTION

The behaviour of plumes generated when wastewater is discharged at depth, into waters of greater density, can be predicted using numerical models developed by the United States Environmental Protection Agency's Center for Exposure Assessment Modeling (CEAM). CEAM was established in 1987 to provide proven predictive exposure assessment techniques for aquatic, terrestrial, and multimedia pathways for organic chemicals and metals. Models provided by the CEAM include: groundwater; surface water; food-chain; and multimedia models. These models are periodically upgraded by the CEAM to reflect technological and modeling advances and are freely available from the CEAM website.

Currently, there are two current Windows-based mixing zone modeling applications available as recommended by CEAM. The first of these is CORMIX-GI v4.3G, which was designed to replace the pre-existing DOS-based CORMIX v3. Although this application is robust and provides good visualization of plume problems, it is no longer supported by the CEAM. It is now being privately distributed through CORMIX and is quite cost-prohibitive for small projects.

Further information regarding CORMIX products can be found at the following Internet address:

<http://www.cormix.info/index.php>

The second application is Visual Plumes v1.0 (VP), which was designed to replace the DOS-based PLUMES program. Similar to the earlier model, VP supports initial dilution models that simulate single and merging submerged plumes in arbitrarily stratified flow and buoyant surface discharges. Additional new features include graphics, time-series input files, user specified units, and a multi-stressor pathogen decay model that predicts coliform mortality based on temperature, salinity, solar insolation, and water column light absorption.

Detailed information regarding CEAM surface water models, including application downloads and support material, can be found at the following Internet address:

<http://www.epa.gov/ceampubl/swater/index.htm>

VP was designed to promote the idea of future modeling consistency by recommending particular models in selected flow categories. This approach was taken in order to encourage the continued improvement of plume model. The four main models that were incorporated into this application, and recognized by the CEAM, were:

1. DKHW model (based on the pre-existing UDKHDEN model)
2. PDSW model
3. UM3 model (based on the pre-existing UM model)
4. NRFIELD model (based on the pre-existing RSB model)

There is also a fifth three-dimensional, single-port vector experimental model included in this application however this has yet to be officially recognized by CEAM.

DETAILED MODEL DESCRIPTION

All of the models have a common interface for the inputs regarding the diffuser and ambient conditions. These include, but are not limited to, the port diameter, the port elevation, the vertical angle, the horizontal angle, effluent and ambient conditions etc. Each of these is described in detail in the application overview. A brief description of each model and its application is outlined below and finally summarized in Table 1. It should also be noted that these models may be run consecutively, and compared graphically, to help verify their performance.

1. DKHW MODEL

The DKHW model is based on UDKHG and UDKHDEN and is a three-dimensional plume model that applies to both single and multi-port submerged discharges. This model is a Fortran-based executable that is called by VP on demand. This programming method, combined with a more detailed near-field theory than other models, creates a longer execution time.

DKHW uses the Eulerian integral method to solve the equations of motion for plume trajectory, size, concentration and temperature. Using this approach, distance becomes the independent variable, as compared to the Lagrangian formulation in which time is the independent variable.

APPLICATION

DKHW provides detailed calculations for both the Zone of Flow Establishment (ZFE) and in the fully developed zone, and also considers gradual merging of neighbouring plumes. This allows the model to examine near-field conditions in great detail. This is of particular interest for any modeling condition where the receiving environment is sensitive to minor fluctuations from the outfall (e.g. response of salmonids to temperature fluctuations).

DKHW is presently limited to positively buoyant plumes.

2. PDSW MODEL

PDSW is the VP name for the PDSWIN executable model that is based on the previous version of the PDS surface discharge program. This model is also a three-dimensional plume model, however it does not apply to port diffusers. Instead it applies to discharge tributary channels. Similar to DKHW, PDSW is a Fortran-based executable that is called by VP on demand and also suffers from a similar delay in execution time.

PDSW provides simulations for temperature and dilution over a wide range of discharge conditions. It is an Eulerian integral flux model for the surface discharge of buoyant water into a moving ambient body of water that includes the effects of surface heat transfer. It is assumed that the plume will remain on the surface with the buoyancy of the plume causing it to rise and spread in all directions. The momentum of the initial

discharge causes the plume to penetrate the ambient environment at the same time that the current bends the plume in the direction of the flow.

APPLICATION

The modeling environments that this model was designed for are plumes that discharge to water bodies from tributary channels, such as cooling tower discharge canals. Because it is the only model that takes surface heat transfer into account it is applicable to situations where temperature fluctuations in the receiving environment are being examined. One of the key features of this model is that it calculates plume areas within selected isotherms.

3. UM3 MODEL

UM3 is the acronym for the three-dimensional Update Merge (UM) model for simulating single and multi-port submerged discharges. This model is applicable to the majority of modeling cases for small-scale installations. This is not only because it is relatively simple to use but that it also is programmed in Pascal, the programming language of Visual Plumes, and so has a quicker execution speed. UM3 is a Lagrangian model that features the projected-area-entrainment (PAE) hypothesis. This hypothesis quantifies forced entrainment, the rate at which mass is incorporated into the plume in the presence of current. The base assumption here is that the conditions are at steady state. This is not to say that the ambient and discharge conditions are invariant. Simply, that they are only can change as long as they do so over time scales which are long compared to the time in which a discharged element reaches the end of the initial dilution phase. This generally occurs at the maximum rise.

APPLICATION

UM3 is the most robust of the models to be used and provides the quickest solutions to single and multi-port diffuser problems. The disadvantages are that steady state is assumed and several generalizations are made in the theory. The results of this model should then be checked against the output results of other models.

As UM3 is coded in Pascal, the native language of VP, it is fully integrated with VP's background build-up capability. This means that in certain time series applications, that the build-up of background concentration can be calculated.

4. NRFIELD MODEL

This model is the successor to the PLUMES RSB model. NRFIELD is an empirical model for multiport diffusers based on experimental studies on multiport diffusers in stratified currents. This model is based on experiments using T-risers, each having two ports. An important assumption that is inherent in this model is that the diffuser may be represented by a line source. This assumption may have important implications on small mixing zones in which the plumes may not have merged.

APPLICATION

Since this model was developed empirically on multiport diffusers, its limited by the fact that the user needs to specify four diffusers at a minimum. If that is not a problem, NRFIELD is applicable to most mid-size to large-scale outfall scenarios.

**TABLE 1
SUMMARY OF MODEL APPLICATIONS**

MODEL	Applications	Limitations
DKHW	<p>bbb) Examines near-field conditions in detail.</p> <p>ccc) Applies to single and multi-port diffusers.</p> <p>ddd) Good for small scale through large scale installations.</p>	<p>eee) Limited to positively buoyant plumes.</p> <p>fff) Programmed in Fortran and so has a slower execution time.</p>
PDSW	<p>ggg) Provides simulations for temperature and dilutions over a wide range of conditions.</p> <p>hhh) Is only model to look at plumes generated by tributary channels.</p>	<p>iii) Not for diffuser plume problems.</p> <p>jjj) Programmed in Fortran and so has a slower execution time.</p>
UM3	<p>kkk) Simplest and most robust models for single and multi-port diffuser problems.</p> <p>lll) Good for small scale through large scale installations.</p>	<p>mmm) Steady state is assumed and several other generalizations are made in the model theory. This can impose artificial boundaries.</p>

NRFIELD	nnn) Plume model for multiport diffusers only. ooo) Better for large-scale installations with number of discharge ports greater than 4.	ppp) Empirically based and so has limitations for certain environments.
---------	--	---

VISUAL PLUMES TIME-SERIES APPLICATION

For any of the models chosen, VP has the ability to link-in time series files. This capability provides a way to simulate outfall performance over a long period of time and, thereby, over many environmental scenarios. Most effluent and ambient variables change with time over different time intervals. For example, a 24-hour diurnal flow-file can be combined with current-meter data. This is the essence of the pollutant-buildup capability of VP. Although this takes longer to program, it is a useful function for certain modeling scenarios.

APPENDIX V
METALS AND ALLOYS FOR MARINE SERVICE

METALS AND ALLOYS FOR MARINE SERVICE

General

- A general ranking of metals and alloys for marine service in order of decreasing corrosion resistance is shown in Table 1.
- Metals exposed to stagnant or low flow seawater conditions allows marine fouling to accumulate and induce underdeposit corrosion (pitting and crevice) on most stainless steels and nickel copper alloys such as Monel.
- Coatings should not be applied to stainless steel components since this will cause severe corrosion of the stainless steel components.
- To prevent galvanic corrosion mixed metal systems should be avoided if possible.
 - It is desirable that only one type of metal or alloy be used if possible but if more than one type of metal or alloy is used the key components should be more corrosion resistant.
 - Heavier or thicker cross-sections should be used to allow for the increased corrosion on less noble metals.
- Cathodic protection systems should be designed by a Qualified Professional engineer with corrosion experience.
- Coatings and linings should be selected by a qualified Corrosion Specialist.
- Coatings and linings should be inspected by a NACE Certified Inspector.

TABLE 1

General ranking of metals and alloys for marine service in order of decreasing corrosion resistance.

MATERIAL	COMMENTS
Titanium	Fouls but does not suffer underdeposit corrosion.
Ni-Cr-Mo alloys (eg. Hastelloy C276 ,Inconel 625 and Avesta 254)	Fouls but shows no corrosion or only minor pitting.
High alloy stainless steels (6% Mo)	Fouls. May show some slight underdeposit attack.
90:10 copper:nickel (high iron)	Normally does not foul. May show very shallow pitting.
High alloy stainless steel (4.5% Mo)	Less corrosion resistant than 6% molybdenum stainless steels. May develop crevice corrosion under fouling deposits.
Silicon bronze 665	May show fairly high general corrosion rates unless appropriate cathodic protection is used and use of mixed metals is avoided.
Monel	May show relatively severe underdeposit corrosion.
Type 316 Stainless Steel	Severe pitting and crevice corrosion under fouling deposits.
Type 304 Stainless Steel	Very severe pitting and crevice corrosion under fouling deposits.
Cast Iron or ductile iron	General corrosion less than carbon steel.
Carbon Steel	Pitting and heavy general corrosion.

APPENDIX VI

**STANDARDS AND GOVERNMENT AGENCIES TO BE CONTACTED
PRIOR TO DESIGN OF WASTEWATER FACILITIES**

STANDARDS AND AGENCIES TO BE CONTACTED

It is the responsibility of the Applicant to ensure that all of the relevant Provincial, Federal and Local Government agencies are contacted to obtain the necessary approvals and permits and to determine current regulatory requirements prior to construction of the facilities. In most cases, contact should be initiated early in the project to ensure that all of the relevant information and requirements are identified before design of the facilities commences. A partial list of relevant agencies is provided below for information only.

1. Standards for Treatment and Surface Discharge of Wastewater:

- a. INAC Design Guidelines for Wastewater Systems British Columbia Region.
www.inac.gc.ca/extranet
- b. Issues related to the quality of discharges to surface waters, for use of reclaimed water, and for process reliability, reference B.C. Ministry of Environment, Municipal Sewage Regulation and associated guidance documents at:
www.env.gov.bc.ca/epd/epdpa/mpp/msrhome.html
- c. Issues related to the quality of discharges to surface waters, reference Canadian Council of Ministers of the Environment Canada-wide Strategy for the Management of Municipal Wastewater Effluent at
www.ccme.ca/ourwork/water.html
- d. First Nations Wastewater Emergency Response Plan Guide:
Appendix VII or www.inac.gc.ca/extranet

2. Standards for Ground Disposal of Wastewater:

- a. For treatment and discharge of effluent to ground disposal systems on Federal Land from collective systems (five or more house connections or flows equal to or exceeding 9,100 litres/day from non-residential facilities):

INAC Design Guidelines for Wastewater Systems British Columbia Region at:
www.inac.gc.ca/extranet

- b. For treatment and discharge of effluent to ground disposal systems on non-Federal Land from flows of equal to or more than 22.7 m³/day:

B.C. Ministry of Environment, Municipal Sewage Regulation and associated guidance documents at:

www.env.gov.bc.ca/epd/epdpa/mpp/msrhome.html

- c. For treatment and discharge of effluent to ground disposal systems on Federal Land from individual systems (flows of less than 9,100 litres/day):

B.C. Ministry of Health Sewerage System Regulation and associated guidance documents, at

www.health.gov.bc.ca/protect/lup_regulation.html

3. Standards for Treatment of Waste Solids and Septage and for Beneficial Use of Treated Solids (Biosolids):

- a. For biosolids treatment and beneficial use:

B.C. Ministry of Environment, Organic Matter Recycling Regulation at
www.env.gov.bc.ca/epd/epdpa/mpp/omrreg.html

- b. For obtaining a Permit to dispose of or beneficially use waste solids or septage not covered by the Organic Matter Recycling Regulation, contact the B.C. Ministry of Environment at:

www.env.gov.bc.ca

4. Construction of Facilities:

1. Issues related to construction of works in and about fish-bearing waters and related habitat, or waters discharging to fish-bearing waters or habitat, contact Fisheries and Oceans Canada at:
www.helo.pac.dfo-mpo.gc.ca/decisionssupport/os/operational_statements_e.html
2. Issues related to construction of works in and about fish-bearing waters and related habitat, or waters discharging to fish-bearing waters or habitat, contact Fisheries and Oceans Canada and B.C. Ministry of Environment at:
www.env.gov.bc.ca/wsd/water_rights/license_application/section9/index.html

5. Outfall Approval Process:

1. Issues related to permission to occupy affected lands for tidal and non-tidal areas, contact Integrated Land Management Bureau, Ministry of Agriculture and Lands (see next page).

Integrated Land Management Bureau Regional Offices Contact:

Cranbrook ILMB Office
1902 Theatre Rd.
Cranbrook, BC
V1C 6H3
Tel: 250-426-1766
Fax: 250-426-1767

Prince George ILMB Office
Suite 200, 1488 4th Ave.
Prince George, BC
V2L 4Y2
Tel: 250-565-6779
Fax: 250-565-6941

Fort St. John ILMB Office
Room 370 10003 110th Ave
Fort St. John, BC
V1J 6M7
Tel: 250-787-3415
Fax: 250-787-3219

Smithers ILMB Office
PO Box 5000
3rd Floor 3726 Alfred Ave.
Smithers, BC
V0J 2N0
Tel: 250-847-7334
Fax: 250-847-7556

Front Counter BC Kamloops
2nd Floor 301 Victoria Street
Kamloops, BC
V2C 2A3
Tel: 250-372-2127
Fax: 250-377-2150

Surrey ILMB Office
Suite 200 – 10428 153rd Street
Surrey, BC
V3R 1E1
Tel: 604-586-4400
Fax: 604-586-4434

Kamloops ILMB Office
3rd Floor 145 3rd Ave.
Kamloops, BC
V2C 3M1
Tel: 250-377-7000
Fax: 250-377-7036

Whistler–Squamish ILMB Office
42000 Loggers Lane
Squamish, BC
V0N 3G0
Tel: 604-898-2128
Fax: 604-898-2191

Nanaimo ILMB Office
501-345 Wallace Street
Nanaimo, BC
V9R 5B6
Tel: 250-741-5650
Fax: 250-741-5686

Williams Lake ILMB Office
201-172 North Second Avenue
Williams Lake, BC
V2G 1Z6
Tel: 250-398-4574
Fax: 250-398-4836

Penticton ILMB Office
102 Industrial Place
Penticton, BC
V2A 7C8
Tel: 250-490-8200
Fax: 250-490-2231

The Transport Canada, Navigable Waters Protection Division is responsible for the area below high water mark in the Victoria and Esquimalt harbours, the Integrated Land Management Bureau, Ministry of Agriculture and Lands is responsible for the area above high water mark. Thus, application would have to be made to both authorities for an outfall in these areas.

Vancouver

Vancouver Port Authority
100 The Pointe
999 Canada Place
Vancouver, B.C., V6C 3T4

Attention: Mr. Juergen Baumann
Tel: 604-665-9081

The Vancouver Port Authority is responsible for all Vancouver Harbour, North Vancouver, West Vancouver, I.R. #2, #3 and Squamish Indian Band lands. When they receive a letter of application, they respond accordingly informing the applicant of all agencies from which clearance is required. (Fisheries, Environment, Waste Management, etc.).

7. Navigable Waters for issues related to outfalls into

The Navigable Waters Protection Act, R.S., c. Chapters N-19, is a federal statute designed to protect the public right of navigable waters by prohibiting the building or placement of any “work” in, upon, over, under, through or across a Navigable Water, without approval of the Minister of Transport. The Act is administered by the Navigable Waters Protection Division of Transport Canada.

Outfalls into Navigable Waters are subject to the jurisdiction of Transport Canada as legislated under this Act. Almost without exception, the outfalls with quality for exemption under Section 5(2) of the Act. An application for exemption, however, must be submitted.

The covering letter, the application and the 10 copies of the plans are to be submitted to:

Transport Canada
Navigable Waters Protection Division
Room 820
Burrard Street
Vancouver, B.C.
V6Z 2J8
Tel: 604-775-8867

Construction must not proceed without the approval fo Transport Canada. This is usually issued within three months of initial application in a formal, registered document, which should be forwarded to the client Band with a copy to INAC’s District Office, or to the INAC District Office, c/o the applicable Project Officer and Lands Officer for the Band.

8. **Health Canada** for issues related to ground disposal of wastewater effluent to Federal Land especially from less than five house connections or flows less than 9,100 L/d from non-residential facilities.

Coastal District:

#510 – 1230 Government St.
Victoria, BC V8W 3Y2
Fax: 250-363-0179
Tel: 250-363-0249

Central District:

985 McGill Place
Kamloops, BC V2C 6X6
Fax: 250-851-4838
Tel: 250-851-4831

Northern District:

#220-177 Victoria St.
Prince George, BC V2L 5R8
Fax: 250-564-3272
Tel: 250-561-5378

APPENDIX VII

FIRST NATIONS WASTEWATER EMERGENCY RESPONSE PLAN GUIDE



Indian and Northern
Affairs Canada

Affaires indiennes
et du Nord Canada



FIRST NATIONS WASTEWATER Emergency Response Plan Guide

A handbook for First Nations Operators
and Band Administrators in British Columbia



FIRST NATIONS WASTEWATER Emergency Response Plan Guide

A handbook for First Nations Operators
and Band Administrators in British Columbia



ACKNOWLEDGEMENTS

Since the publishing of First Nations Drinking Water Emergency Response Plan Guide, we have been receiving inquiries about an emergency response plan guide for wastewater systems. It has been our intent to produce a user-friendly and informative document that First Nations in British Columbia can use in the development of a Wastewater Emergency Response Plan. I believe we have now achieved this goal.

Thanks to Jian (Jane) Guo, P.ENG., Professional and Technical Services, Indian and Northern Affairs Canada for dedicating time and special effort in preparing this guide. I would also like to thank Paula Santos, P.ENG., and Danny Higashitani, P.ENG., Professional and Technical Services, Indian and Northern Affairs Canada, for their valuable input.

Quality information and a well-designed Wastewater Emergency Response Plan are critical for a timely response to emergency situations. I hope this booklet will aid First Nations in this regard.

GARY GEE, P.ENG.

Director, Professional and Technical Services
Indian and Northern Affairs Canada BC Region



Table of Contents

1. Introduction 1
2. What is a sewage spill? 2
3. Why do you need a Wastewater Systems Emergency Response Plan? 2
4. What should your ERP include? 4
5. Communications 8
6. Examples of potential emergency situations and possible responses 10
7. Emergency Response Plan Action Lists 18

APPENDIX

- A. Wastewater Emergency Response Plan Contact List 20
- B. Emergency Response Activity Record and Reporting Template 21
- C. Wastewater/Receiving Water Sampling Instruction 24

1. Introduction

Raw or improperly treated sewage carries a dangerous cocktail of infectious bacteria, viruses, parasites and toxic chemicals. When it ends up in our drinking water, recreational water or in basements of our homes, it poses a significant threat to human health and the environment. Human contact with raw or improperly treated sewage can lead to serious health problems, including cholera, dysentery, infectious hepatitis, giardiasis, gastroenteritis, etc.. If released to fish-bearing waters, toxic substances in the raw sewage can also cause illness in fish and kill aquatic life.

Community sewage collection, treatment and disposal systems are designed to protect public health and the environment by conveying wastewater to treatment and disposal facilities prior to discharge. When these systems work as designed, there is little or no risk to public health or the environment. However, during emergencies, there can be increased risks. Preparing an emergency response plan (ERP) and practicing it can save lives, prevent illness, enhance system security, minimize property damage and environmental impact and lessen liability. An effective ERP includes planning for any and all possible emergency scenarios, communicating with system users and health and environmental authorities, and acting to stop, contain and minimize the effects of the spill.

The purpose of this guide/template is to assist BC First Nations administrators and wastewater systems operators to develop their own ERP to help them minimize the potentially damaging effects of sewage spills on public health and the environment. The guide/template provides examples of the most common types of emergencies with various levels and specific responses to those emergencies. It prompts operators to develop a list of people and agencies they may need to contact in case of emergency. The guide focuses on preventing or minimizing short-term and acute effects on public health and the environment associated with sewage spills. It is intended to supplement, rather than duplicate any existing ERPs.

2. What is a sewage spill?

A sewage spill means the release or discharge into the environment of raw sewage or improperly treated sewage effluent in an amount that can cause pollution. According to the BC *Spill Reporting Regulation*, the amount of sewage spill that can cause pollution is equal to or greater than 200 kg (or 200 L).

3. Why do you need a Wastewater Systems Emergency Response Plan?

As an operator of a community wastewater system, you need an ERP to ensure the safety and health of the people in your community and protection of the environment. The federal *Fisheries Act* prohibits the release of deleterious substances into fish bearing waters. The BC *Municipal Sewage Regulation* (MSR) enacted in 1999 prohibits the release of wastewater to the environment without meeting the effluent quality standards. The MSR also requires an operating plan including an emergency component be developed prior to effluent discharge.

A properly prepared, well thought out ERP will tell you exactly what to do and whom to call so that you can respond rapidly and effectively to any disruption to the downstream receptors. Your ability to respond rapidly and correctly in the event of a sewage spill will help prevent unnecessary problems and protect the health and safety of the community you are serving and the receiving environment within and around your community. It may also save you money by preventing further complications.



Action — not reaction

When a wastewater emergency situation does occur, you should immediately start taking the necessary actions to resolve it – not stand around wondering what you should do first or next. First, you have to be familiar with your community wastewater systems and be able to detect various types of potential problems and causes which could lead to spills. Then you have to determine solutions to each of those problems which could prevent spills before they occur or minimize the spills if they do occur. The act of preparing to respond to a wastewater emergency may actually help you prevent one from happening. By making a thorough evaluation of all the potential “trouble spots” or vulnerable points in your own system, you may identify steps you can take now that will prevent an emergency from happening later. Conditions which require public notification, requests for assistance and other possible concerns should all be identified in advance.

Following is some guidance on how to prepare an emergency response plan for your community wastewater system(s).

4. What should your ERP include?

Contact List

As a minimum, your ERP should include a list of contact people and phone numbers for trouble shooting, servicing and emergency assistance. This includes operators, repair people, government agencies, media representatives and community members. You should complete a Wastewater ERP Contact List as shown in Appendix A of this Guide and post it on the wall of your Band and operator's office. Your ERP should be organized into several logical sections so that information is easy to find. The following are some key elements that should be included in your ERP.

Part 1, Introduction

Describe the purpose, goals, roles and responsibilities of your Band and operator(s) of your wastewater systems, access control protocol and overall organization of the ERP.

Part 2, System Information

- Describe the sewage collection, treatment and disposal system as well as built-in redundancy features of the system;
- Outline measures in place to prevent emergency conditions from occurring;
- Describe equipment standard operating procedures,
- Describe procedures for connecting to portable pumps, switching to alternate power supplies and/or maintaining generators, including schematics of electrical systems in lift stations and wastewater treatment plants. They should be located beside the equipment they refer to.



- Provide a map of your community which shows the location of the items such as the ones below to help in the fastest possible response:
 - Wastewater collection lines
 - Critical control points (e.g., lift stations, shut-off valves, manholes, cleanouts, overflow storage or bypassing facilities)
 - Access routes, roads or trails to these critical control points
 - Wastewater treatment plant
 - Effluent disposal systems (i.e., ground disposal fields, outfalls, etc)
 - All built-in redundancy features of the facility
 - High volume sewage discharge businesses if any
 - Water distribution lines
 - Drinking water sources (wells, surface water intakes) and pump houses
 - Other high risk downstream receptors such as residents, schools, hospitals, daycare centres, long term care facilities, wells in unconfined aquifer or influenced by surface water, shellfish beds, recreational beaches, fish bearing waters
 - Storage location of tools and maintenance equipment
 - Storage location of your O & M Manual and O & M Plan
 - Location of your emergency contact list.

Part 3, Emergency Causes, Impact Levels and Responses

When preparing your ERP, you should try to identify all situations which could have a negative impact on human health/safety or the environment. Some of the causes of spills and other malfunctions you should identify include:

- Power failure
- Pump/siphon failure
- Electrical Control malfunctioning
- Broken sewer main.
- Blocked sewer main
- Malfunctioning of wastewater treatment plant
- Malfunctioning of wastewater disposal facilities (i.e. ground disposal fields, outfalls)
- Flooding of wastewater treatment or disposal facilities
- Snow/wind storm
- Fire
- Earthquakes damaging the system
- Act of vandalism causing system disruption



Impact caused by the above emergency situations is ranked into three levels, minor, significant and major emergencies. Examples of responding actions based on either causes or impact levels are illustrated in Section 6.

Part 4, ERP update and training

Describe the ERP review and update process, evaluate the effectiveness of the ERP and provide information on the wastewater system's ERP training program. You need to update relevant components of the ERP when new wastewater facilities are added or the existing system is altered. You must update your emergency contact list once per year or whenever your contact information changes whichever comes first. As an operator, you need to make yourself familiar with the emergency response plan when starting the job and when the ERP is updated. A one-hour wastewater emergency response drill is recommended once per year.

Appendices

Appendices should be utilized for supplementary material essential for the emergency response activities. It's imperative that you put together a telephone contact list, site and system drawings, record keeping forms/worksheets, checklists, pre-written press releases, incident specific action plans and other necessary documents.

5. Communications

Communications play a key role in how well you are able to respond during an emergency. Your particular communications plan depends more than anything else on the level of emergency situation. You must be able to alert all the receptors of the spill from your system as soon as possible, especially if there is a possible risk to their health from contacting the spilled sewage. Here are a few methods to illustrate how to get the message out to the community:

Public notices

A simple flyer/note to the affected people is an effective way to ensure that every person affected is aware of the current situation regarding the sewage spill. The key is to make sure that everyone gets the message that an emergency has occurred and that the area is no longer safe for normal use. Some possible suggestions for the flyer/note include:

- Use bright paper to ensure that it is visible, especially for older community members (and always use the same colour paper for a wastewater issue)
- Use readable, larger fonts so that the message can be read by everybody
- Post or tape the flyer to each house and don't simply place it in a mailbox or through the mail slot, where it has the chance to be missed
- Use the radio/telecommunication system if one is available in the community.

Phone trees

In the case of small or medium-sized communities, your communications plan may include organizing a “phone tree.” This is a pre-arranged plan which allows every household in the community

to be contacted with an important message by their neighbours, by telephone. People who have been phoned have their own list of other people to phone, who in turn have the names of others to phone, and so on down the line until everyone on the system has been alerted.

Many small communities already have some kind of “phone tree” system in place so they can respond quickly to other emergencies, such as alerting local volunteer fire fighters. Talk to your local fire chief, you may be able to use the same system for an emergency involving your wastewater system. If you use a phone tree, it is very important to keep it up to date.

For very small wastewater system where there is only one/two or a dozen connections, all located near each other, a “phone tree” probably isn’t necessary. In these cases, assuming that you as the wastewater operator are already at the scene, you can pass the word around just by knocking on a few doors, and getting others to pass the word around as well, so that all the users are made aware of the problem right away.

If you are using a “phone tree” to send out a message to your community members telling them not to use the sewer system (eg flushing toilets, doing laundry) during the spill, make sure that people who either don’t have phone lines or who aren’t in when the call is made also get the message.

Media

Local media – radio, television and newspapers – can also carry warnings to the community members if the situation is serious enough. Make sure you contact local media as part of your emergency planning to establish your credibility with them and to ensure that if you ever do have to call they will know who you are and how important it is to cooperate with you in alerting their readers or listeners.

6. Examples of potential emergency situations and possible responses

The following subsections describe some examples of potential emergency situations and possible responses. These are categorized as “responses based on causes”, which outline responses to common causes of emergencies in wastewater systems, and “responses based on levels of impact”, which outline responses to be taken depending on the consequences.

Please note, these examples may or may not apply to your particular wastewater system. The type of response, the contact list and the order of response will also vary with the size of your system, quantity, quality and location of spills, sensitivity of the receiving environment, and other factors.

If as a community wastewater systems operator, you believe the spill is not the responsibility of the Band, inform the resident of what to do and who to call for help. Provide a small works roster to the resident to use for contacting contractors.



6.1. Responses Based on Causes

Power outage

- ACTIONS**
- Notify the Chief and Council.
 - Call BC Hydro.
 - Start back-up generator.
 - Notify all users of interruption of service if back-up not capable of carrying away the flow.
 - Estimate the quantity of sewage spilled if any.
 - Determine the level of emergency.
 - Take further actions and make contact as per table on page 15 based on the level of emergency.

Pump/siphon failure

- ACTIONS**
- Notify the Chief and Council.
 - Call for repair service and/or equipment supplier.
 - Call circuit rider for advice if needed.
 - Replace with spare pump or hook up to a portable pump if available.
 - Notify all users of interruption service for minimizing washing and flushing activities.
 - Estimate the quantity of sewage spilled if any.
 - Determine the level of emergency
 - Take further actions and make contact as per table on page 15 based on the level of emergency.

Electrical Control malfunctioning

- ACTIONS**
- Notify the Chief and Council.
 - Call for repair service.
 - Call circuit rider for advice if needed.
 - Estimate the quantity of sewage spilled if any.
 - Determine the level of emergency
 - Take further actions and make contact as per table on page 15 based on the level of emergency.

Broken sewer main

- ACTIONS**
- Notify the Chief and Council.
 - Call for repair service.
 - Call circuit rider for advice if needed.
 - Contain the spill as much as possible.
 - Notify upstream sewer users for minimizing their washing and flushing activities until further notice.
 - Notify downstream spill receptors.
 - Arrange alternate sewage disposal if necessary, i.e. divert the spill into downstream manhole if possible, pump and haul, emergency storage, etc.
 - Estimate the quantity of sewage spilled if any.
 - Determine the level of emergency
 - Take further actions and make contact as per table on page 15 based on the level of emergency.

Malfunctioning wastewater treatment plant

- ACTIONS**
- Notify the Chief and Council.
 - Locate the parts that are malfunctioning if can.
 - Call for repair service or order replacement parts.
 - Call circuit rider for advice if needed.
 - Notify sewer users for minimizing washing and flushing activities until further notice.
 - Monitor the performance of the wastewater treatment plant.
 - Take effluent quality samples once per week while parts are malfunctioning.
 - Determine the impact of the malfunctioning and level of emergency.
 - Take further actions and make contact as per table on page 15 based on the level of emergency

Malfunctioning wastewater disposal facilities (ground disposal fields, outfalls)

- ACTIONS**
- Notify the Chief and Council.
 - Locate the areas that are malfunctioning if can.
 - Call for repair service or order replacement parts.
 - Call circuit rider for advice if needed.
 - Determine the impact of the malfunctioning and level of emergency.
 - Take further actions and make contact as per table on page 15 based on the level of emergency.



Flooding, Earthquake, Snow/windstorm, Fire, Act of vandalism

ACTIONS

- Notify the Chief and Council.
- Call fire fighters for fire, RCMP for vandalism.
- Advise all sewer users for minimizing their washing and flushing activities if sewer spill has occurred or is imminent.
- Take necessary actions outlined on page 15 when appropriate.
- Work together with Band Chief and Council and village maintenance personnel and water system operator for collaborated response.
- Contact media and phone trees for public notification.

6.2. Responses based on impact levels of emergency

Impact Levels	What it Means	Actions	Personnel/ Agency to Notify
Level 1 – Minor Emergency	<ul style="list-style-type: none"> • lower risk situation that requires minimal outside assistance, • there has been no spill or the spill size is less than 200L and there is no threat to drinking water or to a water body • the situation is not likely to cause public health or environmental problems, • the risks of personnel injury are relatively small, • this type of problem can normally be solved within 24 hours. 	<ul style="list-style-type: none"> • Call BC Hydro for power failure. • Call circuit rider for advice if needed. • Start back-up generator if power is out. • Arrange alternate sewage disposal if necessary, ie divert into downstream manhole if you can, pump and haul, emergency storage, etc. • Repair minor problems if you can. • Call for repair service and/or equipment supplier. • Notify downstream receptors. • Estimate the quantity of sewage spilled. • Advise upstream users to postpone and minimize their washing and flushing activities until further notice. • Record your emergency response activities (See Appendix B). • Record the time and duration of the spill. • Report to your circuit rider and INAC FSO. • Recover the damage after resuming to normal operation • Notify users. 	<ul style="list-style-type: none"> • Chief and Council • circuit rider • equipment supplier if necessary • INAC

Impact Levels	What it Means	Actions	Personnel/ Agency to Notify
Level 2 – Significant Emergency	<ul style="list-style-type: none"> the system experiences a significant spill or discharge (larger than 200 L) or major disruption that requires external coordination and/or issuance of a health advisory, the spill will be impacting drinking water or a water body, the risk of personnel injury and impact on public health or environment is elevated, will likely take more than 24 hours to resolve. 	<ul style="list-style-type: none"> All of Level 1 actions. Notify Provincial Emergency Program (PEP) if a spill larger than 200L has occurred to a water body. Take necessary steps to stop the spill and protect life, property and the environment. Isolate the sewer line, if possible, to stop, contain, or minimize the spill, or divert the spill to low risk areas. Identify spill receptors (ie downstream drinking water source, business or farming water users). Notify water system operators, business and farming water users immediately if they could be affected. Record the time and duration of the sewage spill. Record and report to INAC and PEP the incident including the following information (See Appendix B) Follow up with the affected receptors after emergency has been lifted. Secure the spill site to prevent contact by the public until the site has been thoroughly cleaned. Clean up the spill thoroughly after it is stopped. Where necessary, disinfect and /or deodorize the site using lime or other type of chemicals deemed appropriate. If spill is into a body of water that bears fish or other aquatic life, do not apply bleach or other disinfectant. Contact PEP for specific instructions. 	<ul style="list-style-type: none"> All of Level 1 contacts PEP if spill to the environment has occurred. All upstream sewer users for stopping or minimizing the discharge to sewers. All downstream property owners Downstream users of the effected areas Water system operators if source water is effected

Impact Levels	What it Means	Actions	Personnel/ Agency to Notify
Level 3 – Major Emergency	<ul style="list-style-type: none"> • Earthquake, massive flooding, storm or act of vandalism/terrorism causing massive disruption to the wastewater systems throughout the community. • immediate notification of local and other emergency management services is required to aid in efficient response actions, and of law enforcement if act of vandalism is suspected, • effective communication with communities is necessary to prevent injury or loss of life, • may take several days or weeks to resolve. 	<ul style="list-style-type: none"> • All of Levels 1 and 2 actions as appropriate. • Work together with the Band Chief and Council, Village maintenance personnel and water operator for collaborated response. • Contact media and phone trees for public notification. 	<ul style="list-style-type: none"> • All of Levels 1 and 2 contacts. • Local fire fighters • RCMP if emergency caused by vandalism, terrorism or sabotage.

7. Emergency Response Plan – Action Lists

TYPE OF EMERGENCY:

ACTIONS

- _____
- _____
- _____
- _____
- _____
- _____
- _____
- _____
- _____
- _____
- _____

CONTACTS

- 1 _____
- 2 _____
- 3 _____
- 4 _____
- 5 _____

TYPE OF EMERGENCY:

ACTIONS

- _____
- _____
- _____
- _____
- _____
- _____
- _____
- _____
- _____
- _____
- _____

CONTACTS

- 1 _____
- 2 _____
- 3 _____
- 4 _____
- 5 _____

TYPE OF EMERGENCY:

ACTIONS

- _____
- _____
- _____
- _____
- _____
- _____
- _____
- _____
- _____
- _____

CONTACTS

- 1 _____
- 2 _____
- 3 _____
- 4 _____
- 5 _____

TYPE OF EMERGENCY:

ACTIONS

- _____
- _____
- _____
- _____
- _____
- _____
- _____
- _____
- _____
- _____

CONTACTS

- 1 _____
- 2 _____
- 3 _____
- 4 _____
- 5 _____

APPENDIX

A. Wastewater Emergency Response Plan Contact List

	Organization	Name	Phone / Fax / Email
Band	Operator		
	Staff or 2nd operator		
	Chief		
	Band Administrator		
	Councillor		
	Circuit Rider		
Emergency Personnel	Police/Fire/Ambulance		
	Provincial Emergency Program (PEP)		1-800-663-3456
	RCMP		
Regulatory Authorities	INAC Funding Services Officer		
	Health Canada		
	Provincial Ministry of Environment Regional Office		
	Dept. of Fisheries & Ocean		
Utilities	Hydro		
	Gas		
	Telephone		
Media	TV		
	Radio		
	Newspaper		
Suppliers and Contractors	Nearest environmental lab 1		
	Nearest environmental lab 2		
	Pump rentals		
	Sewage pump/haul service		
	Pump system servicing		
	Pump supplier		
	Electrician		
	Excavation		
	Plumbing		
	General rental		
	Other		

Date this list completed _____

Name of person who completed list _____

Date for next updating (every 12 months recommended) _____

APPENDIX

B. Emergency Response Activity Record and Reporting Template

1. Date Checklist entered (yyyy/mm/dd): _____

2. Name of the person recorded: _____

3. Title of the person recorded:

WW System operator, Band Manager, Other (specify) _____

4. Description of cause(s) of the incident

Power Outage, area affected _____

Pump/siphon failure, Location _____

Electrical Control malfunctioning, Location _____

Broken sewer main, Location _____

Blocked sewer main, Location _____

Malfunctioning of wastewater treatment plant
Describe _____

Malfunctioning of wastewater disposal facilities (i.e. ground disposal fields, outfalls)

Flooding

Earthquake

Snow/wind storm

Fire

Act of vandalism, terrorism or sabotage (eg, explosions) causing massive system disruption.

Others, Specify _____

5. Effect of the incident observed:

6. Has any spill occurred? Yes No. If No, skip Sections 7 to 12.

7. Amount of spill estimated _____ Litre.

8. Location of the spill (Attach a copy of the site plan marked with the spill location).

9. Location of the affected downstream area:

- Drinking water source, specify location _____
- Well, specify location _____
- House or other buildings, specify location _____
- Fish bearing stream, specify location _____
- Swimming/recreational water body, specify location _____
- High traffic area, specify location _____
- Other, specify _____

10. Duration of spill:

From _____ Days _____ Hours To _____ Days _____ Hours

11. Type of spill:

- Raw sewage, Septic tank effluent, WW treatment plant effluent

12. Samples taken:

Location 1 (attach a site plan),

Date (yyyy/mm/dd): _____, Time: _____ Hour,
CBOD₅ _____ mg/L, TSS _____ mg/L,
Fecal Coliform _____ MPN/100 mL, LC50* _____

Location 2 (attach a site plan),

Date (yyyy/mm/dd): _____, Time: _____ Hour,
CBOD₅ _____ mg/L, TSS _____ mg/L,
Fecal Coliform _____ MPN/100 mL, LC50* _____

Location 3 (attach a site plan),

Date (yyyy/mm/dd): _____, Time: _____ Hour,
CBOD₅ _____ mg/L, TSS _____ mg/L,
Fecal Coliform _____ MPN/100 mL, LC50* _____

Location 4 (attach a site plan),

Date (yyyy/mm/dd): _____, Time: _____ Hour,
CBOD₅ _____ mg/L, TSS _____ mg/L,
Fecal Coliform _____ MPN/100 mL, LC50* _____

(*Sampling for fish bioassay LC50 is required only if spill leads to a fish bearing water body)

13. Level of Impact (See Section 6.2 for ranking criteria):

- Level 1 – Minor, Level 2 – Significant, Level 3 – Major

14. Other actions taken:

15. Persons Contacted:

Date _____, Name _____, Telephone No. _____

Date _____, Name _____, Telephone No. _____

Date _____, Name _____, Telephone No. _____

Date _____, Name _____, Telephone No. _____

Date _____, Name _____, Telephone No. _____

Date _____, Name _____, Telephone No. _____

Date _____, Name _____, Telephone No. _____

Date _____, Name _____, Telephone No. _____

16. Person/agencies on the scene

Date _____, Name _____, Agency. _____

Date _____, Name _____, Agency. _____

Date _____, Name _____, Agency. _____

Date _____, Name _____, Agency. _____

17. Further actions to be taken and when:

- Action 1 _____,
By Date (yyyy/mm/dd) _____
- Action 2 _____,
By Date (yyyy/mm/dd) _____
- Action 3 _____,
By Date (yyyy/mm/dd) _____

APPENDIX

C. Wastewater/Receiving Water Sampling Instruction

Sampling for CBOD5 and TSS:

Use a 1 L clean plastic bottle, fill the sample completely to the top, squeeze out any air bubbles and cap tightly. Samples must be stored in a cooler with an ice pack and delivered to the lab as soon as possible. The maximum storage time before measurement is 48 hours.

Sampling for Fecal Coliform:

Use a 500 mL plastic sterilized bottle (preferably sent from the lab that you will be using). Samples must be stored in a cooler with an ice pack and delivered to the lab as soon as possible. The maximum storage time before measurement is 24 hours.

Sampling for Fish Bioassay LC50 96 hours:

Use 2 x 20 L plastic containers unpreserved. Plastic collapsible drinking water containers or clean fuel jerrycans can be used. Containers should be purchased new and rinsed out at least twice with the sample before filling (to rinse out manufacturing residues). There is no need to store the sample in a cooler. In fact, you should not allow the samples to freeze. The maximum holding time before measurement is 72 hours (3 days).



CHECKLIST

FOR WASTEWATER EMERGENCY RESPONSE PLAN PREPARATION

1. Emergency Phone Contact List, including

- Personnel
- Circuit Rider(s)
- Government agencies
- Repair Services
- Tribal Council

2. Emergency Procedures

- Possible emergency situations
- Power failure
- Pump/siphon failure
- Electrical control malfunctioning
- Broken sewer main
- Blocked sewer main
- Malfunctioning of wastewater treatment plant
- Malfunctioning of wastewater disposal facilities
- Flooding
- Snow/wind storm
- Fire
- Earthquake
- Vandalism
- Levels of impact
- Response Plan (for each emergency)
- Personnel assignments and responsibilities

3. Map of System, showing

- Sewer mains
- Critical control points
- Access routes
- Wastewater treatment plant(s)
- Effluent disposal systems
- All build-in redundancy features of the wastewater facility
- High volume sewage discharge businesses (if any)
- Water distribution lines
- Drinking water sources
- Other high risk downstream receptors (shellfish beds, swimming beaches, residents, etc.)
- Storage location of tools and maintenance equipment
- Storage location of O & M Manual and O & M Plan
- Location of your emergency contact list

4. Electrical Schematics

- Generators
- Portable pumps
- Communication systems

5. General Procedures

- Generator start-up
- Power source change over
- Workplace hazards information system
- Occupational safety and health procedures

APPENDIX VIII
CHECKLIST FOR FEASIBILITY REPORT

Checklist for Feasibility Report

- 1) Project Description
 Included in Section _____; N/A; Notes: _____.
- 2) Project Rationale
 Included in Section _____; N/A; Notes: _____.
- 3) Project Terms of Reference
 Included in Section _____; N/A; Notes: _____.
- 4) Existing Facilities Summary
 Included in Section _____; N/A; Notes: _____.
- 5) Wastewater and Sludge Quantity and Quality
 Included in Section _____; N/A; Notes: _____.
- 6) Option Analysis
 Included in Section _____; N/A; Notes: _____.
- 7) Preferred Option Recommended
 Included in Section _____; N/A; Notes: _____.
- 8) Land Requirements Identified
 Included in Section _____; N/A; Notes: _____.
- 9) O&M Capacity Assessment
 Included in Section _____; N/A; Notes: _____.
- 10) Sub-consultant Reports
 Included in Section _____; N/A; Notes: _____.
- 11) Environmental Assessment Scoping Report
 Included in Section _____; N/A; Notes: _____.
- 12) Regulatory Impacts/Permits Identified
 Included in Section _____; N/A; Notes: _____.
- 13) Land Encumbrance Check
 Included in Section _____; N/A; Notes: _____.
- 14) Project Schedule
 Included in Section _____; N/A; Notes: _____.
- 15) Project Construction (or procurement) Process
 Included in Section _____; N/A; Notes: _____.

- 16) Class 'C' Capital Cost Estimate (Class 'D' acceptable for Phase 1 in a two-phase feasibility study)
 Included in Section _____; N/A; Notes: _____.
- 17) Class 'C' O&M and Lifecycle Cost Estimate (Class 'D' acceptable for Phase 1 in a two-phase feasibility study)
 Included in Section _____; N/A; Notes: _____.
- 18) Pre-design or Phase 2 (as appropriate) Additional Research Identified
 Included in Section _____; N/A; Notes: _____.
- 19) Handling of power failure and emergency overflows
 Included in Section _____; N/A; Notes: _____.
- 20) Equipment and process reliability Category (MSR)
 Included in Section _____; N/A; Notes: _____.

APPENDIX IX
CHECKLIST FOR PRE-DESIGN REPORT

Checklist for Pre-design Report

- 1) Updated Project Description and Project Rationale
 Included in Section _____; N/A; Notes: _____.
- 2) Existing Conditions and Projections
 Included in Section _____; N/A; Notes: _____.
- 3) Existing Facilities Evaluation
 Included in Section _____; N/A; Notes: _____.
- 4) Preliminary Design Criteria
 Included in Section _____; N/A; Notes: _____.
- 5) Preliminary Design Investigations
 Included in Section _____; N/A; Notes: _____.
- 6) Proposed Project Development
 Included in Section _____; N/A; Notes: _____.
- 7) Capital Cost Estimate
 Included in Section _____; N/A; Notes: _____.
- 8) O&M Cost Estimate
 Included in Section _____; N/A; Notes: _____.
- 9) 20-year Lifecycle Cost Estimate
 Included in Section _____; N/A; Notes: _____.
- 10) Regulatory and Permitting Requirements
 Included in Section _____; N/A; Notes: _____.
- 11) Legal Considerations
 Included in Section _____; N/A; Notes: _____.
- 12) Comments from Regulatory Agencies
 Included in Section _____; N/A; Notes: _____.
- 13) Land Encumbrance Confirmation
 Included in Section _____; N/A; Notes: _____.
- 14) Process Diagrams and Hydraulic Profile
 Included in Section _____; N/A; Notes: _____.
- 15) Maps, photos, diagrams, sketches
 Included in Section _____; N/A; Notes: _____.

- 16) O&M Considerations
 Included in Section _____; N/A; Notes: _____.
- 17) Wastewater disposal methods and requirements
 Included in Section _____; N/A; Notes: _____.
- 18) Probable Facility Classification
 Included in Section _____; N/A; Notes: _____.
- 19) Candidate Operators Identification
 Included in Section _____; N/A; Notes: _____.
- 20) Operator Training Plan
 Included in Section _____; N/A; Notes: _____.
- 21) Environmental Assessment Report
 Included in Section _____; N/A; Notes: _____.

APPENDIX X

CHECKLIST FOR DESIGN BRIEF AND FINAL DESIGN DRAWINGS

Checklist for Design Brief and Final Design Drawings

Design Brief

- 1) Updated Project Description and Project Rationale
 Included in Section _____; N/A; Notes: _____.
- 2) Design Criteria
 Included in Section _____; N/A; Notes: _____.
- 3) Collection System
 Included in Section _____; N/A; Notes: _____.
- 4) Treatment System
 Included in Section _____; N/A; Notes: _____.
- 5) Disposal/Reuse
 Included in Section _____; N/A; Notes: _____.
- 6) Class 'A' Cost Estimates
 Included in Section _____; N/A; Notes: _____.
- 7) Draft O & M Documents (see checklist Appendix XI)
 Included in Section _____; N/A; Notes: _____.
- 8) Commissioning Plan
 Included in Section _____; N/A; Notes: _____.
- 9) Performance Monitoring Plan
 Included in Section _____; N/A; Notes: _____.
- 10) Final Environmental Assessment Report (if not completed in pre-design stage)
 Included in Section _____; N/A; Notes: _____.
- 11) Operator Training Plan
 Included in Section _____; N/A; Notes: _____.
- 12) Facility Classification
 Included in Section _____; N/A; Notes: _____.
- 13) Confined Space Entry Minimization/Elimination
 Included in Section _____; N/A; Notes: _____.

Final Design Drawings

- 1) Location Plan
 Included in Section _____; N/A; Notes: _____.

- 2) General Layout
 Included in Section _____; N/A; Notes: _____.
- 3) Plan and Profile Drawings of Collection System
 Included in Section _____; N/A; Notes: _____.
- 4) Collection System Details
 Included in Section _____; N/A; Notes: _____.
- 5) Wastewater Pumping Stations
 Included in Section _____; N/A; Notes: _____.
- 6) Wastewater Treatment Facilities
 Included in Section _____; N/A; Notes: _____.
- 7) Disposal Facilities
 Included in Section _____; N/A; Notes: _____.

APPENDIX XI

**OPERATION AND MAINTENANCE MANUAL AND OPERATION AND MAINTENANCE
PLAN FOR WASTEWATER SYSTEMS – CHECKLIST**

**Operation and Maintenance Manual and
Operation and Maintenance Plan
For Wastewater Systems**

Checklist

Operation and Maintenance Manual

1. System Description
 - 1.1. Overview (description, location plan and simplified schematic plan or flow chart)
 Included in Section _____; N/A; Notes: _____.
 - 1.2. Confined Spaces (A list of confined spaces, hazard assessment and entry procedures acceptable to the applicable health and safety regulatory agencies)
 Included in Section _____; N/A; Notes: _____.
 - 1.3. Collection System (gravity sewer, forcemains, pumping stations, etc.)
 Included in Section _____; N/A; Notes: _____.
 - 1.4. Treatment (designed flow capacity, designed serving population, treatment description, designed effluent quality, process flow chart)
 Included in Section _____; N/A; Notes: _____.
 - 1.5. Effluent Disposal (location of receiving environment, GPS of point of discharge, method of discharge, etc)
 Included in Section _____; N/A; Notes: _____.
 - 1.6. Solids (estimated quantity, type of solids, solids content, frequency of discharge, discharge location)
 Included in Section _____; N/A; Notes: _____.
 - 1.7. Effluent sludge discharge permits
 Included in Section _____; N/A; Notes: _____.
2. Operation and Maintenance
 - 2.1. Start-up, shut-down, operation and maintenance procedures (incl. system monitoring, control and alarms, list of equipment, servicing schedule)
 - 2.1.1. Collection
 Included in Section _____; N/A; Notes: _____.
 - 2.1.2. Treatment
 Included in Section _____; N/A; Notes: _____.
 - 2.1.3. Disposal
 Included in Section _____; N/A; Notes: _____.
 - 2.2. Trouble shooting (incl. contacts for Circuit Riders / INAC CAIS staff, suppliers, service contractors, etc.)
 Included in Section _____; N/A; Notes: _____.
 - 2.3. Health & Safety (wastewater and chemical handling, confined space entry, use of safety equipment and protective gears, etc.)

- Included in Section _____; N/A; Notes: _____.
- 2.4. Flow recording, wastewater sample and testing (specify sampling sites on as-built drawings, parameters, frequency, instruction)
 Included in Section _____; N/A; Notes: _____.
- 2.5. Receiving environment monitoring program if required
 Included in Section _____; N/A; Notes: _____.
- 2.6. Inspection (list of equipment, inspection procedures)
 Included in Section _____; N/A; Notes: _____.
- 2.7. A list of tools, spare equipment and parts for routine or emergency maintenance repairs and storage location
 Included in Section _____; N/A; Notes: _____.
- 2.8. Maintenance, sampling and inspection checklist and data log template
 Included in Section _____; N/A; Notes: _____.
3. Facility Classification and Required Operator Certification Level
 Included in Section _____; N/A; Notes: _____.
4. Capital Asset Inventory List
 Included in Section _____; N/A; Notes: _____.
5. Manufacturer/Contractor literature
- 5.1. Material and equipment information (names, model numbers, types, sizes, certifications, warranties)
 Included in Section _____; N/A; Notes: _____.
- 5.2. Instructions and schedules for O & M
 Included in Section _____; N/A; Notes: _____.
- 5.3. Manufacturer equipment, O&M manuals, commissioning procedures, signed warranty certificates, and all equipment and instrumentation set-up parameter lists.
 Included in Section _____; N/A; Notes: _____.
- 5.4. Exploded views and parts lists
 Included in Section _____; N/A; Notes: _____.
- 5.5. Shop drawings
 Included in Section _____; N/A; Notes: _____.
- 5.6. Suppliers' names, addresses and phone numbers
 Included in Section _____; N/A; Notes: _____.
- 5.7. Contacts for authorized service agents
 Included in Section _____; N/A; Notes: _____.
6. Control System Documentation
 Included in Section _____; N/A; Notes: _____.

7. As-built drawings
 Included in Section _____; N/A; Notes: _____.

8. Site construction photographs or sketches which supplement or simplify the explanation of various O&M procedures
 Included in Section _____; N/A; Notes: _____.

Operation and Maintenance Plan (see sample template next page)

1. Task statements/Work orders
 Included in Section _____; N/A; Notes: _____.

2. Annual Work Plan
 Included in Section _____; N/A; Notes: _____.

3. Annual O & M cost estimate
3.1. Required labour hours for each task and wages
 Included in Section _____; N/A; Notes: _____.

3.2. Estimated cost for service contracts if any
 Included in Section _____; N/A; Notes: _____.

3.3. Estimated utility cost (heat/fuel, electricity)
 Included in Section _____; N/A; Notes: _____.

3.4. Estimated cost for equipment fixing/replacement, chemicals, etc.
 Included in Section _____; N/A; Notes: _____.

4. Reporting Template
4.1. Annual inspection report
 Included in Section _____; N/A; Notes: _____.

4.2. O & M, flow and wastewater quality data log
 Included in Section _____; N/A; Notes: _____.

4.3. Operators' name, training and certification information
 Included in Section _____; N/A; Notes: _____.

4.4. Expenditures
4.4.1. Wages
 Included in Section _____; N/A; Notes: _____.

4.4.2. Service contracts
 Included in Section _____; N/A; Notes: _____.

4.4.3. Utility (heat/fuel, electricity)
 Included in Section _____; N/A; Notes: _____.

4.4.4. Equipment fixing/replacement, chemicals
 Included in Section _____; N/A; Notes: _____.

4.4.5. Other

TEMPLATE FOR WORK ORDER

WORK ORDER OR TASK CODE

ORGANIZATION:

ACTIVITY:

ASSET:

LOCATION:

QUANTITY:

TASK FREQUENCY:

WORK CREW:

TIME REQUIRED:

EQUIPMENT REQUIRED:

MATERIALS REQUIRED:

CONTRACTED SERVICES REQUIRED:

SAMPLE TASK DESCRIPTION

- 1) Record totalizer data to determine wastewater flow. Calculate total flow in cubic meters (5.38 x total doses).
- 2) Remove lids from the screen chamber. Observe the surface for signs of floating particles or grease, which would mean the household septic tanks require pump out.
- 3) Remove each filter assembly and rinse clean, then replace into the chamber supports.
- 4) Remove lid from each dosing tank. Check if either tank level is at overflow. If at overflow, the tank would need to be pumped and rinsed, and then siphon would need to be unplugged by a confined space contractor.

APPENDIX XII

**TERMS OF REFERENCE FOR PERFORMANCE MONITORING PLAN FOR
WASTEWATER TREATMENT FACILITIES**

TERMS OF REFERENCE FOR PERFORMANCE MONITORING PLAN FOR WASTEWATER TREATMENT FACILITIES

1.0) OBJECTIVES

- To have the design engineer provide advice during the first year of operation in order to optimize operation and solve start-up problems.
- To obtain a performance report which provides data and analyses for a one year monitoring period that verifies the design objectives and demonstrates the performance of the facility.

2.0) SCOPE OF WORK

The scope of work includes the following items:

- 1) Use the installed monitoring equipment to provide data regarding flow rates, water demand and other operating conditions.
- 2) Organize and implement a sampling and analysis program to measure the quality of untreated influent wastewater and treatment effluent. Sufficient independent laboratory tests should be included to confirm the field results. Parameters to be monitored should be based on the Environmental Assessment Study Report (See Section 1.3.9.7 of the *INAC Design Guidelines for Wastewater Systems, BC Region, 3rd Edition*).
- 3) Prepare record forms and train the operator(s) on use of instruments and collection of wastewater samples.
- 4) Utilize the Operation and Maintenance Documents as an instruction tool during the plant performance monitoring period. Record any operations and maintenance problems and modify the Operation and Maintenance Manual accordingly. Provide advice to the Band regarding any modifications to the operations or the facility which would make the operation easier and more efficient. Ensure that the Operation and Maintenance Manual will assist the operator(s) in the preparation of ongoing performance monitoring and reporting. Prepare an Operation and Maintenance budget for subsequent years based on the actual materials and labour for the one-year of operations and considering the optimized plant performance.
- 5) Assist the Band in obtaining training on the operation and maintenance of the facility. Use of certified operators from other First Nation facilities is encouraged if not locally available.
- 6) Evaluate, and compare to the design objectives, the performance of all components of the facility. Carefully document the performance of each wastewater treatment unit process, including all relevant parameters such as flow rates, daily operator time, power demands, etc. Record the operation of any pumping systems.

7) After the end of the one year monitoring period, prepare a comprehensive performance monitoring report, including log sheets, graphs, analysis, etc.

3.0) TERMS OF PAYMENT

Payment will be made on a time rate fee plus disbursements basis. Disbursements will be charged on an actual cost basis.

The Qualified Professional will, on a monthly basis (or other approved interval), submit an invoice detailing the services performed.

No payment will be made on the cost of work incurred to remedy errors or omissions for which the Qualified Professional is responsible.

4.0) COST CONTROL

If at any time during the progress of the work, the Qualified Professional considers that the cost figure outlined in the contract will be exceeded, either by some unforeseen event or work outside the Terms of Reference, he shall IMMEDIATELY provide the Project Manager with complete details.

5.0) PROJECT MANAGEMENT

The Project Manager will be a designated representative of the Band.

6.0) SCHEDULE

The work will start as soon as possible after agreement to proceed. The special performance monitoring period will be for one year and the performance report should be submitted within one month after the end of the one year.

7.0) SITE VISITS

All site visits require prior agreement by the appropriate First Nation Officials.

APPENDIX XIII
DEFINITION AND ABBREVIATIONS

APPENDIX XIII

DEFINITION AND ABBREVIATIONS

1. DEFINITION

Average Dry Weather Flow (ADWF)	Wastewater flow measured during period of no rainfall. Rates of flow exhibit typical hourly and daily variations. Infiltration is assumed present, but is generally low due to a low water table in dry weather.
Average Wet Weather Flow (AWWF)	Wastewater flow following periods prolonged of rainfall. Storm water inflow and infiltration may increase the wet weather flow to rates many times larger than the dry weather flow, and unless capacity is available in the collectors and treatment facilities, hydraulic overloads may cause sewerage backups and overflows to public streets or watercourses.
Benthic Invertebrate Communities	Benthic invertebrates are organisms that live on the bottom of a water body (or in the sediment) and have no backbone. Benthic invertebrate communities can be either on the surface of bedforms (e.g. rock, coral, or sediment – epibenthos) or within sedimentary deposits (infauna), and comprise several types of feeding groups, e.g. deposit-feeders, filter-feeders, grazers and predators.
5-day Biochemical Oxygen Demand	A measure of oxygen consuming property of the wastewater expressed in terms of oxygen that is consumed biologically. It is a measure of wastewater strength that represents the amount of oxygen consumed in 5 days at 20 °C.
Biosolids	Treated wastewater sludge.
Carbonaceous Biochemical Oxygen Demand	The amount of Biochemical Oxygen Demand for the oxidation of carbon-based organic wastes only. Biochemical oxygen requirements for conversion of ammonia to nitrates are not included.
Chlorine Residual	The amount of chlorine left after a given contact time in wastewater which remains available for further bacteriological kill. It is the difference between the chlorine dosage and the chlorine demand. The chlorine demand is the chlorine concentration needed to oxidize the chemical, bacteriological, and other species in the wastewater.

Collective System	A wastewater system servicing five or more houses or having the flow capacity of equal to or larger than 9,100 L/day from non-residential facilities.
Commercial Wastewater	Wastewater generated in areas predominantly commercial in business nature, includes sanitary wastes and wastes resulting from the activities of the business itself. Typically, commercial wastewater may include wastewaters from laundromats, restaurants, car washes, and garbage.
Completion of Construction	Declaration that all works are complete, including deficiencies.
Consultant	A professional who provides advice in a particular area of expertise (i.e., engineering)
Domestic Wastewater	Wastewater principally derived from residential source or produced by normal residential activities.
Effluent	Liquid flowing out of a wastewater treatment facility after completing the treatment.
Equivalent Residential Population	Wastewater flow and load contributed by Industrial, Commercial and Institutional sector converted to equivalent number of residents.
Individual System	A wastewater system servicing less than five house connections or having a flow less than 9,100 L/day from non-residential facilities.
Industrial Wastewater	Wastewater from manufacturing and industrial processes distinct from domestic or commercial wastewater.
Inflow	Rain which enters the wastewater collection system through direct connections or available openings in the sewer system. Entry may originate from illegal storm connections, manhole lid submergences or catch basin connections. Direct storm inflow is distinct from infiltration and is observed as a peak flow during a rainstorm. In contrast, infiltration would be observed as an extended period of inflow.
Infiltration	Groundwater movement into the wastewater collection system for faulty construction, disrepair or defective materials. High groundwater tables or saturation of the soil from rains or irrigation waters may add to the infiltration in a wastewater collection system.

Initial Dilution Zone	If effluent is discharged into a water body, the initial dilution zone is the 3 dimensional zone around the point of discharge where mixing of the effluent and the receiving water occurs.
LC50 Bioassay	The concentration of a pollutant in test waters that is lethal to 50 of the test organisms during continuous exposure for a specified period of time (96 hours).
Liquid Waste	Liquid waste includes sanitary sewerage and storm water effluent both from urban and agricultural run-off. Minimizing the impacts of water pollution from point sources such as wastewater treatment plants, and non-point sources such as urban run-off and storm water overflows is dependent upon waste treatment and reduction technologies as well as land use patterns. Most local governments have adequate means to address storm water through conventional mechanisms; however, greater emphasis is now being placed on a broader management of storm water, including infiltration. The RGS supports and encourages the use of innovative approaches and technologies to manage liquid water in an environmentally and economically sustainable manner.
Maximum Month Flow (MMF)	The maximum wastewater flow measured during any 30 consecutive days.
Peak Wet Weather Flow (PWWF)	Wet weather flow during an instantaneous peak sanitary wastewater flow. The peak wet weather flow is derived by adding the I&I to a peaked sanitary flow, or by adding infiltration to a peaked ADWF. This study uses the peaked sanitary flow added to I&I.
Peaking Factor	A factor to describe the peak instantaneous or maximum hourly wastewater flow either as sanitary or ADWF. The peaking factor is a function of the number of contributors, or tributary area size.
pH	A measure of acidity and alkalinity of a solution that is a number on a scale on which a value of 7 represents neutrality and lower numbers indicate increasing acidity and higher numbers increasing alkalinity.
Qualified Professional	A professional who is certified to practice in BC appropriate professional organization, acting under that association's Code of Ethics and subject to disciplinary action by that association. For the study and design of wastewater systems, the Qualified Professional shall be a Professional Engineer registered with the Association of Professional Engineering and Geoscientists

of BC in the wastewater engineering/civil engineering discipline.

Sanitary Flow	Domestic, commercial and industrial wastewater at the point of source and not including extraneous infiltration or inflow amounts.
Septage	The accumulated sludge in septic tanks, wastewater collection systems, etc.
Supernatant	The usually clear liquid overlying material deposited by settling, precipitation, or centrifugation.
Total Suspended Solids	The suspended matter transported in wastewater. Total suspended solids (TSS) and Carbonaceous Biochemical Oxygen Demand (CBOD5) are two basic criteria used to grade the strength of wastewater and the quality of effluent. The quantity of suspended material removed during treatment is dependent on the type and extent of treatment used and has an important bearing on sizing of treatment components.
Volatile Solids	Those solids in water or other liquids that are lost on ignition of the dry solids at 550 degrees C.
Waste Solids	Solid or semisolid wastes generated in the wastewater system, including grit, screenings, sludge, scum, biosolids, etc.
Wastewater	A combination of water carried wastes originating from residential, commercial, institutional and industrial sources, together with any groundwater, surfaces and storm waters which may be present.

2. ABBREVIATIONS

AAF	Average (daily) annual flow
AASHTO	American Association of State Highway and Transportation Officials, H-10 Standard (Light Truck Access and Parking)
ADWF	Average dry weather flow
ALR	Agricultural Land Reserve
ANSI	American National Standards Institute
APHA	American Public Health Association
AWWA	American Water Works Association
ASCE	American Society of Civil Engineers
ASTM	American Society of Testing Materials
BCWWA	B.C. Water and Wastewater Association

BOD ₅	Total 5 day Biochemical Oxygen Demand, mg/L.
CBOD ₅	5 day carbon Biochemical Oxygen Demand, mg/L (carbonaceous demand only, does not include nitrogenous demand)
CCME	Canadian Council of Ministers of the Environment
CEPA	Canadian Environmental Protection Act
COD	Chemical oxygen demand, mg/L
CSA	Canadian Standard Association
DWF	Dry weather flow (average day)
DWI	Dry weather inflow
EC	Environment Canada
EEMAC	Electrical Equipment Manufacturers Association of Canada
EIS	Environmental impact study
ha	Hectares
HRT	Hydraulic retention time
ICI	Industrial, commercial and institutional
IDZ	Initial dilution zone
INAC	Indian and Northern Affairs Canada
kW	Kilowatt
L/c/d	Litres per capita per day
L/s	Litres per second
LAH	Level alarm - high
LAL	Level alarm - low
LAN	Local area network, computer surveillance, recording and control at the plant.
LE	Level element (sonar)
m ³ /d	cubic metres per day
MLSS	Mixed liquor suspended solids
MLVSS	Mixed liquor volatile suspended solids
MMCD	Master Municipal Construction Documents
MOE	Ministry of Environment
MOH	Ministry of Health
MPN	Most probable number
MSR	Municipal Sewage Regulation
MTSA	Municipal Type Service Agreement
NH ₃ -N	Ammonia nitrogen
NH ₄	Total ammonia as nitrogen, mg/L
NMCS	Canadian National Master Construction Specification
NO _x	Total nitrates and nitrites as nitrogen
NTU	Nephelometric turbidity units
O&M	Operation and maintenance
OMRR	Organic matter recycling regulation
PLC	Programmable logic controller

PWWF	Peak (hour) wet weather flow
QA/QC	Quality assurance/quality control
RBS	Return biological sludge
SBR	Sequencing batch reactor
SCADA	Supervisory control and data acquisition
SRT	Solids retention time
STP	Sewage treatment plant
TKN	Total Kjeldahl nitrogen as nitrogen, mg/L
TP	Total phosphorous
TRC	Total residual chlorine
TSS	Total suspended solids, mg/L
USEPA	U.S. Environmental Protection Agency
UV	Ultraviolet
WPCF	Water pollution control federation

APPENDIX XIV

REFERENCES

REFERENCES

Revisions to these Guidelines were based on team experience as well as the following references:

- “Design Manual Municipal Wastewater Stabilization Ponds” by the U.S. Environmental Protection Agency, EPA-625/1-83-015, October 1983
- “High Performance Lagoon Systems” by Linvil G. Rich, American Academy of Environmental Engineers, 1999
- “Wastewater Engineering Treatment and Reuse” by Metcalf & Eddy, McGraw-Hill, 2003
- “Design of Municipal Wastewater Treatment Plants WEF Manual of Practice 8” by the Water Environment Federation, fourth edition, 1998
- “Small and Decentralized Wastewater Management Systems” by Crites and Tchobanoglous, McGraw-Hill, 1998
- “Onsite Wastewater Treatment Systems Manual” by the U.S. Environmental Protection Agency (EPA/625/R-00/008, February, 2002);
- “Municipal Sewage Regulation” by the BC Ministry of Environment, April, 1999;
- “Sewerage System Standard Practice Manual” by the B.C. Ministry of Health Services, June 7, 2005;
- “Organic Matter Recycling Regulation” by the BC Ministry of Environment, February, 2002;
- “CAN/CSA Standard B66-00 Prefabricated Septic Tanks and Sewage Holding Tanks” a National Standard of Canada, approved March 2002.
- “Large On-Site Sewage System Regulations” State of Washington Administrative Code, Last Update 11/5/03
- “Alberta Private Sewage Systems Standard of Practice 1999 Handbook” Plumbing Technical Council task Group
- “Hydraulic Loading Rates for Type 1, Type 2, and Type 3 Effluent Supporting Documentation,” by Derek Smith, B.Sc., R.E.H.O, for B.C. Ministry of Health, March 29, 2000.